



## LTS1321 1x9 155 Mb/s SM Optical Transceiver ATM, FDDI, Fast Ethernet, OC-3, 1310 nm, 2 km, 5.0 V

The LTS1321 single-mode duplex optical transceiver is designed for 2 km reach applications in 100 Mb/s high speed LAN/SAN (Fast Ethernet), 100 Mb/s ATM, 125 Mb/s FDDI, 155 Mb/s SONET OC-3 and 155 Mb/s SDH STM-1 optical communications equipment where low-cost, low power consumption, extraordinary performance and reliability are essential. It is housed in a compact MSA compliant 1x9 SIL plastic package with integral SC duplex optical receptacle and is designed to operate from either a nominal 3.3 volt or 5.0 volt power source over the commercial temperature range of 0 to 70 degrees Centigrade (-40 to +85 degrees Centigrade is available upon request). The differential transmitter and receiver I/O signal interfaces are DC-coupled PECL. The signal detect monitor function is DC-coupled PECL.



Duplex SC 1x9 Transceiver

### Applications

- 100 Mb/s ATM
- 100Mb/s 100 BASE -FX Fast Ethernet
- 125 Mb/s ANSI X3.184-1993 FDDI
- 155 Mb/s Telcordia SONET OC-3
- 155 Mb/s ITU-T G.957 SDH STM-1/ I-1
- Back to Back system interconnects
- Wiring closet interconnect
- Media Converters
- Hub interconnects
- Bus extenders
- Channel extenders
- Host adapter interconnects
- Mass storage system interconnects
- Router interconnects

### Features

- 1x9 MSA compliant SIL package
- SC Duplex optical interface
- Single Mode operation
- 2 km reach
- Power Supply Options
  - 3.3 Volts
  - 5.0 Volts
- Low DC power consumption
- High performance 1310 nm F-P laser
- High sensitivity PIN/TIA optical receiver:
- BER < 1x10<sup>-10</sup> (2<sup>23</sup> - 1 NRZ PRBS test pattern)
- Operating temperature range:
  - Commercial: 0 to 70°C (Standard)
  - Industrial: -40 to 85°C (Upon Request)
- Tx DATA
  - Differential PECL - 5.0 V Model
  - Differential LVPECL - 3.3 V Model
  - DC coupled
- Rx DATA
  - Differential PECL - 5.0 V Model
  - Differential LVPECL - 3.3 V Model
  - DC coupled
- Rx\_SD (Signal Detect)
  - Single Ended PECL - 5.0 V Model
  - Single Ended LVPECL - 3.3 V Model
  - DC coupled

### HOW TO ORDER (SUFFIX CODES WXYZ)

Part Number	Package Type (W)		Operating Voltage (X)		Rx_SD Option (Y)		Temperature Option (Z)	
LTS1321 S3LC	S	SC Receptacle	3	3.3 V	L	LVPECL	C	0 to 70 °C
LTS1321 S5PC	S	SC Receptacle	5	5.0 V	P	PECL	C	0 to 70 °C



## LTS1321 1x9 155 Mb/s SM Optical Transceiver

### ATM, FDDI, Fast Ethernet, OC-3, 1310 nm, 2 km, 5.0 V

Absolute Maximum Ratings						
Parameter	Symbol	Min	Max	Units	Notes	
Storage Temperature	$T_{stg}$	-40	85	°C		
Operating Temperature	$T_{amb}$	0	70	°C	Temp Option "C"	
Operating Temperature	$T_{amb}$	-40	85	°C	Temp Option "H"	
Relative Humidity - Storage	$RH_S$	0	95	%		
Relative Humidity - Operating	$RH_O$	0	95	%		
Soldering Temperature	$T_{sld}$	0	260	°C		
Soldering Time Duration	$t_{sld}$	0	10	seconds		
DC Supply Voltage	$V_{CC}$	0	6.0	VDC	5.0 VDC Models	
DC Supply Voltage	$V_{CC}$	0	4.0	VDC	3.3 VDC Models	

Recommended Operating Conditions ( $T_{amb} = 0$ to $+70^{\circ}\text{C}$ )						
Parameter	Symbol	Min	Typ	Max	Units	Notes
DC Supply Voltage	$V_{CC}$	3.135	3.30	3.465	Volts	3.3 Volt Models
DC Supply Voltage	$V_{CC}$	4.75	5.0	5.25	Volts	5.0 Volt Models
DC Supply Current (Transmitter)	$I_{CC}$	-	55	120	mA	
DC Supply Current (Receiver)	$I_{CC}$	-	85	100	mA	Not including load current
Tx Data Input Voltage (HIGH)	$V_{IH}-V_{CC}$	-1.1	-	-0.74	V	
Tx Data Input Voltage (LOW)	$V_{IL}-V_{CC}$	-2.0	-	-1.58	V	
Tx Data Differential Input Voltage	$V_{DIF}$	550	-	1700	mVp-p	
Rx Data Output Voltage (HIGH)	$V_{IH}-V_{CC}$	-1.1	-	-0.74	V	
Rx Data Output Voltage (LOW)	$V_{IL}-V_{CC}$	-2.0	-	-1.58	V	
Rx Data Output AC Voltage	$V_{opp}$	-	800	-	mVp-p	Single terminal

Transmitter Optical and Electrical Characteristics ( $T_{amb} = 0$ to $+70^{\circ}\text{C}$ )						
Parameter	Symbol	Min	Typ	Max	Units	Notes
Transmitter Type		1310 nm F-P Laser				
Center Wavelength	$\lambda_c$	1270	1310	1350	nm	1.3 $\mu\text{m}$ F-P laser
Spectral Width (RMS)	$\Delta\lambda$	-	2	7	nm	-
Optical Rise / Fall Time	$T_r / T_f$	-	-	2	ns	20% to 80%
Total Jitter	$T_J$	-	-	2.2	ns	
Extinction Ratio	ER	10	-	-	dB	
Average Output Optical Power	$P_o$	-20	-	-14	dBm	
Optical Output Eye		ITU-T G.957 compliant (PRBS 2 <sup>23</sup> -1 test pattern @155Mbps)				



## LTS1321 1x9 155 Mb/s SM Optical Transceiver

### ATM, FDDI, Fast Ethernet, OC-3, 1310 nm, 2 km, 5.0 V

#### Receiver Electro-Optical Characteristics (Tamb = 0 to +70°C)

Parameter	Symbol	Min	Typ	Max	Units	Notes
Receiver Type		1310 nm InGaAs PIN				
Receiver Optical Sensitivity	Pin	-	-	-32	dBm	BER = 1 <sup>-10</sup>
Receiver Optical Overload	Pin max	-7	-	-	dBm	-
Center Wavelength	$\lambda$	1100	1310	1600	nm	-
Rx_DATA+/- Output Load Impedance	R <sub>OL</sub>	-	50	-	Ohms	To (Vcc-2V)
SD (LVPECL) Output Load Impedance	R <sub>SDL</sub>	-	50	-	Ohms	To (Vcc-2V)
Signal Detect Range	P <sub>SD</sub>	-45	-	-32.5	dBm	AC Optical Signal
Signal Detect Hysteresis	P <sub>A</sub> -P <sub>D</sub>	0.5	-	4	dB	-

#### SC Package Electrical Interface and Pin Description

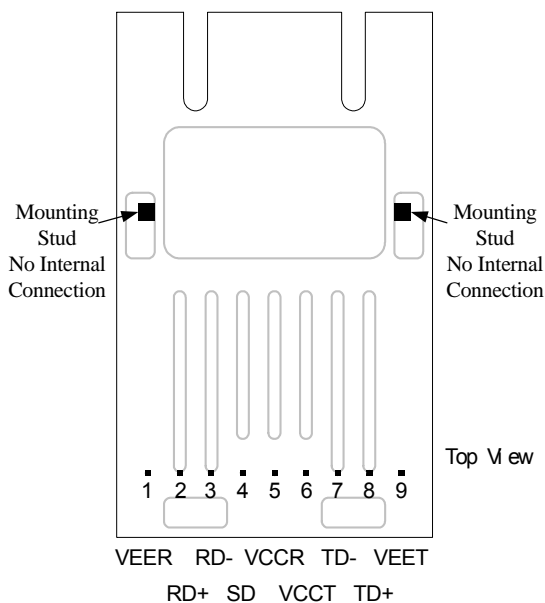

Pin	Symbol	Function
1	VEER	Receiver DC and Signal Ground
2	RD+	Rx_DATA Non-Inverted Differential Signal Output
3	RD-	Rx_DATA Inverted Differential Signal Output
4	SD	Rx_SD, LOW = No Signal, HIGH = Normal Operation
5	VCCR	Rx Positive Supply - Connected to Vcc
6	VCCT	Tx Positive Supply - Connected to Vcc
7	TD-	Tx_DATA Inverted Differential Signal Input
8	TD+	Tx_DATA Non-Inverted Differential Signal Input
9	VEET	Transmitter DC and Signal Ground

#### Operating Notes

- When Rx\_SD is LOW, the Rx\_DATA Non Inverted output goes LOW
- When Rx\_SD is LOW, the Rx\_DATA Inverted output goes HIGH
- When the optical input signal is above the receiver detection threshold, the Rx\_SD monitor goes HIGH
- When the optical input signal is below the receiver detection threshold, the Rx\_SD monitor goes LOW
- The Rx\_DATA output and the Tx\_DATA input differential I/O ports are PECL or LVPECL
- The single-ended Rx\_SD monitor port interface is PECL or LVPECL



## LTS1321 1x9 155 Mb/s SM Optical Transceiver

### ATM, FDDI, Fast Ethernet, OC-3, 1310 nm, 2 km, 5.0 V

#### APPLICATIONS INFORMATION

##### Transceiver Block Diagram

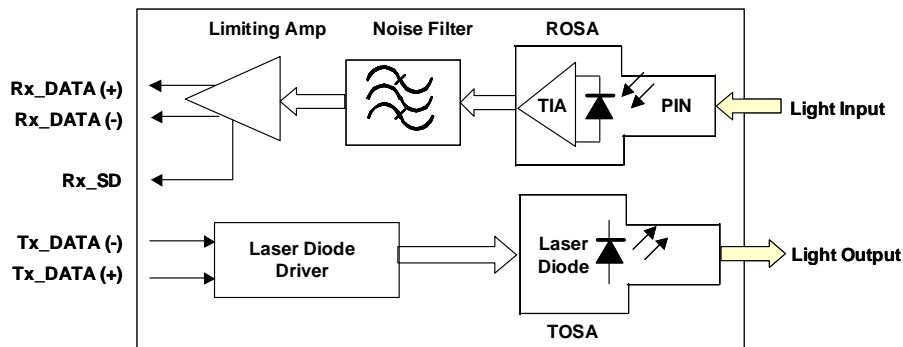

##### Transmitter Section

The transmitter incorporates optical and electrical subassemblies. The transmitting optical subassembly (TOSA) incorporates the high-speed Laser Diode and is characterized by its high efficiency and reliability, low threshold current and operating current and long life.

The transmitter electrical subassembly incorporates the PECL or LVPECL differential interface and high performance laser driver.

##### Receiver Section

The receiver incorporates optical and electrical subassemblies. The receiver optical subassembly (ROSA) incorporates a planar InGaAs PIN photo detector and the optical input receptacle. The high-reliability photo detector is characterized by its low dark current. The receiver electronics includes an integrated low noise preamplifier and AGC amplifier (TIA), which are mounted in a TO-Metal Can assembly with the photo detector. The output of the TIA drives the band pass filter (BPF) that limits the noise contribution of the received signal and improves the overall sensitivity of the receiver. The filtered BPF signal drives the small signal limiting amplifier. The differential output of the limiting amplifier is designed to drive PECL or LVPECL interface circuits. The receiver monitor function, Rx\_SD, is designed to operate with a PECL or LVPECL logic interface.

##### Electrical Interface Circuit

Electrical Interface Circuit Component Values

Interface	R1	R2	R5	R6	C1	C2	L1
3.3 V / LVPECL	82 Ω	130 Ω	130 Ω	82 Ω	100 nF	10 μF	1 μHy
5.0 V / PECL	82 Ω	130 Ω	130 Ω	82 Ω	100 nF	10 μF	1 μHy

##### Notes

- High-speed circuit design rules and impedance matching are recommended for optimum performance.
- The recommended I/O termination is 50 ohms.
- Although differential signal transmission is preferred, single ended operation may be used.
- The bypass capacitors should be rated for RF service.
- The power supply de-coupling chokes should be rated for RF service and should have low series resistance.

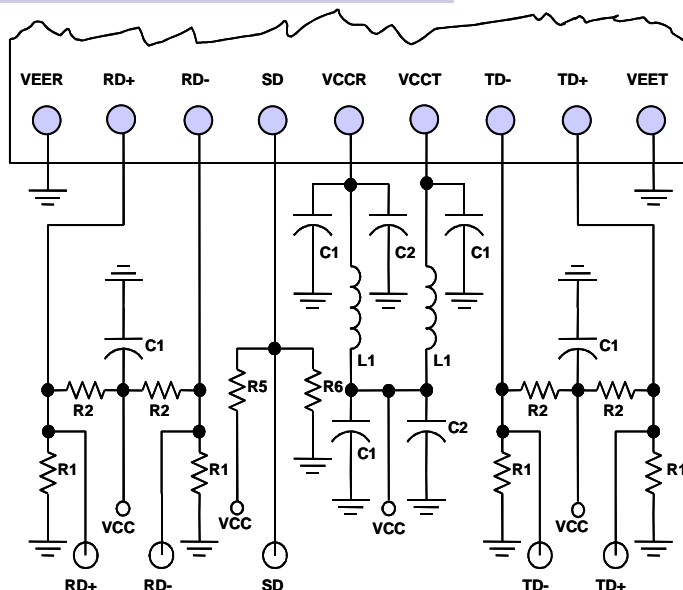



# LTS1321 1x9 155 Mb/s SM Optical Transceiver

## ATM, FDDI, Fast Ethernet, OC-3, 1310 nm, 2 km, 5.0 V

### 1x9 Duplex Transceiver with SC Duplex Receptacle

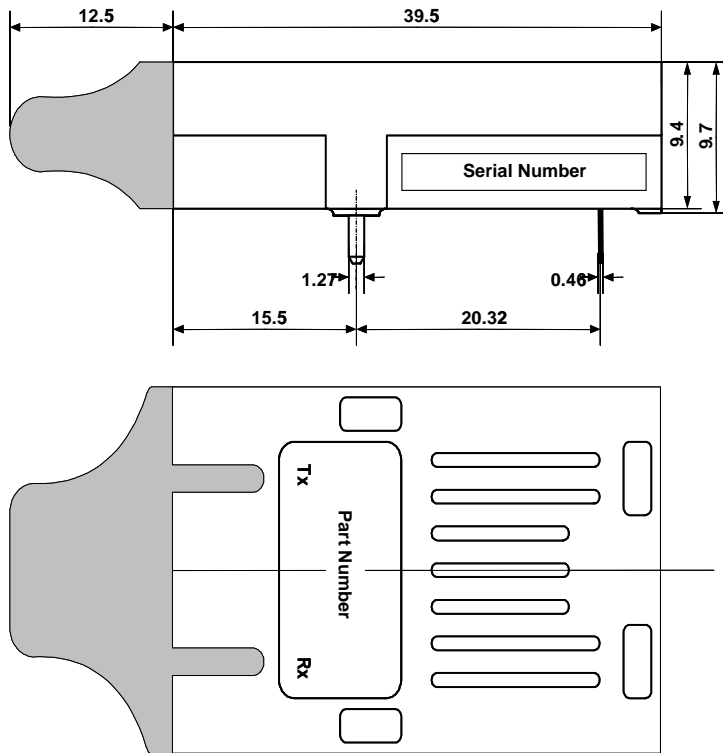

- Dimensions are in millimeters
- The holes for the mounting studs are 1.9 mm diameter
- The holes for the 9 electrical pins are 0.8 mm diameter
- Dimensional tolerances are  $\pm 0.1$ mm unless otherwise specified

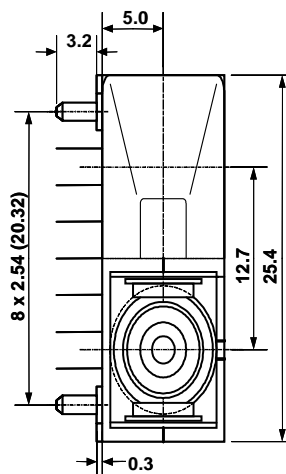

### Regulatory Requirements

#### Eye Safety

The transceiver is a Class 1 eye-safe device according to FDA 21CFR1040.10 and IEC 60825-2.

#### Electromagnetic Interference (EMI), Immunity and Product Safety

The transceiver is ESD safe (electrical pins) when tested according to MIL-STD-883, Method 3015.7 and ESD safe (optical connector) when tested according to IEC 61000-4-2. The device is immune to strong RF fields when tested in accordance with IEC 61000-4-3. The device complies with (US) FCC, Part 15, Subpart J; (Europe) CENELEC EN 55022; (Canada) Class B (CISPR22A); and (Japan) VCCI Class 1. The device has been designed to conform to product safety requirements including UL1950, CSA 22.2, and IEC 60950-1, and has been designed to meet the flammability requirements of UL94.

#### Notice

The factory has made all adjustments to this device prior to shipment. No adjustments or modifications to the device are required or permitted. Any adjustment, modification or tampering of the device voids the product warranty. The US Food and Drug Administration may consider that any adjustment or modification to this device is an act of manufacturing and therefore will require that the device be recertified in accordance with 21 CFR 1040.10 Subpart j.

Laser Radiation Information	
Wavelength	1310 nm
FDA Total Pout: 7 mm aperture at 20 cm distance	< 195 microwatts
IEC Total Pout : 7 mm aperture at 10 cm distance	< 15,600 microwatts
Beam Divergence	17.25°

#### Required Label

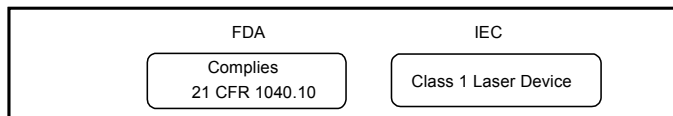

#### Laser Emission

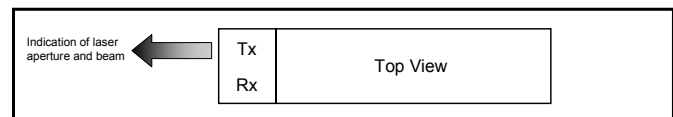

**FDA Accession Number 0421999**