

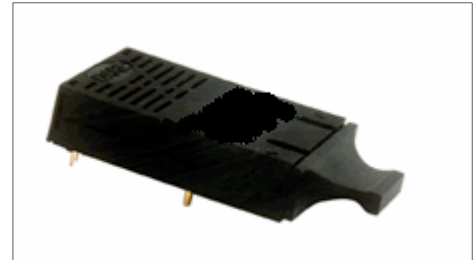

Product Description

The LTS1313 series of 1x9 622 Mb/s duplex optical transceivers are designed for 40 km reach applications in high speed LAN and SAN SONET OC-3 and SDH STM-1 optical communications equipment where low-cost, low power consumption, extraordinary performance and reliability are essential. They meet the requirements of Telcordia SONET OC-12 / LR-1 and ITU-T G.957 SDH STM-4 / L-4.1 and are housed in compact MSA compliant 1x9 plastic packages with integral FC, ST or SC duplex optical receptacles. The DC operating voltage options include 3.3 or 5.0 volts and the temperature options include the commercial, extended or industrial temperature ranges. The Class 1 laser transmitter incorporates a high-performance 1310 nm F-P optical subassembly, which is compliant with the international safety standard IEC6082-5. The laser driver electronics includes the differential PECL or LVPECL signal interface. The optical receiver incorporates a high-performance InGaAs PIN photo detector and high sensitivity TIA. The quantizer consists of the post amplifier, signal detector and differential PECL or LVPECL signal interface. The Rx_SD receiver monitor function is available with either the TTL / LVTTTL or PECL / LVPECL interface. These devices may be connected for either AC or DC-coupling



Duplex SC 1x9 Transceiver

Applications

- 622 Mb/s SONET/SDH telecom equipment
- Back to Back system interconnects
- Metro / Access Networks
- Switch to switch interfaces
- Hub interconnects
- Bus extenders
- Channel extenders
- Host adapter interconnects
- Mass storage system interconnects
- Telecom switches
- Router interconnects

Features

- SC / FC / ST Duplex optical interface
- 40 km reach
- 622 Mb/s data rate
- +3.3 V or +5 V power supply
- Low DC power consumption
- 1x9 MSA compliant package
- High performance 1310 nm F-P laser
- High sensitivity PIN/TIA optical receiver:
- Single Mode operation
- BER < 1X10⁻¹⁰ (2²³ - 1 NRZ PRBS test pattern)
- Telcordia SONET OC-12/ LR-1 compliant
- ITU-T G.957 SDH STM-4/ L-4.1 compliant
- Operating temperature range:
- Commercial: 0 to 70°C
- Extended: -10 to 80°C
- Industrial: -40 to 85°C

HOW TO ORDER

Part Number	PackageT ype (W)		Operating Voltage (X)		Rx_SD Option (Y)		Temperature Option (Z)	
LTS1309 WXYZ	S	SC Receptacle	3	3.3 V	T	TTL/LVTTL	C	0 to 70 °C
	F	FC Receptacle	5	5.0 V	P	PECL/LVPECL	E	-10 to 80 °C
	T	ST Receptacle					H	-40 to 85 °C



Absolute Maximum Ratings					
Parameter	Symbol	Min	Max	Units	Notes
Storage Temperature	T_{stg}	-40	100	°C	
Operating Temperature	T_{amb}	0	70	°C	Temp Option "C"
Operating Temperature	T_{amb}	-10	80	°C	Temp Option "E"
Operating Temperature	T_{amb}	-40	85	°C	Temp Option "H"
Relative Humidity - Storage	RH_S	0	95	%	
Relative Humidity - Operating	RH_O	0	95	%	
Soldering Temperature	T_{sld}	0	260	°C	
Soldering Time Duration	t_{sld}	0	10	seconds	
DC Supply Voltage (3.3 Volt Models)	V_{CC}	0	3.6	VDC	
DC Supply Voltage (5.0 Volt Models)	V_{CC}	0	5.45	VDC	

Recommended Operating Conditions						
Parameter	Symbol	Min	Typ	Max	Units	Notes
DC Supply Voltage	V_{CC}	3.14	3.30	3.46	Volts	3.3 Volt Models
		4.75	5.0	5.25	Volts	5.0 Volt Models
Data Input High	$V_{IH}-V_{CC}$	-1.17		-0.88	V	
Data Input Low	$V_{IL}-V_{CC}$	-1.81		-1.48	V	

Transmitter Optical and Electrical Characteristics						
Parameter	Symbol	Min	Typ	Max	Units	Note
Power Supply Current	I_{cct}	-	55	-	mA	+5 V
		-	50	-		+3.3 V
Differential Input Voltage	V_{id}	550	-	1750	mV	+5 V
		350	-	1750		+3.3 V
Data Input Impedance (Single terminal)	R_i	4.5	-	100	K Ohm	+5 V
		2.5	-	100		+3.3 V
Center Wavelength	λ_c	1270	1310	1350	nm	
Spectral Width (RMS)	$\Delta\lambda$	-	1.5	-	nm	F-P Laser
Optical Rise Time	t_r	55	-	255	ps	20% ~ 80%
Optical Fall Time	t_f	50	-	250	ps	20% ~ 80%
Extinction Ratio	ER	10	-	-	dB	-
Average Output Optical Power	P_o	-3	-	0	dBm	-
Optical Output Eye	ITU-T G.957 compliant (PRBS 2 ²³ -1 test pattern @622 Mbps)					



Receiver Electro-Optical Characteristics						
Parameter	Symbol	Min	Typ	Max	Units	Notes
Receiver Type	PIN / TIA					
Receiver DC Operating Current (Not Including Output Load Current)	I _{CCR}	-	85	-	mA DC	5.0 Volt Models
		-	80	-		3.3 Volt Models
Receiver Optical Sensitivity	Pin	-	-	-28	dBm	-
Receiver Optical Overload	Pin max	-3	-	-	dBm	-
Center Wavelength	λ	1100	1310	1670	nm	-
Data Output Voltage Swing (Single Ended)	V _{out}	-	800	-	mV pk-pk	Single Ended Operation
Rx_DATA+/- Output Load Impedance	R _{OL}	-	50	-	Ohms	To (Vcc-2V)
SD (PECL / LVPECL) Output Load Impedance	R _{SDL}	-	50	-	Ohms	To (Vcc-2V)
Rx_DATA Output Rise Time	t _r	-	250	-	ps	20%~80%
Rx_DATA Output Fall Time	t _f	-	250	-	ps	20%~80%
Rx_DATA Output Voltage (LOW)	VOH - VCC	-1.84	-	-1.62	V	50 Ohms to (Vcc-2V)
Rx_DATA Output Voltage (HIGH)	VOL - VCC	-1.05	-	-0.88	V	50 Ohms to (Vcc-2V)
Rx_SD Output (LOW)	V _{OL}	-	-	0.8	V	10 k Ohm Pull Up
Rx_SD Output (HIGH)	V _{OL}	2.0	-	-	V	10 k Ohm Pull Up
Signal Detection Range	PSD	-45	-	S-0.5	dBm	AC Optical Signal
Signal Detection Hysteresis	PA-PD	-	3	-	dB	-



APPLICATIONS INFORMATION

1x9 Pin Assignment

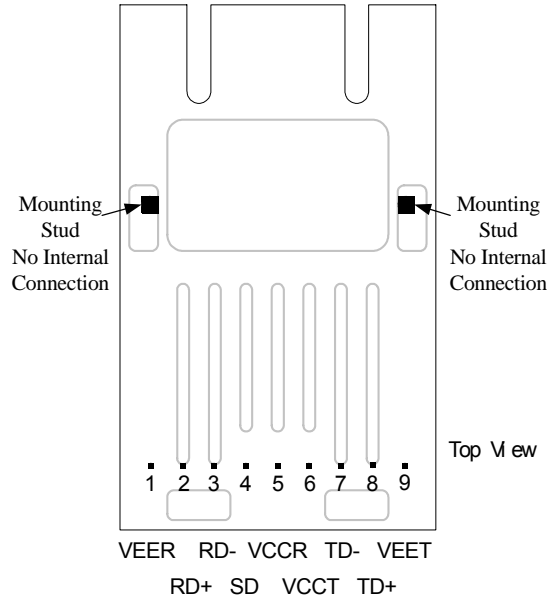

Pin	Symbol	Function
1	VEER	Receiver DC and Signal Ground
2	RD+	Rx_DATA Non-Inverted Differential Signal Output
3	RD-	Rx_DATA Inverted Differential Signal Output
4	SD	Rx_SD, LOW = No Signal, HIGH = Normal Operation
5	VCCR	Rx Positive Supply - Connected to +5.0 or 3.3 VDC
6	VCCT	Tx Positive Supply - Connected to +5.0 or 3.3 VDC
7	TD-	Tx_DATA Inverted Differential Signal Input
8	TD+	Tx_DATA Non-Inverted Differential Signal Input
9	VEET	Transmitter DC and Signal Ground

Operating Notes

- When Rx_SD is LOW, the Rx_DATA Non Inverted output goes LOW
- When Rx_SD is LOW, the Rx_DATA Inverted output goes HIGH
- When the optical input signal is above the receiver detection threshold, the Rx_SD monitor goes HIGH
- When the optical input signal is below the receiver detection threshold, the Rx_SD monitor goes LOW
- The Rx_DATA output and the Tx_DATA input differential I/O ports are either PECL or LVPECL depending upon the part number
- The Rx_SD monitor port interface can be PECL, LVPECL, TTL or LVTTTL depending upon the part number.



APPLICATIONS INFORMATION

Transceiver Block Diagram

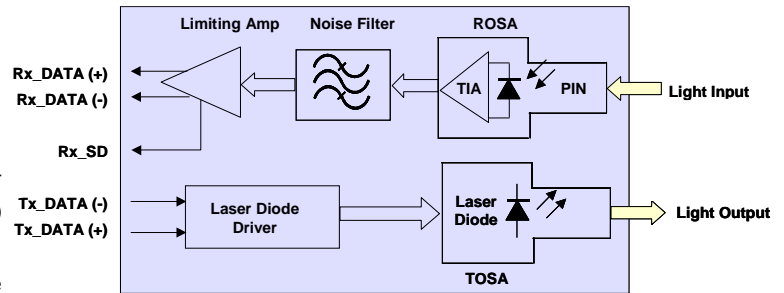

Transmitter Section

The transmitter incorporates optical and electrical subassemblies. The transmitting optical subassembly (TOSA) incorporates the high-speed laser diode and the optical output receptacle. The high performance MQW laser diode

is characterized by its high efficiency and reliability, low threshold current and operating current and long life. The transmitter electrical subassembly incorporates the PECL or LVPECL differential interface and high performance laser driver.

Receiver Section

The receiver incorporates optical and electrical subassemblies. The receiver optical subassembly (ROSA) incorporates a planar InGaAs PIN photo detector and the optical input receptacle. The high-reliability photo detector is characterized by its low dark current. The receiver electronics includes an integrated low noise preamplifier and AGC amplifier (TIA), which are mounted in a TO-Metal Can assembly with the photo detector. The output of the TIA drives the band pass filter (BPF) that limits the noise contribution of the received signal and improves the overall sensitivity of the receiver. The filtered BPF signal drives the small signal limiting amplifier. The differential output of the limiting amplifier, which is part number dependent, can drive PECL or LVPECL interface circuits. The receiver monitor function, Rx_SD, can be coupled to TTL, LVTTTL, PECL or LVPECL interfaces and is model dependent.

Electrical Interface Circuit

Electrical Interface Circuit Component Values							
Interface	R1	R2	R5	R6	C1	C2	L1
5 V / PECL	130 Ω	82 Ω	82 Ω	130 Ω	100 nF	10 μF	1 μHy
3.3 V / LVPECL	82 Ω	130 Ω	130 Ω	82 Ω	100 nF	10 μF	1 μHy
5 V / TTL Rx_SD	130 Ω	82 Ω	10k Ω	Note	100 nF	10 μF	1 μHy

Note: R5 is the TTL pull up resistor, R6 is not used

Notes

- High-speed circuit design rules and impedance matching are recommended for optimum performance.
- The recommended I/O termination is 50 ohms.
- Although differential signal transmission is preferred, single ended operation may be used.
- The bypass capacitors should be rated for RF service.
- The power supply de-coupling chokes should be rated for RF service and should have low series resistance.

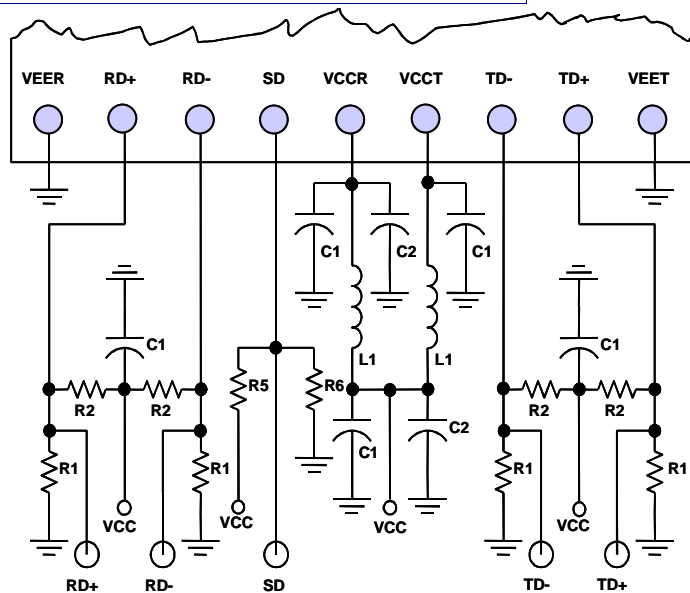



APPLICATIONS INFORMATION

Optional Transmitter Interface Circuits

PECL DC Coupling

Two methods of DC Coupling PECL or LVPECL drivers to the Tx_DATA input are presented.

- One terminal is shown. The other terminal should be terminated in the same way. DC Coupling eliminates the DC blocking capacitor.
- Case 1 - the terminating resistor "R1" is connected to (VCC - 2.0) VDC. The value of "R" is 50 ohms.
- Case2 - the terminating resistor is connected to ground. The value of "R1" is 270 ohms for 5.0 volt operation or 150 ohms for 3.3 volt operation.

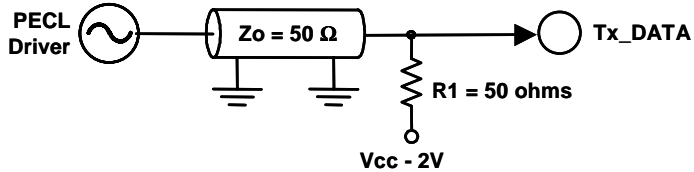

Case 1 - DC Coupling

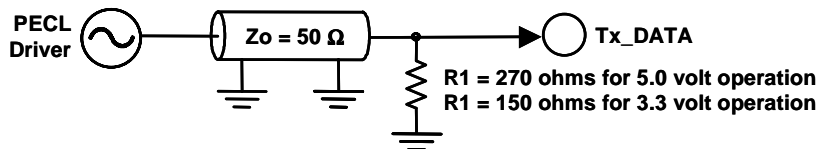

Case 2 - DC Coupling

Optional Transmitter Interface Circuits

PECL and NON-PECL AC Coupling

The methods of AC Coupling a PECL or Non-PECL driver source to the Tx_DATA input are presented.

One terminal is shown. The other terminal should be terminated in the same way.

- AC-Coupling a RF or Non-PECL signal source to the 50 ohm load does not require a terminating resistor.
- AC-Coupling a PECL signal source to the 50 load requires a terminating resistor as presented in the table. The value of R is determined by the operating voltage.
- The values of R1 and R2 are dependent upon the operating voltage. The values are presented in the table

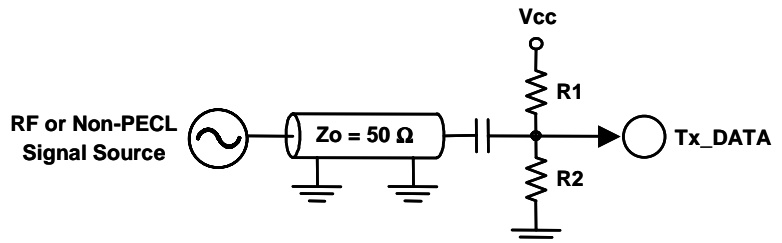

AC Coupling for RF or Non-PECL Signal Source

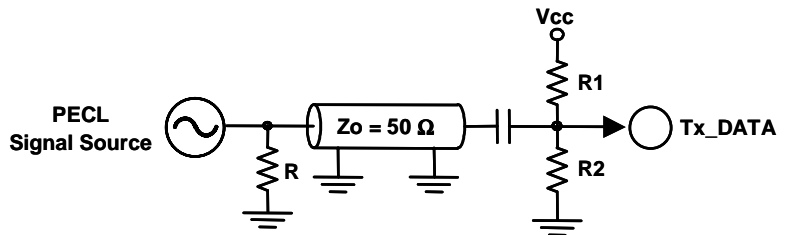

AC Coupling for PECL Signal Source

Resistor Values for Tx_DATA AC Coupling			
VCC	R	R1	R2
5.0 V	330 Ω	68 Ω	180 Ω
3.3 V	180 Ω	82 Ω	127 Ω



APPLICATIONS INFORMATION

**Optional Receiver Interface Circuits
DC or AC Coupling to High Z Loads**

The method of DC or AC-Coupling to a high impedance load is presented.

- One terminal is shown. The other terminal should be terminated in the same way.
- DC-Coupling requires connecting R1 to (VCC - 2.0 V). A terminating resistor at the Rx_Data port is not required.
- AC-Coupling requires a terminating resistors at the Rx_Data port according to the table.

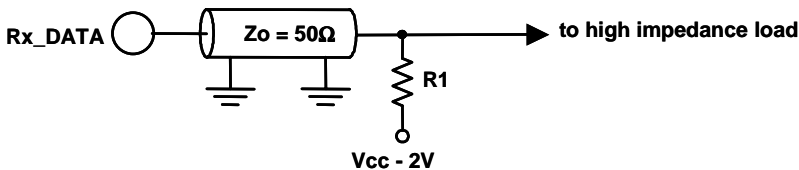

Receiver DC Coupling

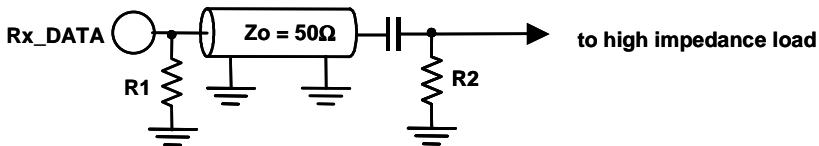

Receiver AC Coupling

Resistor Values for Rx_DATA AC and DC Coupling

VCC	Coupling	R1	R2
5.0 V	DC	50 Ω	None
3.3 V	DC	50 Ω	None
5.0 V	AC	270 - 330 Ω	560 Ω
3.3 V	AC	150 - 180 Ω	560 Ω

1x9 Duplex Transceiver with SC Duplex Receptacle

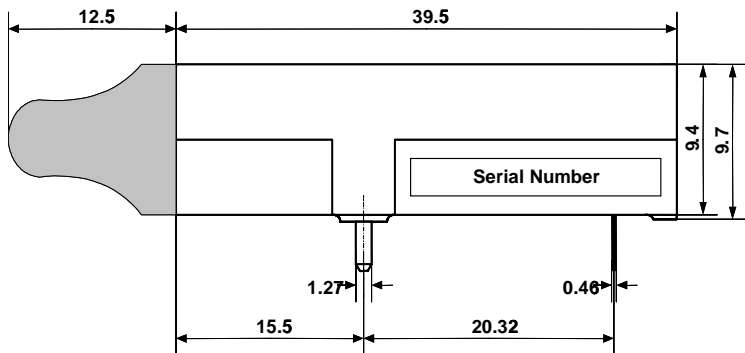

- Dimensions are in millimeters
- The holes for the mounting studs are 1.9 mm diameter
- The holes for the 9 electrical pins are 0.8 mm diameter
- Dimensional tolerances are ± 0.1mm unless otherwise specified

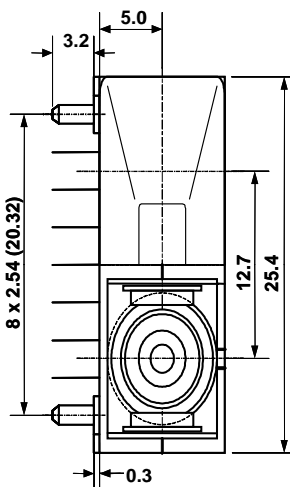
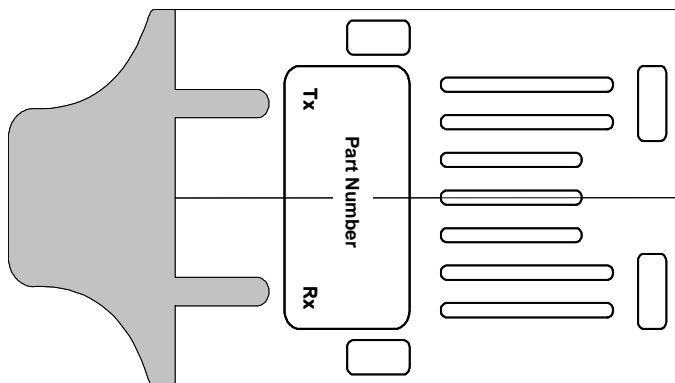



1x9 Duplex Transceiver with ST Duplex Receptacle

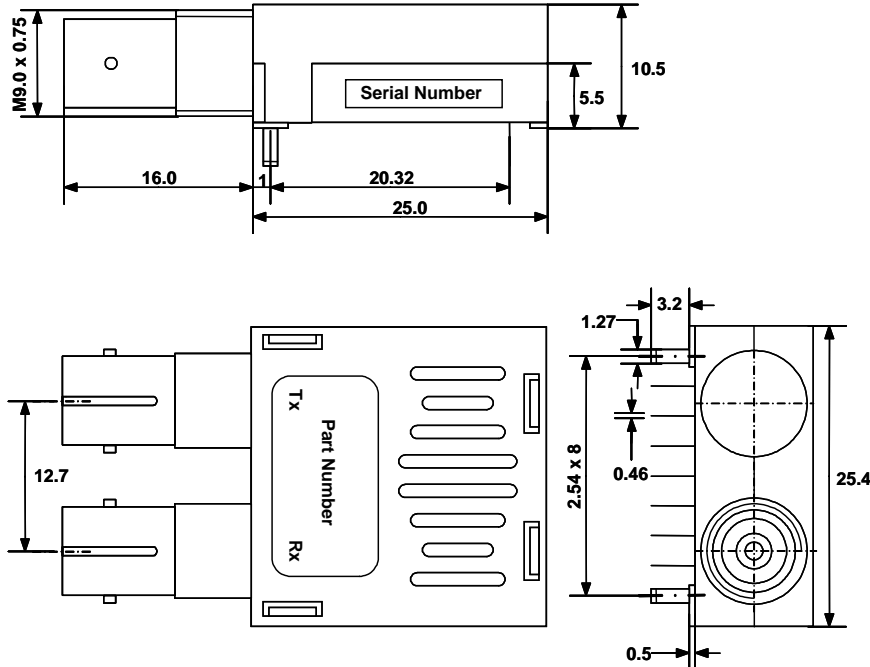

- Dimensions are in millimeters
- The holes for the mounting studs are 1.9 mm diameter
- The holes for the 9 electrical pins are 0.8 mm diameter
- Dimensional tolerances are ± 0.1 mm unless otherwise specified

1x9 Duplex Transceiver with FC Duplex Receptacle

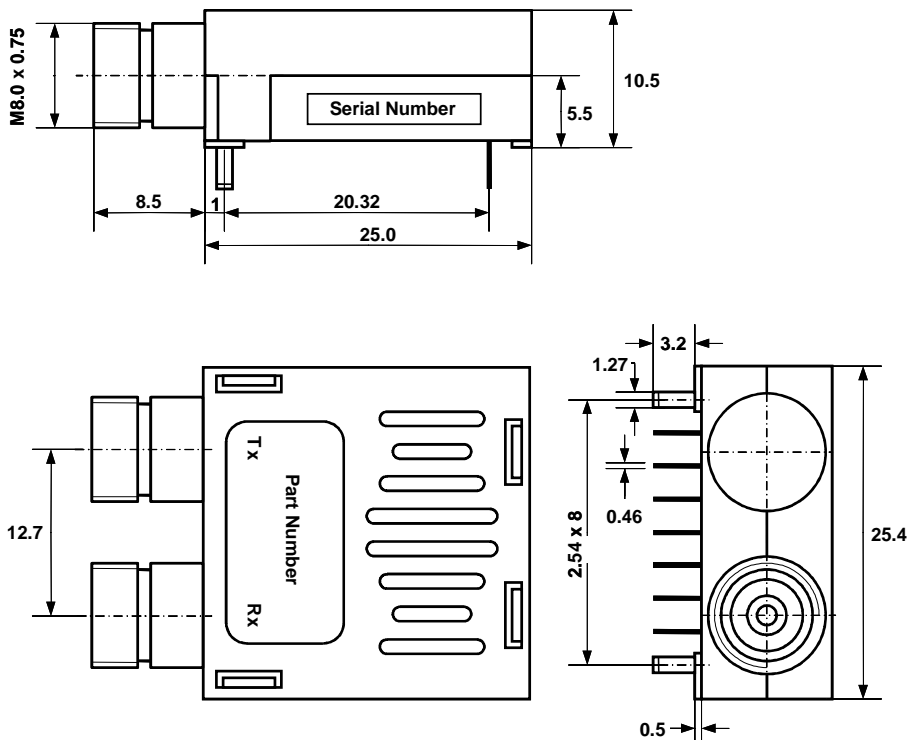

- Dimensions are in millimeters
- The holes for the mounting studs are 1.9 mm diameter
- The holes for the 9 electrical pins are 0.8 mm diameter
- Dimensional tolerances are ± 0.1 mm unless otherwise specified



Regulatory Information

Eye Safety

The transceiver is a Class 1 eye-safe device according to FDA 21CFR1040.10 and IEC 60825-2.

Electromagnetic Interference (EMI), Immunity and Product Safety

The transceiver is ESD safe (electrical pins) when tested according to MIL-STD-883, Method 3015.7 and ESD safe (optical connector) when tested according to IEC 61000-4-2. The device is immune to strong RF fields when tested in accordance with IEC 61000-4-3. The device complies with (US) FCC, Part 15, Subpart J; (Europe) CENELEC EN 55022; (Canada) Class B (CISPR22A); and (Japan) VCCI Class 1. The device has been designed to conform to product safety requirements including UL1950, CSA 22.2, and IEC 60950-1, and has been designed to meet the flammability requirements of UL94.

Notice

The factory has made all adjustments to this device prior to shipment. No adjustments or modifications to the device are required or permitted. Any adjustment, modification or tampering of the device voids the product warranty. The US Food and Drug Administration may consider that any adjustment or modification to this device is an act of manufacturing and therefore will require that the device be recertified in accordance with 21 CFR 1040.10 Subpart j.

Laser Radiation Information

Wavelength	1310 nm
FDA Total Pout: 7 mm aperture at 20 cm distance	< 195 microwatts
IEC Total Pout : 7 mm aperture at 10 cm distance	< 15,600 microwatts
Beam Divergence	17.25°

Required Label

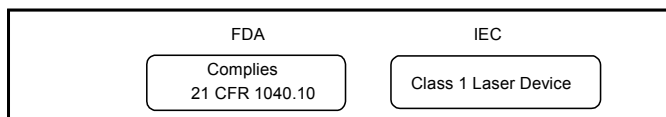

Laser Emission

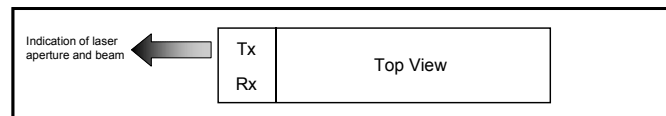

Ligent Sales Offices - USA

Ligent Photonics, Inc.

2701 Dukane Drive
Suite 200
St. Charles, IL 60174
PH (630) 513-7226
FX (630) 513-9173
WS www.ligentphotonics.com

Ligent Photonics, Inc.

(Virginia Sales Office)
8210 Strathmore Lane
Roanoke, VA 24019
PH (540) 797-5793
FX (540) 366-5793
WS www.ligentphotonics.com

New Age Electronics

3000 Northwood's Parkway
Suite 280
Norcross, GA 30071
PH (770) 242-8800
FX (770) 242-8180
WS www.newagelec.com

New Age Electronics

8376 Six Forks Road
Suite 202
Raleigh, NC 27615
PH (919) 866-0620
FX (919) 866-0621
WS www.newagelec.com

New Age Electronics

4940 Corporate Drive
Suite B
Huntsville, AL 35805
PH (256) 430-8000
FX (256) 430-8414
WS www.newagelec.com

K-Tech Sales

100 Century Center Court
Suite 405
San Jose, CA 95112
PH (408) 437-1808
FX (408) 437-1883
WS www.ktechsales.com

Kruvand Associates

1202 Richardson Drive
Suite 113
Richardson, TX 75080
PH (972) 437-3355
FX (972) 680-8854
WS www.kruvand.com

Kruvand Associates

8100 Shoal Creek Boulevard
Suite 250
Austin, TX 75080
PH (512) 454-1111
FX (512) 454-9858
WS www.kruvand.com

Kruvand Associates

10601 Grant Road
Suite 104
Houston, TX 77070
PH (713) 956-6741
FX (713) 972-680-8854
WS www.kruvand.com

VAL Technical Sales

183 Prospect Street
Hingham, MA 02043
PH (781) (781) 749-8358
FX (781) 740-4663
WS www.valtechnical.com

Ligent Sales Offices - Asia

Hisense Optoelectronics Technology Co., Limited

No.11, Jiangxi Road
Qingdao, Shandong
China 266071
PH 86 (532) 601-0000
FX 86 (532) 601-6007
WS www.hisenseopto.com

Summit Hisense Company, Limited

Triton Square
Office Tower Z 19F 1-8-12
Harumi Chuo-ku 104-6219
Japan
PH 81-3-5547-1252
FX 81-3-5547-1268