



The LTD1510-WL SFP LC duplex family of CWDM transceivers transceiver is intended for 40 km reach service in 155 Mb/s ~ 2.67Gb/s, 1470 to 1610 nm single mode high-speed telecommunications equipment where low-cost, extraordinary performance and reliability are essential. They consume low power and operate from a single 3.3 volt DC power supply. The industry standard 2x10 small form plug-gable (SFP) package is fabricated with a rugged die cast metal housing and cage assembly. The low jitter and low bit error rate optical assemblies features a DFB laser transmitter and PIN/TIA receiver. They incorporate the SFP MSA LVTTTL Loss of Signal (Rx\_LOS), Tx Fault (Tx\_FAULT) and Tx Disable (Tx\_DIS) monitor and control functions and the SFF-8472 Rev 9.3 compliant digital diagnostic monitor feature which is accessed via the I<sup>2</sup>C 2-wire serial ID interface. The differential AC coupled Tx and Rx data interfaces (50 ohms to ground, 100 ohms line to line) are LVPECL compatible. The devices are Class I laser safety compliant and operate over the temperature range of 0°C to +70°C.



#### APPLICATIONS

- SONET / SDH ATM
- Fibre Channel
- Gigabit Ethernet
- Rack to Rack System Interconnects
- Metro / Access Networks
- Switch to Switch Interfaces
- Hub Interconnects
- Bus Extenders
- Channel Extenders
- Host Adapter Interconnects
- Mass storage System Interconnects
- Telecom Switches
- Router Interconnects
- File Servers

#### FEATURES

- LC Duplex Optical Interface
- 40 km reach
- 18 dB Link Budget
- 155 Mb/s ~ 2670 Mb/s Data Rate
- +3.3 V Power Supply
- Low DC Power Consumption
- 2x10 SFP MSA Compliant Package
- Bail or Pull latch Option
- Hot Swappable
- 1470 to 1610 nm CWDM DFB Lasers
- Low Dispersion Penalty
- High Sensitivity PIN/TIA Optical Receiver
- Single Mode Operation
- BER < 1X10<sup>-10</sup> (2<sup>23</sup> - 1 NRZ PRBS)
- 0°C to +70°C Operating Temperature

#### ELECTRICAL INTERFACE

- Rx\_DATA Output
  - Differential LVPECL
  - AC-Coupled, Not Terminated
  - 100 Ohms Line to Line
- Tx\_DATA Input
  - Differential LVPECL
  - AC-Coupled, Internally Terminated
  - 100 Ohms Line to Line
- Rx\_LOS Monitor Output
  - Open Collector LVTTTL
  - External 4.7K to 10K Ohm Pull Up
- Tx\_FAULT Monitor Output
  - Open Collector LVTTTL
  - External 4.7K to 10K Ohm Pull Up
- Tx\_DISABLE Control Input
  - LVTTTL
  - Internal 4.7K to 10K Ohm Pull Up

#### DIAGNOSTIC MONITOR INTERFACE

- 2-wire I<sup>2</sup>C Data Bus
- SFF-8472 Rev 9.3 MSA Compliant
- Real Time Module Monitor
  - DC Voltage
  - DC Current
  - Module Temperature
  - Tx Output Power
  - Rx Input Power
- Serial Clock Input (SCL)
  - Open Collector LVTTTL
  - External 4.7K to 10K Pull Up
  - 100 KHz Clock Rate
- Bidirectional Data I/O (SDA)
  - Open Collector LVTTTL
  - External 4.7K to 10K Pull Up



**Ligent**

intelligent photonics

# LTD1510-WL CWDM SFP Optical Transceivers

155Mb/s ~ 2.67Gb/s 1470 nm to 1610 nm 40 km

## Absolute Maximum Ratings (EXCEEDING THESE RATINGS MAY CAUSE IRREVERSIBLE DAMAGE TO THE DEVICE)

Parameter	Symbol	Minimum	Maximum	Units
Storage Temperature	T <sub>stg</sub>	-40	+85	°C
Case Temperature (Operating)	T <sub>case</sub>	0	+70	°C
Relative Humidity - Storage	RH <sub>S</sub>	0	95	%
Relative Humidity - Operating	RH <sub>O</sub>	0	85	%
Tx DC Supply Voltage	V <sub>CCT</sub>	-0.3	3.6	V
Rx DC Supply Voltage	V <sub>CCR</sub>	-0.3	3.6	V
Soldering Temperature	T <sub>slid</sub>	0	260	°C
Soldering Time Duration	t <sub>slid</sub>	0	10	seconds
Tx DATA Differential Input Voltage	V <sub>IN PK-PK</sub>	0	2.4	V <sub>pk-pk</sub>
MOD_DEF 1, 2 Input Voltage Logic HIGH State	V <sub>IH</sub>	-	V <sub>CC</sub> +0.5	V
MOD_DEF 1, 2 Input Voltage Logic LOW State	V <sub>IL</sub>	-0.5	-	V
MOD_DEF 1 Clock Signal	I <sub>CLOCK</sub>	100	-	kHz
Tx_DISABLE Logic HIGH State	Tx_DISABLE	-	V <sub>CC</sub> +0.5	V
Tx_DISABLE Logic LOW State	Tx_DISABLE	-0.5	-	V
Tx_FAULT Logic HIGH State	Tx_FAULT	-	V <sub>CC</sub> +0.5	V
Tx_FAULT Logic LOW State	Tx_FAULT	-0.5	-	V
Rx_LOS Logic HIGH State	Rx_LOS	-	V <sub>CC</sub> +0.5	V
Rx_LOS Logic LOW State	Rx_LOS	-0.5	-	V
Rx Optical Input Power	P <sub>IN-MAX</sub>		3	dBm

## Ordering Information

Latch Options	Bail and Pull Latches are compatible with the dimensions defined by the SFP MSA
Case Operating Temperature	Commercial

Part Number	Wavelength
LTD1510-47 XYZ	1470 nm
LTD1510-49 XYZ	1490 nm
LTD1510-51 XYZ	1510 nm
LTD1510-53 XYZ	1530 nm
LTD1510-55 XYZ	1550 nm
LTD1510-57 XYZ	1570 nm
LTD1510-59 XYZ	1590 nm
LTD1510-61 XYZ	1610 nm

Schedule of LTD1501-WL XYZ Ordering Options			
Option	X	Y	Z
Bail Latch Option	B		
Pull Latch Option	P		
Commercial Temperature Range Option		C	
Non-RoHS Compliant Option			Blank
RoHS Complaint Option			R



**Ligent**

intelligent photonics

# LTD1510-WL CWDM SFP Optical Transceivers

155Mb/s ~ 2.67Gb/s 1470 nm to 1610 nm 40 km

## Recommended Operating Conditions

Parameter	Symbol	Min	Typ	Max	Units	Notes
Ambient Operating Temperature	T <sub>amb</sub>	0	25	+70	°C	Temperature Range = C
DC Supply Voltage	V <sub>CC</sub>	3.14	3.30	3.46	Volts	
Module Supply Current	I <sub>IN</sub>	-	150	200	mA	
Power Dissipation	P <sub>D</sub>	-	500	700	mW	

## SFF 8472 Revision 9.3 I<sup>2</sup>C Serial ID Logic Interface

Parameter	Function	Logic State	Logic Type	Min	Max	Units
MOD_DEF 0	Digital Ground	Ground	N/A	0	0.8	V (Note 1)
MOD_DEF 1	Clock Signal	HIGH	LVTTL	2.4	V <sub>CC</sub> +0.3	V (Note 1)
		LOW	LVTTL	0	0.8	V (Note 1)
MOD_DEF 2	Serial Data	HIGH	LVTTL	2.4	V <sub>CC</sub> +0.3	V (Note 1)
		LOW	LVTTL	0	0.8	V (Note 1)

Note 1: MOD\_DEF 0, MOD\_DEF 1 and MOD\_DEF 2 each require a 4.7K to 10K ohm pull-up resistor on the Host PCB

## Transmitter Logic

Parameter	Symbol	Min	Max	Units	Notes
Tx_DISABLE Logic HIGH State	T <sub>XDH</sub>	2.4	V <sub>CC</sub> +0.3	V	Tx DISABLED - LVTTL (Note 1)
Tx_DISABLE Logic LOW State	T <sub>XDL</sub>	0	0.8	V	Tx ENABLED - LVTTL (Note 1)
Tx_DISABLE Input Current Logic HIGH State	I <sub>DIS</sub>	-1	50	mA	
Tx_DISABLE Assert Time	t <sub>off</sub>	-	10	µs	
Tx_DISABLE Deassert Time	t <sub>on</sub>	-	1	ms	
Tx_DISABLE Initialization Period	t <sub>init</sub>	-	300	ms	From Power On
Tx_FAULT Logic HIGH State	T <sub>XFH</sub>	2.4	V <sub>CC</sub> +0.3	V	Tx is OFF - LVTTL (Note 2)
Tx_FAULT Logic LOW State	T <sub>XFL</sub>	0	0.8	V	Tx is ON - LVTTL (Note 2)
Tx_FAULT Assert Time	t <sub>fault</sub>	-	100	µs	After FAULT Occurs
Tx_FAULT Reset Time	t <sub>reset</sub>	10	-	µs	Tx_DISABLE Must Be Held HIGH to RESET

Note 1: Tx\_DISABLE is a control input and is internally connected to 4.7K to 10K ohm pull-up resistor

## Parameter

Parameter	Symbol	Min	Max	Units	Notes
Rx_LOS Logic HIGH State	V <sub>Ioh</sub>	2.4	V <sub>CC</sub> +0.3	V	Rx is OFF/NO SIGNAL - LVTTL (Note 1)
Rx_LOS Logic LOW State	V <sub>Iol</sub>	0	0.8	V	Rx is ON/NORMAL - LVTTL (Note 1)
Rx_LOS ASSERT Time	t <sub>LOS_on</sub>	2.3	100	µs	Period from LOS State to Rx_LOS Assert
Rx_LOS DEASSERT Time	t <sub>LOS-off</sub>	-	350	µs	Period from non-LOS State to Rx_Deassert

Note 1: Rx\_LOS is a monitor output and requires an external 4.7K to 10K ohm pull-up resistor on the Host PCB



Transmitter Electro-Optical Characteristics						
Parameter	Symbol	LTD1510-WL			Units	Notes
		Min	Typ	Max		
Laser Type		CWDM DFB				
Optical Output Power (Tx_ENABLED)	P <sub>o</sub>	0	-	5	dBm	Average Optical Output
Optical Output Power (Tx_DISABLED)	P <sub>o</sub>	-	-	-45	dBm	
Center Wavelength	λ <sub>C</sub>	1464.5	1470	1477.5	nm	Note 1
Center Wavelength	λ <sub>C</sub>	1484.5	1490	1497.5	nm	Note 1
Center Wavelength	λ <sub>C</sub>	1504.5	1510	1517.5	nm	Note 1
Center Wavelength	λ <sub>C</sub>	1524.5	1530	1537.5	nm	Note 1
Center Wavelength	λ <sub>C</sub>	1544.4	1550	1557.5	nm	Note 1
Center Wavelength	λ <sub>C</sub>	1564.5	1570	1577.5	nm	Note 1
Center Wavelength	λ <sub>C</sub>	1584.5	1590	1597.5	nm	Note 1
Center Wavelength	λ <sub>C</sub>	1604.5	1610	1617.5	nm	Note 1
Spectral Line Width@-20dB	Δλ	-	-	1	nm	
Extinction Ratio	ER	8.2	-	-	dB	
Side Mode Suppression Ratio	SMSR	30			dB	
Dispersion Penalty	DP	-	-	1.5	dB	Note 1, 2
Optical Rise and Fall Time	t <sub>r</sub> , t <sub>f</sub>	-	-	175	ps	20% - 80%
Bit Rate Range	Tx_BR	155	-	2670	Mb/s	
Relative Intensity Noise	RIN	-	-	-120	dB/Hz	
Total Peak to Peak Transmitter Jitter	J <sub>PK-PK</sub>			0.1	UI pk-pk	Note 3
Total RMS Transmitter Jitter	J <sub>RMS</sub>	-	-	0.01	UI RMS	Note 3
Output Eye		Telcordia GR-253 CORE and ITU-T G.957				
Tx Differential Input Impedance	Z <sub>in</sub>	-	100	-	Ohms	
Tx Differential Input Voltage	V <sub>IN</sub>	400	-	2400	mV p-p	LVPECL Tx DATA (Note 4)
Note 1: 2488.32 Mb/s data rate, 2 <sup>23</sup> -1 PRBS, 50% duty, NRZ Note 2: 1610 nm, 1,000 ps/nm Note 3: SONET / SDH OC048 / STM-16 data stream, 2 <sup>23</sup> -1 PRBS, Instrument LPF = 12 KHz cutoff, HPF = 20 MHz cutoff Note 4: Internally AC-coupled and terminated						



**Ligent**

intelligent photonics

# LTD1510-WL CWDM SFP Optical Transceivers

155Mb/s ~ 2.67Gb/s 1470 nm to 1610 nm 40 km

## Receiver Electro-Optical Characteristics

Parameter	Symbol	LTD1510-WL			Units	Notes	
		Min	Typ	Max			
Receiver Type		PIN / TIA					
Receiver Optical Sensitivity	2670 Mb/s	$P_{in}$	-	-	-18	dBm	Average Received Power (Note 1)
Receiver Optical Sensitivity	2488 Mb/s	$P_{in}$	-	-	-18	dBm	Average Received Power (Note 1)
Receiver Optical Sensitivity	2125 Mb/s	$P_{in}$	-	-	-18	dBm	Average Received Power (Note 2)
Receiver Optical Sensitivity	1063 / 1250 Mb/s	$P_{in}$	-	-	-19	dBm	Average Received Power (Note 2)
Receiver Optical Sensitivity	622 Mb/s	$P_{in}$	-	-	-19	dBm	Average Received Power (Note 3)
Receiver Optical Sensitivity	155 Mb/s	$P_{in}$	-	-	-19	dBm	Average Received Power (Note 3)
Receiver Optical Overload		$P_{in\ MAX}$	0	-	-	dBm	
Center Wavelength		$\lambda$	1260	1550	1620	nm	
Optical Return Loss		RL	-	-	-27	dB	
Data Bit Rate Range		Rx_BR	155	-	2670	Mb/s	
LOS - Signal Loss - Assert		$P_{SLA}$	-35	-	-18.5	dBm	
LOS - Signal Loss - Deassert		$P_{SLD}$	-34.5	-	-18	dBm	
LOS - Signal Loss - Hysteresis		$P_H$	0.5	2	6	dB	
Rx Differential Load Impedance		$Z_{LOAD}$	-	100	-	Ohms	(Note 4)
Rx Differential Output Voltage		$V_{OUT}$	400	-	1400	mV p-p	LVPECL Rx DATA (Note 4)
Data Output Rise / Fall Time		$t_r / t_f$	-	-	175	ps	(Note 5)
Receiver Reflectance		REFL	-	-	-27	dB	

Note 1: Average received power where the BER =  $10^{-10}$ , measured with a  $2^{23}$ -1 NRZ test pattern

Note 2: Average received power where the BER =  $10^{-12}$ , measured with a  $2^7$ -1 NRZ test pattern

Note 3: Average received power where the BER =  $10^{-10}$ , measured with a  $2^{23}$ -1 NRZ test pattern

Note 4: Internally AC coupled and externally terminated with 100 Ohms

Note 5: 20 - 80 %, 2488.32 Mb/s data rate,  $2^{23}$ -1 PRBS, 50% duty, NRZ



## TRANSCEIVER BLOCK DIAGRAM

### Transmitter Section

The transmitter section consists of a high reliability DFB laser diode (LD) of a wavelength between 1470 to 1610 nm with back facet monitor photo detector (PD) in an eye safe optical sub-assembly (TOSA), which is mated to the Tx port of the fiber optic LC duplex receptacle. A driver IC converts LVPECL differential input data signals into an analog current source that drives the LD. The transmitter is provided with the Tx\_Disable and Tx\_FAULT control and monitoring functions.

### Receiver Section

The receiver section consists of a high-speed InGaAs PIN photodiode and a transimpedance preamplifier mounted in an optical subassembly (ROSA), which is mated to the Rx port of the fiber optic LC duplex receptacle. The output of the PD drives the post-amplification, quantizing, and optical signal detection circuits. The receiver is equipped with the Rx\_LOS (Loss of Signal) monitoring function.

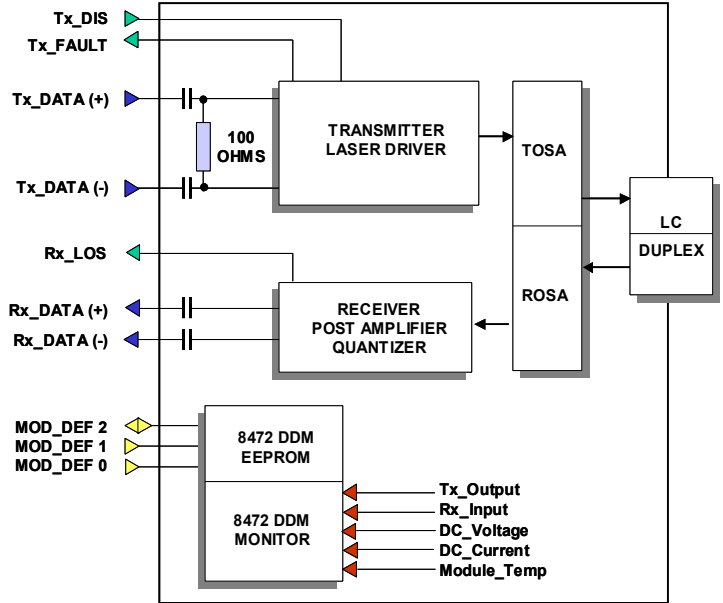

## MONITOR, CONTROL AND DIAGNOSTIC FUNCTIONS

### Rx Signal Loss (Rx\_LOS)

The Rx\_LOS (Loss of Signal) is an open collector LVTTTL output monitor port. It switches state based on the received optical input signal level that passes through the photo detector (PD), post amplifier and quantizer. If the received signal is above the Rx threshold, then Rx\_LOS is set LOW indicating normal operation. If the received signal is below the Rx threshold, then Rx\_LOS is set HIGH indicating a possible broken fiber, unplugged connector or low Tx signal from the host. The Rx\_LOS pin requires an external 4.7K to 10 K Ohm pull-up resistor.

### Tx Disable (Tx\_DIS)

The Tx\_DIS (Transmit Disable) is a LVTTTL control port that is controlled by a logic signal on the host (system) printed circuit board. If the system is ready to send data then the Tx\_DIS line is set LOW to enable the laser driver and the laser transmitter. If the system is not ready to send data, then the Tx\_DIS line is set HIGH to disable the transmitter.

### Tx Fault (Tx\_FAULT)

The Tx\_FAULT (Transmit Fault) is an open collector LVTTTL monitor port. It switches states based on the condition of the laser driver and the laser including the end of life condition of the laser. If the parameters of the laser driver and laser are within specifications then the Tx\_FAULT is set LOW indicating normal transceiver operation. If a fault occurs, including excess optical output power then Tx\_FAULT is set HIGH which disables the transmitter. The Tx\_FAULT can be reset to normal operation by toggling Tx\_DIS or switching the power supply. The Tx\_FAULT pin requires an external 4.7K to 10K Ohm pull-up resistor.

### 8472 Digital Diagnostic Monitor

SFF-8472 Rev 9.3 MSA digital diagnostics are enabled via the 2-wire I<sup>2</sup>C data bus:

MOD_DEF 0	Indicates module is present
MOD_DEF 1	Clock input
MOD_DEF 2	Two-way data port



#### SFP MSA and SFF 8472 REVISION 9.3 DIGITAL DIAGNOSTICS

This device incorporates the SFF-8472 Revision 9.3 digital diagnostic monitoring and control functions, which provide backward compatibility with the SFP-MSA digital diagnostic interface.

This device incorporates two 128-bytes data tables:

1. Table A0 (HEX) contains 128-bytes of information relating to the type of device as shown in the table below. The data is programmed into memory at the time the device is manufactured and is normally WRITE PROTECTED.
2. Table A2 (HEX) contains 128-bytes of real-time dynamic data from the internal calibration of the device, which includes the module temperature, the transmit output power, the receiver input power, the module DC operating current and the DC oper-

ating voltage. At the time the device is manufactured upper and lower WARNING and ALARM limits are stored in the EEPROM and WRITE PROTECTED. During operation, the stored values are compared with the real time data generated by the transceiver and a FLAG is SET if the WARNING or ALARM values are exceeded.

The SFF-8472 Revision 9.3 digital diagnostic interface enables the system host to discover the transceiver's parametric and data functions via a 2-wire system with one wire providing the clock and timing information and the other wire providing two-way communications with the transceiver. Additional information can be found in the SFF-8472 Rev 9.3 documentation.

Code Table for 8472 Digital Diagnostics - Page A0 HEX

Address	Bytes	HEX	DECIMAL	Name of Field	Field Description
00	1	03	3	ID Field	SFP transceiver
01	1	04	4	Extended ID Field	SFP function is defined by serial ID only
02	1	07	7	Connector ID Field	LC optical connector
06	1	14	20	Transceiver ID Field	OC-48 Long Reach, LR-1
11	1	05	5	Transceiver Encoding	SONET Scrambled
12	1	19	25	Nominal Bit Rate	2500 Mb/s
14	1	28	40	Link Length	40 km
15	1	FF	255	Link Length > 25.4 km	GBIC compatibility requirement
20 to 35	16	XX	XX	Vendor Name	Ligent Photonics
37 to 39	3	XX	XX	Vendor IEEE ID	TBD - assigned at time of production
40 to 55	16	XX	XX	Ligent Part Number	LTD1510-WL assigned at time of production
56 to 59	4	XX	XX	Ligent Rev Number	1.9 - assigned at time of production
60 to 61	2	XX	XX	Wavelength	See Wavelength Table Page 8
65	1	1A	26	SFP Codes	Rx LOS, Tx DIS, Tx FAULT
66, 67	1	XX	XX	Bit Rate Max Tolerance	20 percent - assigned at time of production
68 to 83	16	XX	XX	Ligent Serial Number	Assigned at time of production
84 to 91	8	XX	XX	Ligent Date Code	Assigned at time of production
92	1	68	104	Type of Diagnostics	Average Power, Internal Calibration, 8472 DDM
93	1	B0	176	Enhanced Options	Alarm / Warning Flags, Soft Fault, LOS
94	1	01	1	8472 Compatibility	Compatible with 8472 Rev 9.3



Address 60 and 61 - Wavelength Description				
Wavelength 25°C	Address 60 HEX (MSB)	Address 61 HEX (LSB)	16-BIT HEX Value (MSB+LSB)	DECIMAL Equivalent
1470 nm	05	BE	05BE	1470
1490 nm	01	EA	01EA	1490
1510 nm	05	E6	05E6	1510
1530 nm	05	FA	05FA	1530
1550 nm	06	0E	060E	1550
1570 nm	06	22	0622	1570
1590 nm	06	36	0636	1590
1610 nm	06	4A	064A	1510

**PAGE A2 (HEX) SFF 8472 REVISION 9.3 DIGITAL DIAGNOSTICS**

Page A2 (HEX) contains the ALARM, WARNING and ACTUAL data for 5 different transceiver parameters. The information is stored in the "two's-complement" format with the MSB occupying the lower byte and the LSB occupying the higher byte as shown in the table below. For each of the 5 parameters there are 10 memory locations:

1. High ALARM Value
2. Low ALARM Value
3. High WARNING Value
4. Low WARNING Values
5. Real Time Data

When an ALARM or WARNING value is reached, a FLAG is set that can be read by the I<sup>2</sup>C serial interface. The FLAG is a single bit in a specific 8-bit memory location. It is possible to have several ALARM and WARNING FLAGS set within a single 8-bit byte. In the table below, bytes 112, 113, 116 and 117 are the FLAG memory locations and the number in the parenthesis is the bit location with the 8-bit byte.

**SFF-8472 Rev 9.3 A2 (HEX) Address Table for Alarm and Warning Data**

8472 Parameter	Alarm Threshold Data				Warning Threshold Data				Measured Values		Alarm Bit (Set) Address + Position		Warning Bit (Set) Address + Position	
	High Value		Low Value		High Value		Low Value				High	Low	High	Low
	MSB	LSB	MSB	LSB	MSB	LSB	MSB	LSB	MSB	LSB	High	Low	High	Low
Temperature	00	01	02	03	04	05	06	07	96	97	112 (7)	112 (6)	116 (7)	116 (6)
Vcc	08	09	10	11	12	13	14	15	98	99	112 (5)	112 (4)	116 (5)	116 (4)
Tx Bias	16	17	18	19	20	21	22	23	100	101	112 (3)	112 (2)	116 (3)	116 (2)
Tx Out	24	25	26	27	28	29	30	31	102	103	112 (1)	112 (0)	116 (1)	116 (0)
Rx Input	32	33	34	35	36	37	38	39	104	105	113 (7)	113 (8)	117 (7)	117 (6)



**Ligent**

intelligent photonics

# LTD1510-WL CWDM SFP Optical Transceivers

155Mb/s ~ 2.67Gb/s 1470 nm to 1610 nm 40 km

## ELECTRICAL INTERFACE

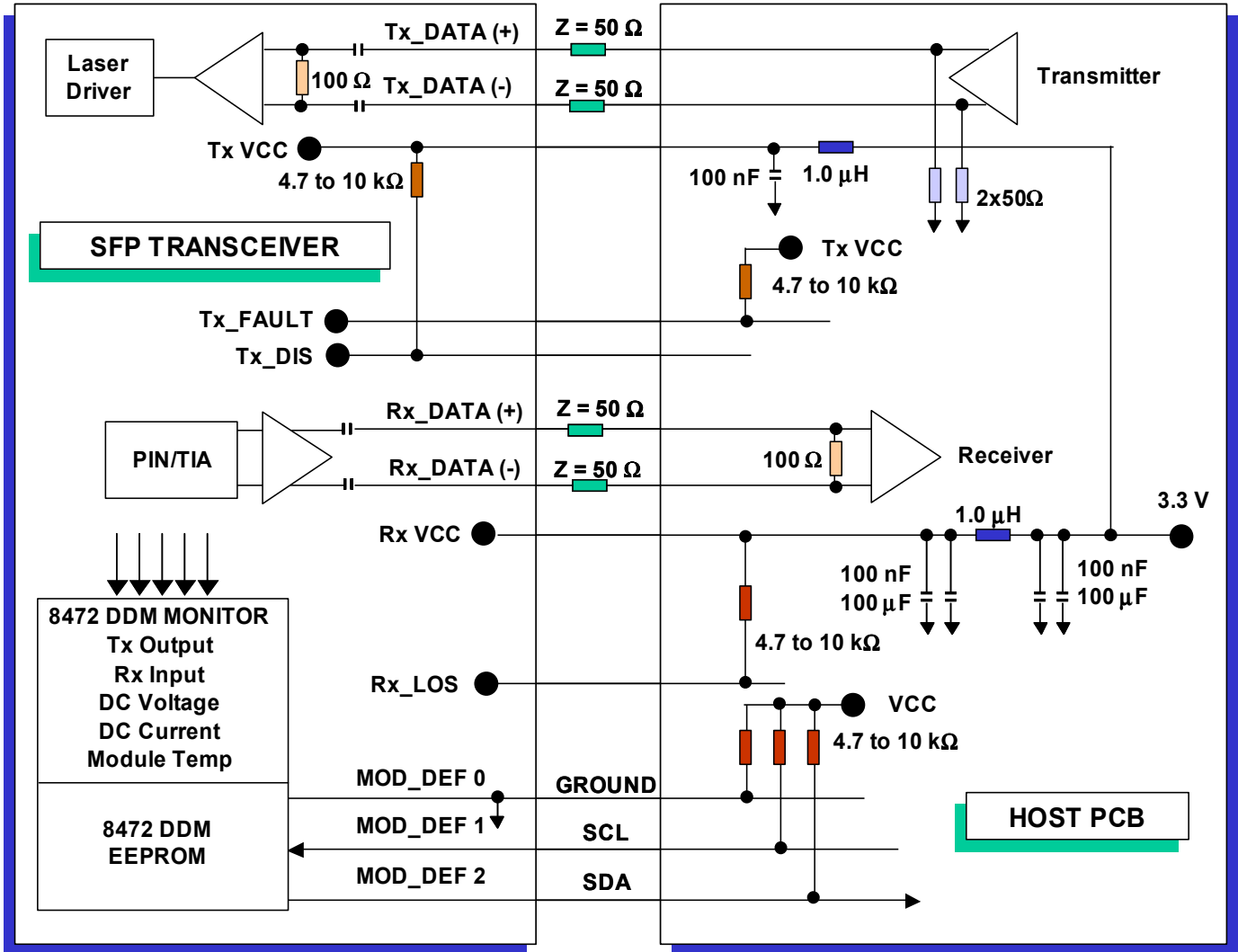



**Ligent**

intelligent photonics

# LTD1510-WL CWDM SFP Optical Transceivers

155Mb/s ~ 2.67Gb/s 1470 nm to 1610 nm 40 km

## Pin Assignment

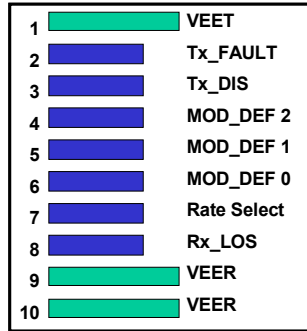
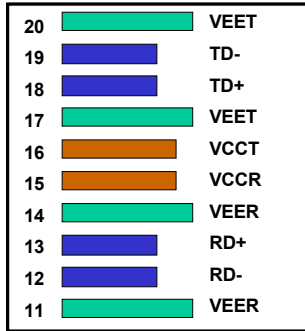

**Transceiver Electrical Pad Layout**  
Top View Bottom View

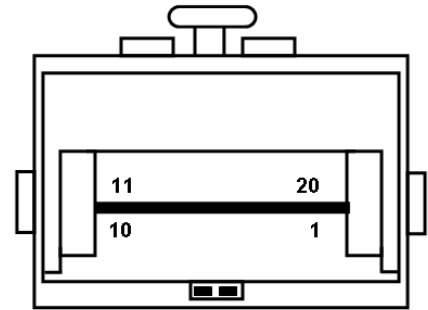

**Transceiver Pin Locations**

## SFP Pin Assignment

Pin	Symbol	Logic Type	Description	Notes
1	V <sub>EET</sub>	N/A	Transmitter Ground	
2	Tx_FAULT	LVTTL	Transmitter Fault, LOW = Normal Operation, HIGH = Fault Indication	Note 1
3	Tx_DIS	LVTTL	Transmit Disable, LOW = Normal Operation, HIGH = Disables Module	Note 1
4	MOD_DEF 2	LVTTL	Module Definition 2 - Two-Wire Interface - Serial Data	Note 1
5	MOD_DEF 1	LVTTL	Module Definition 1 - Two-Wire Interface - Clock Signal	Note 1
6	MOD_DEF 0	LVTTL	Module Definition 0 - Two-Wire Interface Digital Ground	
7	Rate Select	N/A	Not Connected	
8	Rx_LOS	LVTTL	Receiver Loss of Signal, LOW = Normal Operation, HIGH = Loss of Signal	Note 1
9	V <sub>EER</sub>	N/A	Receiver Ground	
10	V <sub>EER</sub>	N/A	Receiver Ground	
11	V <sub>EER</sub>	N/A	Receiver Ground	
12	RD-	LVPECL	Rx_Data Output (Inverted)	Note 2
13	RD+	LCPECL	Rx_Data Output (Non Inverted)	Note 2
14	V <sub>EER</sub>	N/A	Receiver Ground	
15	V <sub>CCR</sub>	N/A	Receiver DC Power	3.3 V +/- 5%
16	V <sub>CCT</sub>	N/A	Transmitter DC Power	3.3 V +/- 5%
17	V <sub>EET</sub>	N/A	Transmitter Ground	
18	TD+	LVPECL	Tx_Data Input (Non Inverted)	Note 3
19	TD-	LVPECL	Tx_Data Input (Inverted)	Note 3
20	V <sub>EET</sub>	N/A	Transmitter Ground	

1. The uncommitted Tx\_Fault, Rx\_LOS, MOD\_DEF 1 and MOD\_DEF 2 LVTTL monitor and control pins each require a pull up resistor of 4.7K to 10K Ohms.
2. The 100 Ohm differential Rx Data output is internally AC coupled and must be terminated with 100 Ohms at the differential user interface.
3. The 100 Ohm differential Tx\_DATA input is internally AC-coupled and terminated





**Ligent**

intelligent photonics

# LTD1510-WL CWDM SFP Optical Transceivers

155Mb/s ~ 2.67Gb/s 1470 nm to 1610 nm 40 km

## MECHANICAL DIMENSIONS - BAIL LATCH

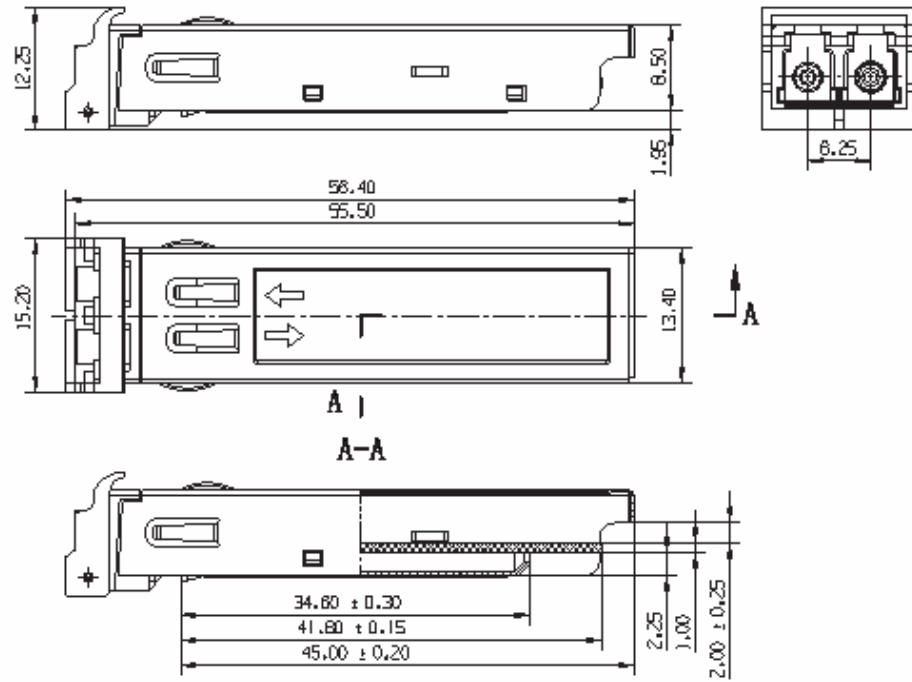

## MECHANICAL DIMENSIONS - PULL LATCH

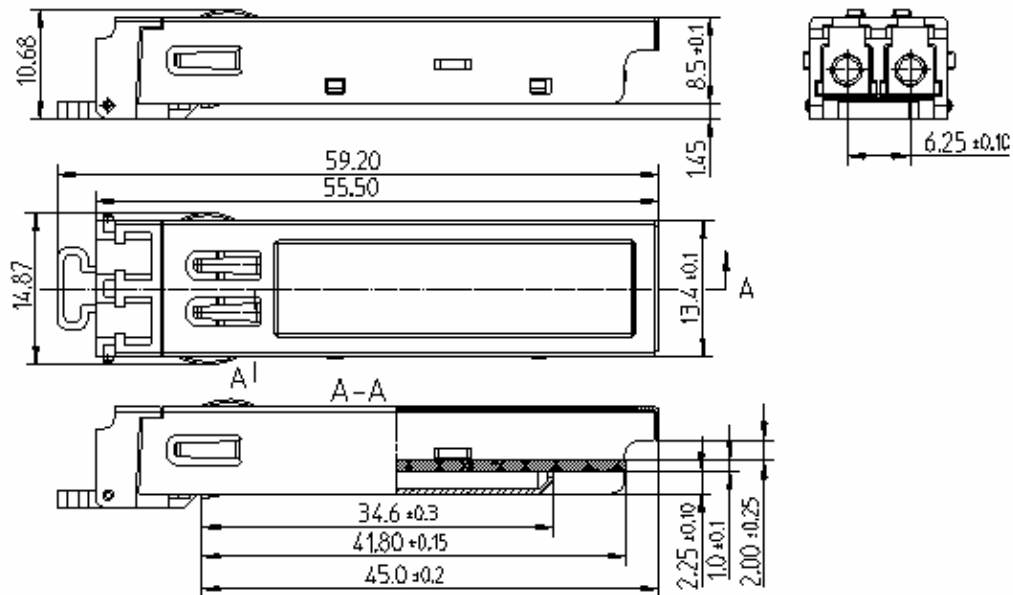

Dimensions are in millimeters  
Dimension tolerance is ± 0.1mm unless otherwise specified



REGULATORY INFORMATION

Eye Safety

The transceiver is a Class 1 eye-safe device according to FDA 21CFR1040.10 and IEC 60825-1. Do not attempt to look directly at the laser beam with naked eye or through optical equipment without suitable laser eye-safety glasses. Failure to observe this warning will result in permanent eye damage.

(Canada) Class B (CISPR22A); and (Japan) VCCI Class 1. The device has been designed to conform to product safety requirements including UL1950, CSA 22.2, and IEC 60950-1, and has been designed to meet the flammability requirements of UL94.

Notice

The factory has made all adjustments to this device prior to shipment. No adjustments or modifications to the device are required or permitted. Any adjustment, modification or tampering of the device voids the product warranty. The US Food and Drug Administration may consider that any adjustment or modification to this device is an act of manufacturing and therefore will require that the device be recertified in accordance with 21 CFR 1040.10.

Electromagnetic Interference (EMI), Immunity and Product Safety

The transceiver is ESD safe (electrical pins) when tested according to MIL-STD-883, Method 3015.7 and ESD safe (optical connector) when tested according to IEC 61000-4-2. The device is immune to strong RF fields when tested in accordance with IEC 61000-4-3. The device complies with (US) FCC, Part 15; (Europe) CENELEC EN 55022;

Laser Radiation Information	
Wavelength	1550 nm
FDA Total Pout: 7 mm aperture at 20 cm distance	< 195 microwatts
IEC Total Pout : 7 mm aperture at 14 cm distance	< 2000 microwatts
Beam Divergence	6°

Required Label

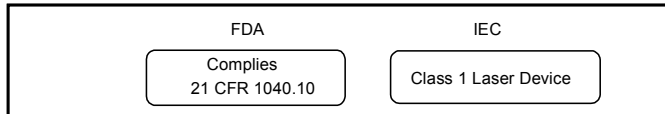

Laser Emission

