



#### Product Description

The LTD1398 SFP SONET/SDH LC duplex transceiver is intended for 15 km reach service in 622 Mb/s 1310 nm single mode high-speed telecommunications equipment where low-cost, extraordinary performance and reliability are essential. It meets the requirements of Telcordia SONET OC-12/IR-1 and ITU-T G.957 SDH STM-4/S-4.1, consumes low power, operates from a 3.3 volt DC power supply and is offered in the commercial, extended and industrial temperature ranges. The industry standard 2x10 small form pluggable (SFP) package is fabricated with a rugged die cast metal housing and cage assembly. The low jitter and low bit error rate optical assemblies features a 1310 nm F-P laser transmitter and PIN/TIA receiver. It incorporates the SFP MSA LVTTTL Loss of Signal (Rx\_LOS), Tx Fault (Tx\_FAULT) and Tx Disable (Tx\_DIS) monitor and control functions. The differential AC coupled Tx and Rx data interfaces (50 ohms to ground, 100 ohms line to line) are LVPECL compatible. The device is Class I laser safety compliant.



#### Applications

- 622 Mb/s SONET/SDH telecom equipment
- Hub interconnects
- Mass storage system interconnects
- Rack to rack system interconnects
- Bus extenders
- Telecom switches
- Metro / Access Networks
- Channel extenders
- Router interconnects
- Switch to switch interfaces
- Host adapter interconnects

#### Features

- LC Duplex optical interface
- BER < 1X10<sup>-10</sup> (2<sup>23</sup> - 1 NRZ PRBS test pattern)
- Tx Fault (Tx\_FAULT), LVTTTL
- 15 km reach
- Telcordia SONET OC-12/IR-1 compliant
- 2-wire I<sup>2</sup>C data bus
- 622 Mb/s data rate
- ITU-T G.957 SDH STM-4/S-4.1 compliant
- Internally AC coupled and terminated
- +3.3 V power supply
- Operating temperature range options:
- LVPECL Rx and Tx data interface
- Low DC power consumption
- Commercial: 0 to 70°C
- 100 Ohms differential (line to line)
- 2x10 SFP MSA compliant package
- Extended: -10 to 80°C
- 50 Ohms single ended (line to ground)
- Bail or pull latch option
- Industrial: -40 to 85°C
- Hot swappable
- Monitor and Control Functions
- High performance 1310 nm F-P laser
- Loss of Signal (Rx\_LOS), LVTTTL
- High sensitivity PIN/TIA optical receiver:
- Tx Disable (Tx\_DIS), LVTTTL
- Single Mode operation



**Absolute Maximum Ratings (EXCEEDING THESE RATINGS MAY CAUSE IRREVERSIBLE DAMAGE TO THE DEVICE)**

Parameter	Symbol	Minimum	Maximum	Units
Storage Temperature	T <sub>stg</sub>	-40	+85	°C
Relative Humidity - Storage	RH <sub>S</sub>	0	95	%
Relative Humidity - Operating	RH <sub>O</sub>	0	85	%
DC Supply Voltage	V <sub>CC</sub>	0	3.6	V
Soldering Temperature	T <sub>slid</sub>	0	260	°C
Soldering Time Duration	t <sub>slid</sub>	0	10	seconds
Tx DATA	V <sub>in</sub>	0	V <sub>CC</sub> + 0.5	V

**Optical and Electrical Signal Absolute Maximum Ratings**

Signal / Data Input Voltage (Tx_DATA )	V <sub>IN PK-PK</sub>	-	2.4	V
Rx Optical Input Power	P <sub>IN-MAX</sub>		3	dBm

**Logic State Absolute Maximum Ratings**

Tx_DISABLE Logic HIGH State	Tx_DIS	-	V <sub>CC</sub> +0.5	V
Tx_FAULT Logic HIGH State	Tx_FAULT	-	V <sub>CC</sub> +0.5	V
Rx_LOS Logic HIGH State	Rx_LOS	-	V <sub>CC</sub> +0.5	V

**Recommended Operating Conditions**

Parameter	Symbol	Min	Typ	Max	Units	Notes
Ambient Operating Temperature	T <sub>amb</sub>	0	25	+70	°C	Temperature Range = C
		-10	25	+80	°C	Temperature Range = E
		-40	25	+85	°C	Temperature Range = H
DC Supply Voltage	V <sub>CC</sub>	3.14	3.30	3.46	Volts	
Module Supply Current	I <sub>IN</sub>	-	130	180	mA	
Power Dissipation	P <sub>D</sub>	-	450	700	mW	

**Ordering Information**

Latch Options	Bail and Pull Latches are compatible with the dimensions defined by the SFP MSA
Ambient Operating Temperature	Commercial, Extended or Industrial

Part Number	Latch Option (X)		Temperature Option (Y)	
<b>LTD1398 XY</b>	B	Bail	C	0 to 70 °C
	P	Pull	E	-10 to 80 °C
			H	-40 to 85 °C



Transmitter Logic						
Parameter	Function	Logic State	Logic Type	Min	Max	Units
Tx DIS	DISABLE	HIGH	LVTTL	2.0	V <sub>CC</sub> +0.3	V
Tx DIS	ENABLE	LOW	LVTTL	0	0.8	V
Tx DIS	Assert Time	-	LVTTL	-	10	μs
Tx FAULT	FAULT	HIGH	LVTTL	2.0	V <sub>CC</sub> +0.3	V
Tx FAULT	NORMAL	LOW	LVTTL	0	0.8	V

Receiver Logic						
Parameter	Function	Logic State	Logic Type	Min	Max	Units
Rx_LOS	LOSS OF SIGNAL	HIGH	LVTTL	2.0	V <sub>CC</sub> +0.3	V
Rx_LOS	LOSS OF SIGNAL	LOW	LVTTL	0	0.8	V

Transmitter Electro-Optical Characteristics						
Parameter	Symbol	LTD1398			Units	Notes
		Min	Typ	Max		
Transmitter Type		1310 nm F-P				
Optical Output Power	P <sub>o</sub>	-15		-8	dBm	Average Optical Output
Center Wavelength	λ	1270	1310	1350	nm	
RMS Spectral Line Width	Δλ	-	2.5	-	nm	
Extinction Ratio	ER	8.2	-	-	dB	
Optical Rise and Fall Time	t <sub>r</sub> , t <sub>f</sub>	-	500	600	ps	20% - 80%
Relative Intensity Noise	RIN	-	-	-117	dB/Hz	
Transmitter Generated RMS Jitter	J <sub>RMS</sub>	-	-	0.007	UI	
Output Eye	ITU-T G.957 Compliant					
Tx Differential Input Impedance	Z <sub>in</sub>	-	100	-	Ohms	
Tx Differential Input Voltage	V <sub>IN</sub>	200	-	2400	mV p-p	LVPECL Tx DATA (Note 1)
Note 1: Internally AC coupled and terminated						



Receiver Electro-Optical Characteristics						
Parameter	Symbol	LTD1398			Units	Notes
		Min	Typ	Max		
Receiver Type		PIN / TIA				
Receiver Optical Sensitivity	$P_{IN}$	-	-	-28	dBm	Average Received Power (Note 1)
Receiver Optical Overload	$P_{IN MAX}$	-	-	-8	dBm	
Center Wavelength	$\lambda$	1260	1310	1360	nm	
Optical Return Loss	RL	12	-	-	dB	
Rx Upper 3 dB Cutoff Frequency	$f_c$	-	-	900	MHz	
Signal Loss - Assert	$P_{SLA}$	-42	-	-30.5	dBm	
Signal Loss - Deassert	$P_{SLD}$	-41.5	-	-30	dBm	
Signal Loss - Hysteresis	$P_H$	0.5	2	5	dB	
Data Output Rise / Fall Time	$t_r / t_f$		500	-	ps	20 - 80 %
Rx Differential Load Impedance	$Z_{LOAD}$	-	100	-	Ohms	
Rx Differential Output Voltage	$V_{OUT}$	300	-	1800	mV p-p	LVPECL Rx DATA (Note 2)
Note 1: Average received power where the BER = $10^{-10}$ , measured with a $2^{23}$ -1 NRZ test pattern						
Note 2: Internally AC coupled and terminated						

**Eye Diagram**

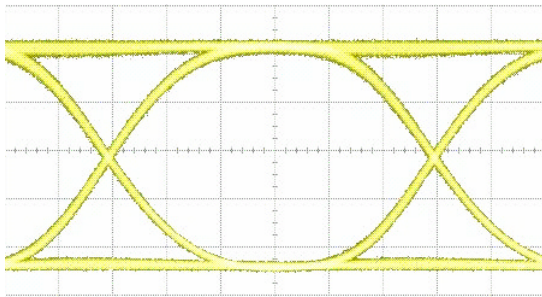

**Transmitter Test Conditions**

- Optical Output Power = **-10 dBm**
- Test Pattern =  $2^{23}$ -1 NRZ PRBS

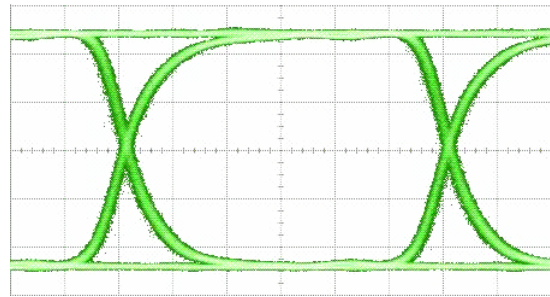

**Receiver Test Conditions**

- Optical Input Power = **-17 dBm**
- Test Pattern =  $2^{23}$ -1 NRZ PRBS



**Transceiver Block Diagram**

**Transmitter Section**

The transmitter section consists of a high reliability 1310 nm FP laser diode (LD) with back facet monitor photo detector (PD) in an eye safe optical sub-assembly (TOSA), which is mated to the Tx port of the fiber optic LC duplex receptacle. A driver IC converts LVPECL differential input data signals into an analog current source that drives the LD. The transmitter is provided with the Tx\_Disable and Tx\_FAULT control and monitoring functions.

**Receiver Section**

The receiver section consists of a high-speed InGaAs PIN photodiode and transimpedance preamplifier mounted in an optical subassembly (ROSA), which is mated to the Rx port of the fiber optic LC duplex receptacle. The output of the PD drives the post-amplification, quantizing, and optical signal detection circuits. The receiver is equipped with the Rx\_LOS (Loss of Signal) monitoring function.

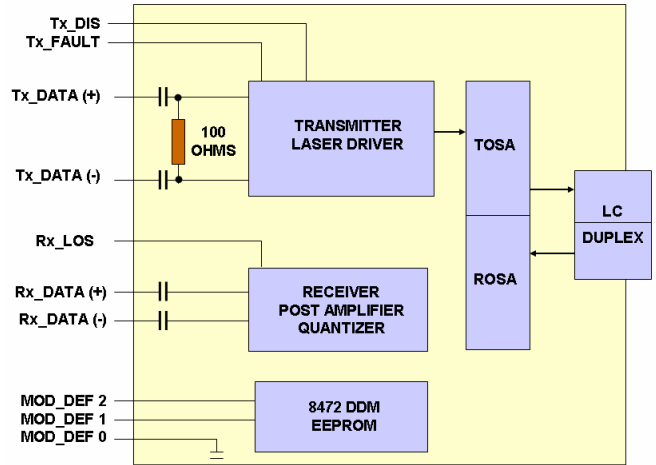

**Transceiver Monitor and Control Functions**

**Rx Signal Loss (Rx\_LOS) Description**

The Rx\_LOS (Loss of Signal) is an open collector LVTTTL monitor port. It switches state based on the received optical input signal level that passes through the photo detector (PD), post amplifier and quantizer. If the received signal is above the Rx threshold, then Rx\_LOS is set LOW indicating normal operation. If the received signal is below the Rx threshold, then Rx\_LOS is set HIGH indicating a possible broken fiber, unplugged connector or low Tx signal from the host. The Rx\_LOS pin requires an external 4.7K to 10 K Ohm pull-up resistor.

**Tx Disable (Tx\_DIS) Description**

The Tx\_DIS (Transmit Disable) is an open collector LVTTTL control port that is controlled by a logic signal on the host (system) printed circuit board. If the system is ready to send data then the Tx\_DIS line is set LOW to enable the laser driver and the laser transmitter. If the system is not ready to send data, then the Tx\_DIS line is set HIGH to disable the transmitter.

**Tx Fault (Tx\_FAULT) Description**

The Tx\_FAULT (Transmit Fault) is an open collector LVTTTL monitor port. It switches states based on the condition of the laser driver and the laser including the end of life condition of the laser. If the parameters of the laser driver and laser are within specifications then the Tx\_FAULT is set LOW indicating normal transceiver operation. If a fault occurs, including excess optical output power then Tx\_FAULT is set HIGH which disables the transmitter. The Tx\_FAULT can be reset to normal operation by toggling Tx\_DIS or switching the power supply. The Tx\_FAULT pin requires an external 4.7K to 10K Ohm pull-up resistor.



**Pin Assignment**

20	VEET
19	TD-
18	TD+
17	VEET
16	VCCT
15	VCCR
14	VEER
13	RD+
12	RD-
11	VEER

1	VEET
2	Tx_FAULT
3	Tx_DIS
4	MOD_DEF 2
5	MOD_DEF 1
6	MOD_DEF 0
7	Rate Select
8	Rx_LOS
9	VEER
10	VEER

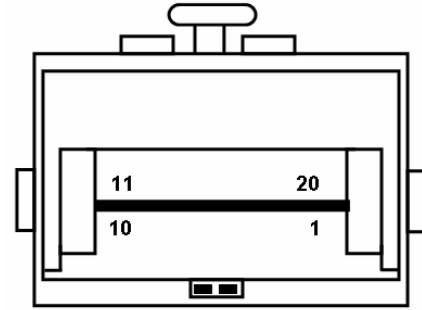
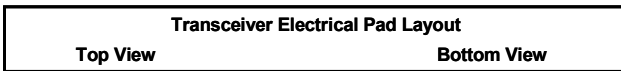

Transceiver Pin Locations

**SFP Pin Assignment**

Pin	Symbol	Logic Type	Description	Notes
1	V <sub>EET</sub>	N/A	Transmitter Ground	
2	Tx_FAULT	LVTTTL	Transmitter Fault, LOW = Normal Operation, HIGH = Fault Indication	Note 1
3	Tx_DIS	LVTTTL	Transmit Disable, LOW = Normal Operation, HIGH = Disables Module	Note 1
4	MOD_DEF 2	LVTTTL	Module Definition 2 - Two-Wire Interface - Serial Data	Note 1
5	MOD_DEF 1	LVTTTL	Module Definition 1 - Two-Wire Interface - Clock Signal	Note 1
6	MOD_DEF 0	LVTTTL	Module Definition 0 - Two-Wire Interface Digital Ground	
7	Rate Select	N/A	Not Connected	
8	Rx_LOS	LVTTTL	Receiver Loss of Signal, LOW = Normal Operation, HIGH = Loss of Signal	Note 1
9	V <sub>EER</sub>	N/A	Receiver Ground	
10	V <sub>EER</sub>	N/A	Receiver Ground	
11	V <sub>EER</sub>	N/A	Receiver Ground	
12	RD-	LVPECL	Rx_Data Output (Inverted)	Note 2
13	RD+	LCPECL	Rx_Data Output (Non Inverted)	Note 2
14	V <sub>EER</sub>	N/A	Receiver Ground	
15	V <sub>CCR</sub>	N/A	Receiver DC Power	3.3 V +/- 5%
16	V <sub>CCT</sub>	N/A	Transmitter DC Power	3.3 V +/- 5%
17	V <sub>EET</sub>	N/A	Transmitter Ground	
18	TD+	LVPECL	Tx_Data Input (Non Inverted)	Note 3
19	TD-	LVPECL	Tx_Data Input (Inverted)	Note 3
20	V <sub>EET</sub>	N/A	Transmitter Ground	

**Notes**

1	The uncommitted Tx_Fault, Rx_LOS, MOD_DEF 1 and MOD_DEF 2 LVTTTL monitor and control pins each require a pull up resistor of 4.7K to 10K Ohms.
2	The 100 Ohm differential Rx Data output is internally AC coupled and must be terminated with 100 Ohms at the differential user interface.
3	The 100 Ohm differential Tx Data input is internally AC coupled and terminated.



#### Electrical Interface

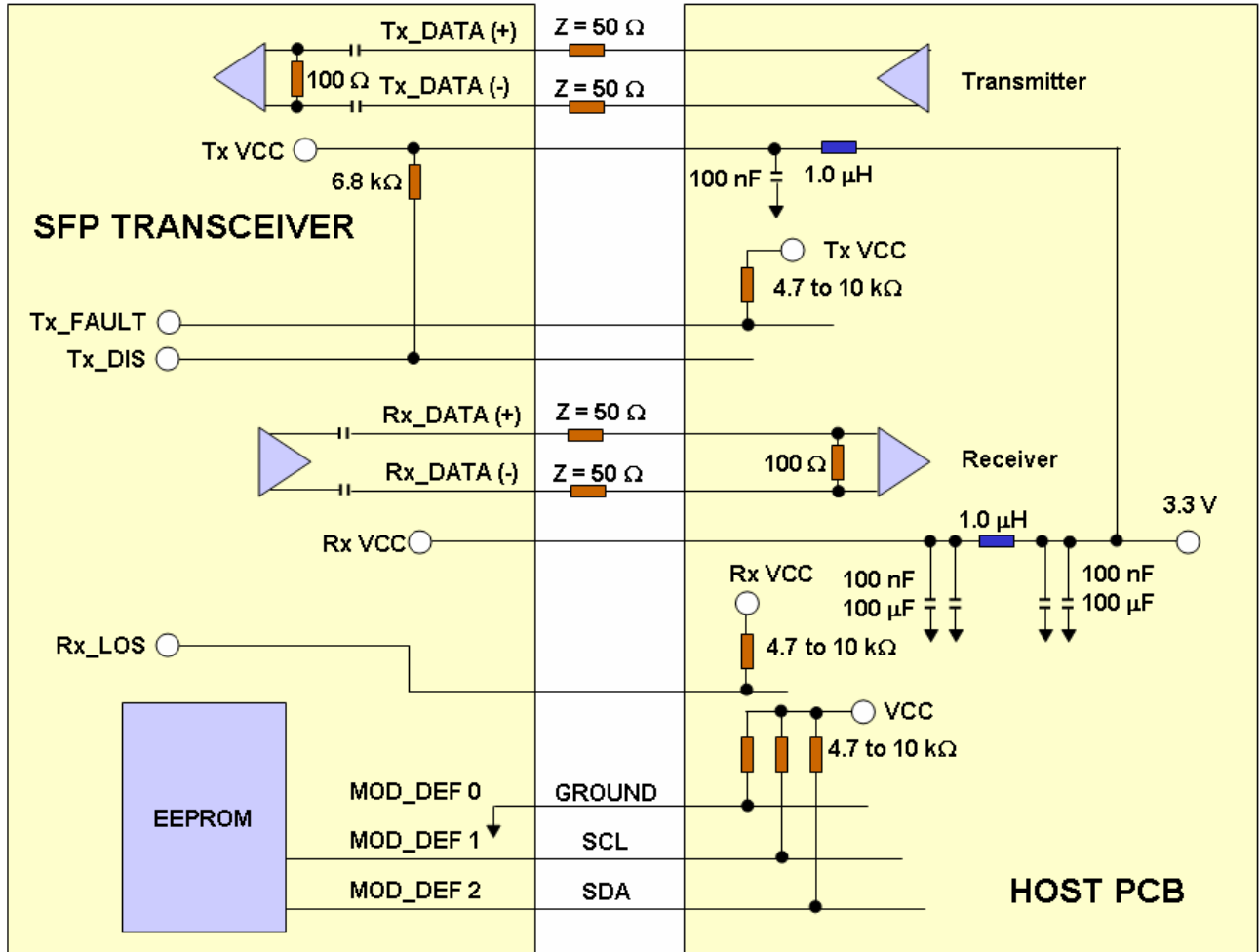



#### Recommended PCB Layout

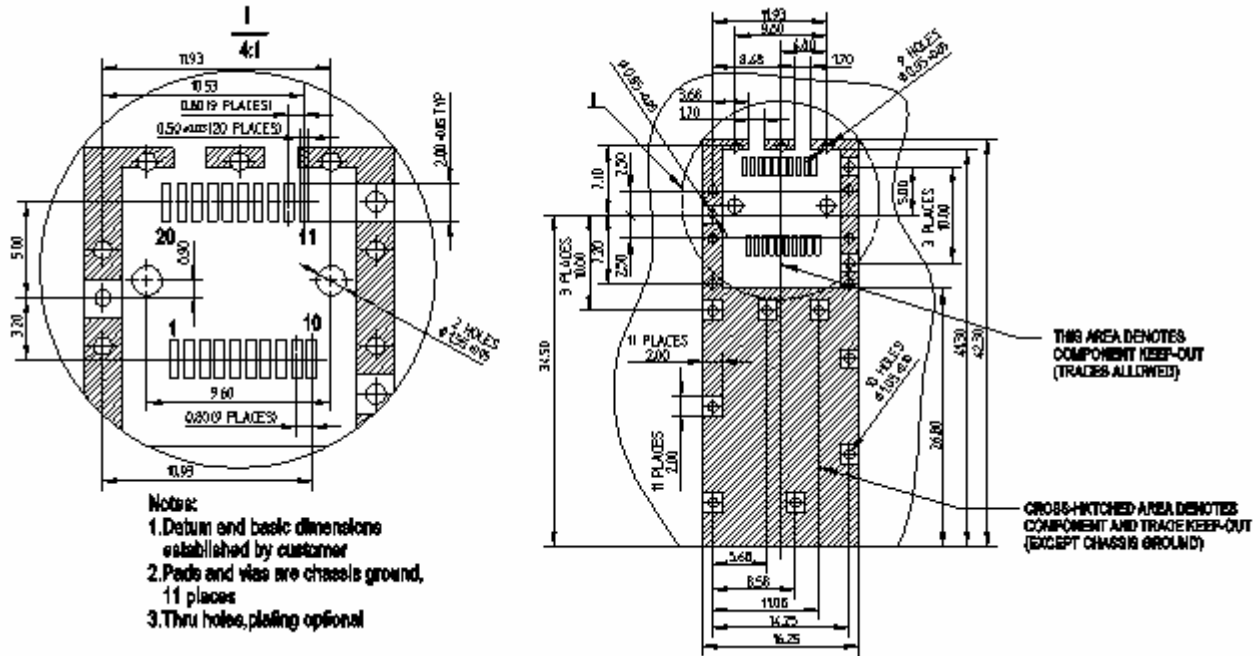

#### Recommended Front Panel Layout Opening for LC

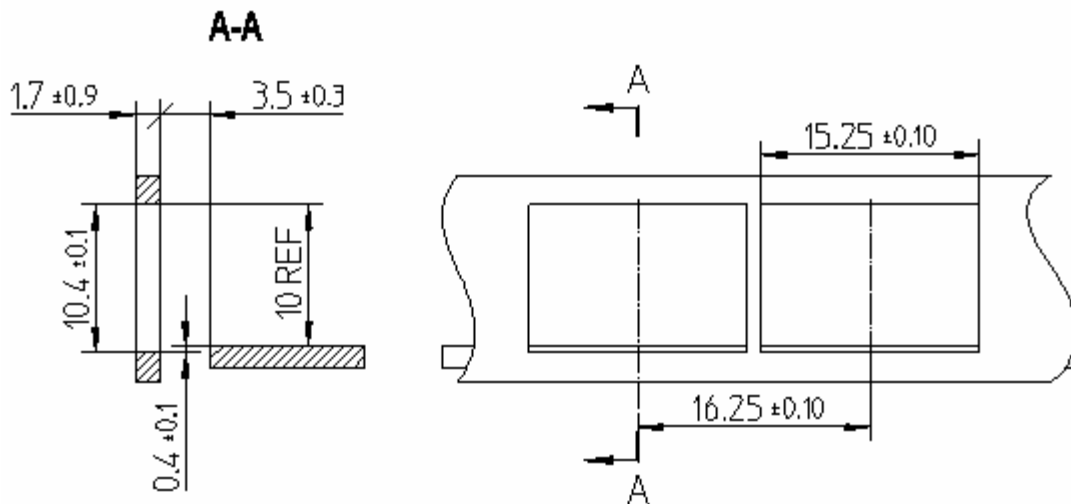



#### Mechanical Dimensions

Bail Latch

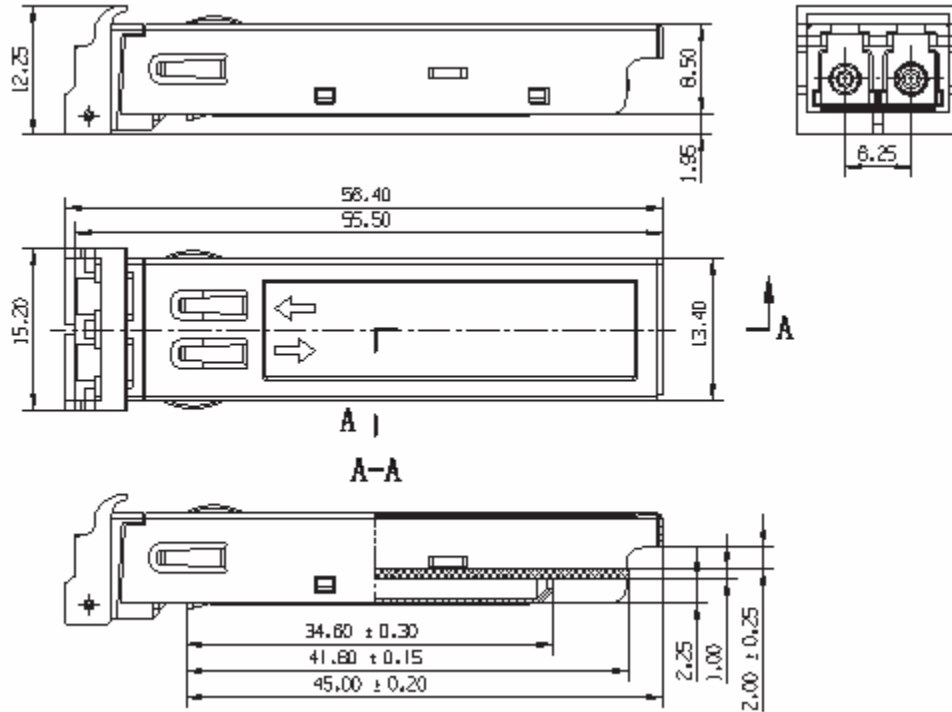

Pull Latch

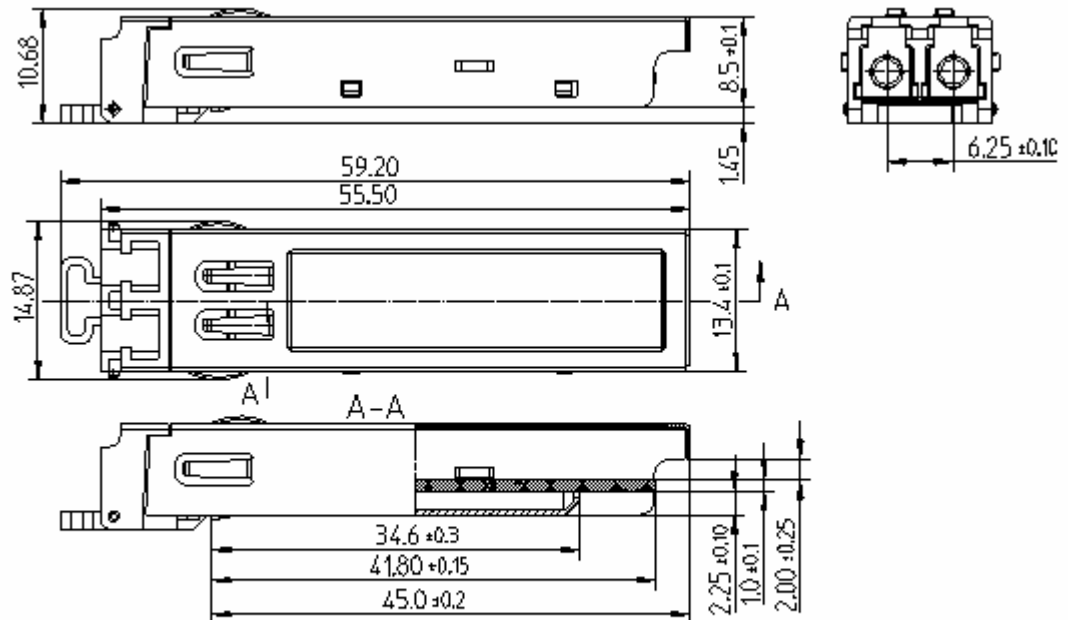

Dimensions are in millimeters  
 Dimension tolerance is ± 0.1mm unless otherwise specified



### Regulatory Information

#### Eye Safety

The transceiver is a Class 1 eye-safe device according to FDA 21CFR1040.10 and IEC 60825-1.

#### Electromagnetic Interference (EMI), Immunity and Product Safety

The transceiver is ESD safe (electrical pins) when tested according to MIL-STD-883, Method 3015.7 and ESD safe (optical connector) when tested according to IEC 61000-4-2. The device is immune to strong RF fields when tested in accordance with IEC 61000-4-3. The device complies with (US) FCC, Part 15, Subpart J; (Europe) CENELEC EN 55022; (Canada) Class B (CISPR22A); and (Japan) VCCI Class 1. The device has been designed to conform to product safety requirements including UL1950, CSA 22.2, and IEC 60950-1, and has been designed to meet the flammability requirements of UL94.

#### Notice

The factory has made all adjustments to this device prior to shipment. No adjustments or modifications to the device are required or permitted. Any adjustment, modification or tampering of the device voids the product warranty. The US Food and Drug Administration may consider that any adjustment or modification to this device is an act of manufacturing and therefore will require that the device be recertified in accordance with 21 CFR 1040.10 Subpart j.

#### Laser Radiation Information

Wavelength	1310 nm
FDA Total Pout: 7 mm aperture at 20 cm distance	< 195 microwatts
IEC Total Pout : 7 mm aperture at 10 cm distance	< 15,600 microwatts
Beam Divergence	17.25°

#### Required Label

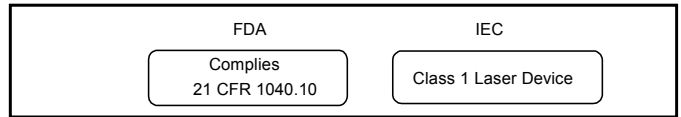

#### Laser Emission

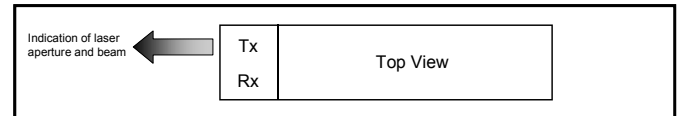

### Ligent Sales Offices - USA

#### Ligent Photonics, Inc.

2701 Dukane Drive  
Suite 200  
St. Charles, IL 60174  
PH (630) 513-7226  
FX (630) 513-9173  
WS www.ligentphotonics.com

#### Ligent Photonics, Inc.

(Virginia Sales Office)  
8210 Strathmore Lane  
Roanoke, VA 24019  
PH (540) 797-5793  
FX (540) 366-5793  
WS www.ligentphotonics.com

#### New Age Electronics

3000 Northwood's Parkway  
Suite 280  
Norcross, GA 30071  
PH (770) 242-8800  
FX (770) 242-8180  
WS www.newagelec.com

#### New Age Electronics

8376 Six Forks Road  
Suite 202  
Raleigh, NC 27615  
PH (919) 866-0620  
FX (919) 866-0621  
WS www.newagelec.com

#### New Age Electronics

4940 Corporate Drive  
Suite B  
Huntsville, AL 35805  
PH (256) 430-8000  
FX (256) 430-8414  
WS www.newagelec.co

#### K-Tech Sales

100 Century Center Court  
Suite 405  
San Jose, CA 95112  
PH (408) 437-1808  
FX (408) 437-1883  
WS www.ktechsales.com

#### Kruvand Associates

1202 Richardson Drive  
Suite 113  
Richardson, TX 75080  
PH (972) 437-3355  
FX (972) 680-8854  
WS www.kruvand.com

#### Kruvand Associates

8100 Shoal Creek Boulevard  
Suite 250  
Austin, TX 75080  
PH (512) 454-1111  
FX (512) 454-9858  
WS www.kruvand.com

#### Kruvand Associates

10601 Grant Road  
Suite 104  
Houston, TX 77070  
PH (713) 956-6741  
FX (713) 972-680-8854  
WS www.kruvand.com

#### VAL Technical Sales

183 Prospect Street  
Hingham, MA 02043  
PH (781) (781) 749-8358  
FX (781) 740-4663  
WS www.valtechnical.com

### Ligent Sales Offices - Asia

#### Hisense Optoelectronics Technology Co., Limited

No.11, Jiangxi Road  
Qingdao, Shandong  
China 266071  
PH 86 (532) 601-0000  
FX 86 (532) 601-6007  
WS www.hisenseopto.com

#### Summit Hisense Company, Limited

Triton Square  
Office Tower Z 19F 1-8-12  
Harumi Chuo-ku 104-6219  
Japan  
PH 81-3-5547-1252  
FX 81-3-5547-1268