

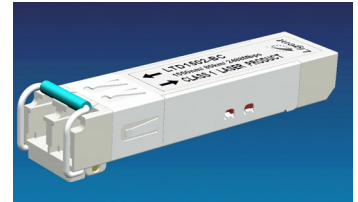

Ligent's LTD1325 SONET/SDH LC duplex transceiver is intended for 35 link budget service in 155 Mb/s 1310 nm single mode high-speed telecommunications equipment where low-cost, extraordinary performance and reliability are essential. It meets the requirements of Telcordia SONET OC-3/VR-2 and ITU-T G.957 SDH STM-1/V-1.2, consumes low power, operates from a 3.3 volt DC power supply and is offered in the 0 to 70°C commercial temperature range. The industry standard 2x10 small form pluggable (SFP) package is fabricated with a rugged die cast metal housing and cage assembly. The low jitter and low bit error rate optical assemblies features a 1310 nm DFB laser transmitter and PIN/TIA receiver. It incorporates the SFP MSA LVTTTL Loss of Signal (Rx\_LOS), Tx Fault (Tx\_FAULT) and Tx Disable (Tx\_DIS) monitor and control functions. The SFF-8472 Rev 9.3 compliant digital diagnostic monitor feature, which is accessed via the I<sup>2</sup>C 2-wire serial ID interface, is an available option. The differential AC coupled Tx and Rx data interfaces (50 ohms to ground, 100 ohms line to line) are LVPECL compatible. The device is Class I laser safety compliant.



#### APPLICATIONS

- 155Mb/s SONET/SDH telecom equipment
- Rack to rack system interconnects
- Metro / Access Networks
- Switch to switch interfaces
- Hub interconnects
- Bus extenders
- Channel extenders
- Host adapter interconnects
- Mass storage system interconnects
- Telecom switches
- Router interconnects

#### FEATURES

- LC duplex optical interface
- 35 dB Link Budget
- 155 Mb/s data rate
- +3.3 V power supply
- Low DC power consumption
- 2x10 SFP MSA compliant package
- Bail latch
- Hot swappable
- High performance 1310 nm DFB laser
- High sensitivity PIN/TIA optical receiver:
- Single Mode operation
- BER < 1X10<sup>-10</sup> (2<sup>23</sup> - 1 NRZ PRBS)
- Telcordia SONET OC-3 VR-2 compliant
- ITU-T G.957 SDH STM-1 V1.2 compliant
- 0 to +70°C operating temperature range
- Monitor and Control Functions
  - Loss of Signal (Rx\_LOS), LVTTTL
  - Tx Disable (Tx\_DIS), LVTTTL
  - Tx Fault (Tx\_FAULT), LVTTTL
  - 2-wire I<sup>2</sup>C data bus
  - SFF-8472 Rev 9.3 MSA compliant
- Internally AC coupled and terminated
- LVPECL Rx and Tx data interface
  - 100 Ohms differential (line to line)
  - 50 Ohms single ended (line to ground)

Ordering Information	
Latch Options	Bail   Latch is compatible with the dimensions defined by the SFP MSA
Case Operating Temperature	Commercial

Part Number	Latch Configuration (X)		Temperature Range (Y)	
<b>LTD1325 XY</b>	B	Bail	C	0 to 70 °C



### Absolute Maximum Ratings (EXCEEDING THESE RATINGS MAY CAUSE IRREVERSIBLE DAMAGE TO THE DEVICE)

Parameter	Symbol	Minimum	Maximum	Units
Storage Temperature	T <sub>stg</sub>	-40	+85	°C
Relative Humidity - Storage	RH <sub>s</sub>	0	95	%
Relative Humidity - Operating	RH <sub>o</sub>	0	85	%
DC Supply Voltage	V <sub>CC</sub>	0	3.6	V
Soldering Temperature	T <sub>slid</sub>	0	260	°C
Soldering Time Duration	t <sub>slid</sub>	0	10	seconds
Tx DATA	V <sub>in</sub>	0	V <sub>CC</sub> + 0.5	V

### Optical and Electrical Signal Absolute Maximum Ratings

Signal / Data Input Voltage (Tx_DATA )	V <sub>IN PK-PK</sub>	-	2.4	V
8472 Clock Signal (Standard Mode)	I <sub>CLOCK</sub>	100	-	kHz
8472 Clock Signal (Fast Mode)	I <sub>CLOCK</sub>	-	400	kHz
Rx Optical Input Power	P <sub>IN-MAX</sub>		3	dBm

### Logic State Absolute Maximum Ratings

Tx_DISABLE Logic HIGH State	Tx_DIS	-	V <sub>CC</sub> +0.5	V
Tx_FAULT Logic HIGH State	Tx_FAULT	-	V <sub>CC</sub> +0.5	V
Rx_LOS Logic HIGH State	Rx_LOS	-	V <sub>CC</sub> +0.5	V
8472 MOD-DEF2	MOD_DEF2	-	V <sub>CC</sub> +0.5	V

### Recommended Operating Conditions

Parameter	Symbol	Min	Typ	Max	Units	Notes
Case Operating Temperature	T <sub>amb</sub>	-5	25	+70	°C	Temperature Range = C
DC Supply Voltage	V <sub>CC</sub>	3.14	3.30	3.46	Volts	
Module Supply Current	I <sub>IN</sub>	-	150	220	mA	
Power Dissipation	P <sub>D</sub>	-	500	750	mW	



Transmitter Logic						
Parameter	Function	Logic State	Logic Type	Min	Max	Units
Tx_DIS and Tx_FAULT	DISABLE	HIGH	LVTTL	2.4	V <sub>CC</sub> +0.3	V
Tx_DIS and Tx_FAULT	ENABLE	LOW	LVTTL	0	0.8	V
Tx_DIS	Assert Time	-	LVTTL	-	10	µs
Receiver Logic						
Parameter	Function	Logic State	Logic Type	Min	Max	Units
Rx_LOS	LOSS OF SIGNAL	HIGH	LVTTL	2.4	V <sub>CC</sub> +0.3	V
Rx_LOS	NORMAL	LOW	LVTTL	0	0.8	V
I <sup>2</sup> C Serial ID Logic						
Parameter	Function	Logic State	Logic Type	Min	Max	Units
MOD_DEF 0	Digital Ground	Ground	N/A	0	0	V
MOD_DEF 1	Clock Signal	HIGH	LVTTL	2.4	V <sub>CC</sub> +0.3	V
		LOW	LVTTL	0	0.8	V
MOD_DEF 2	Serial Data	HIGH	LVTTL	2.4	V <sub>CC</sub> +0.3	V
		LOW	LVTTL	0	0.8	V

Transmitter Electro-Optical Characteristics						
Parameter	Symbol	LTD1325			Units	Notes
		Min	Typ	Max		
Laser Type		1310 nm DFB				
Optical Output Power	P <sub>o</sub>	0		+5	dBm	Average Optical Output
Center Wavelength	λ		1310		nm	
Spectral Line Width @ -20dB	Δλ	-	-	1	nm	
Side Mode Suppression Ratio	SMSR	30			dB	
Extinction Ratio	ER	10	-	-	dB	
Optical Rise and Fall Time	t <sub>r</sub> , t <sub>f</sub>	-	500	600	ps	20% - 80%
Relative Intensity Noise	RIN	-	-	-117	dB/Hz	
Transmitter Generated RMS Jitter	J <sub>RMS</sub>	-	-	0.007	UI	
Output Eye	ITU-T G.957 Compliant					
Tx Differential Input Impedance	Z <sub>in</sub>	-	100	-	Ohms	
Tx Differential Input Voltage	V <sub>IN</sub>	200	-	2400	mV p-p	LVPECL Tx DATA (Note 1)
Note 1: Internally AC coupled and terminated						



**Receiver Electro-Optical Characteristics**

Parameter	Symbol	LTD1325			Units	Notes
		Min	Typ	Max		
Receiver Type		PIN / TIA				
Receiver Optical Sensitivity (155Mb/s)	P <sub>IN</sub>	-	-	-35	dBm	Average Received Power (Note 1)
Receiver Optical Sensitivity (100Mb/s)	P <sub>IN</sub>	-	-	-35	dBm	Average Received Power (Note 1)
Receiver Optical Overload	P <sub>IN MAX</sub>	-	-	-8	dBm	
Center Wavelength	λ		1310		nm	
Optical Return Loss	RL	27	-	-	dB	
Rx Upper 3 dB Cutoff Frequency	f <sub>c</sub>	-	-	900	MHz	
Signal Loss - Assert	P <sub>SLA</sub>	-45	-	-36.5	dBm	
Signal Loss - Deassert	P <sub>S LD</sub>	-44.5	-	-36	dBm	
Signal Loss - Hysteresis	P <sub>H</sub>	0.5	2	5	dB	
Data Output Rise / Fall Time	t <sub>r</sub> / t <sub>f</sub>		500	-	ps	20 - 80 %
Rx Differential Load Impedance	Z <sub>LOAD</sub>	-	100	-	Ohms	
Rx Differential Output Voltage	V <sub>OUT</sub>	300	-	1800	mV p-p	LVPECL Rx DATA (Note 2)

Note 1: Average received power where the BER = 10<sup>-10</sup>, measured with a 2<sup>23</sup>-1 NRZ test pattern

Note 2: Internally AC coupled and terminated

**EYE DIAGRAM**

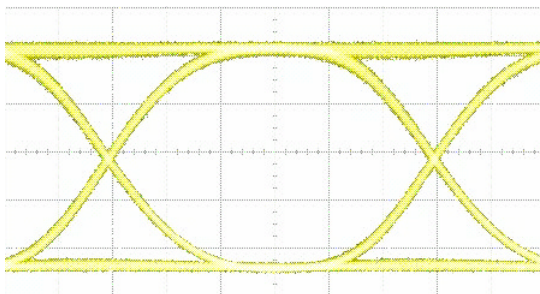

**Transmitter Test Conditions**

- Optical Output Power = **2 dBm**
- Test Pattern = 2<sup>23</sup>-1 NRZ PRBS

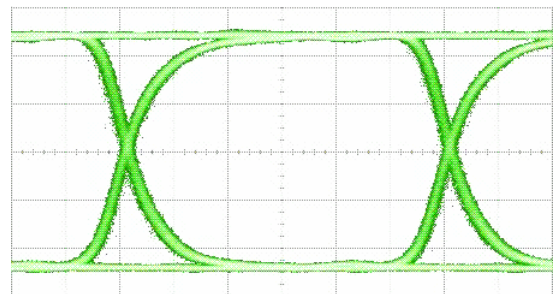

**Receiver Test Conditions**

- Optical Input Power = **-17 dBm**
- Test Pattern = 2<sup>23</sup>-1 NRZ PRBS



**TRANSCEIVER BLOCK DIAGRAM**

**Transmitter Section**

The transmitter section consists of a high reliability 1310nm DFB laser diode (LD) with back facet monitor photo detector (PD) in an eye safe optical sub-assembly (TOSA), which is mated to the Tx port of the fiber optic LC duplex receptacle. A driver IC converts LVPECL differential input data signals into an analog current source that drives the LD. The transmitter is provided with the Tx\_Disable and Tx\_FAULT control and monitoring functions. SFF-8472 Rev 9.3 MSA digital diagnostics are enabled via the 2-wire I<sup>2</sup>C data bus.

**Receiver Section**

The receiver section consists of a high-speed InGaAs PIN photodiode and transimpedance preamplifier mounted in an optical subassembly (ROSA), which is mated to the Rx port of the fiber optic LC duplex receptacle. The output of the PD drives the post-amplification, quantizing, and optical signal detection circuits. The receiver is equipped with the Rx\_LOS (Loss of Signal) monitoring function.

**MONITOR AND CONTROL FUNCTIONS**

**Rx Signal Loss (Rx\_LOS) Description**

The Rx\_LOS (Loss of Signal) is an open collector LVTTTL monitor port. It switches state based on the received optical input signal level that passes through the photo detector (PD), post amplifier and quantizer. If the received signal is above the Rx threshold, then Rx\_LOS is set LOW indicating normal operation. If the received signal is below the Rx threshold, then Rx\_LOS is set HIGH indicating a possible broken fiber, unplugged connector or low Tx signal from the host. The Rx\_LOS pin requires an external 4.7K to 10 K Ohm pull-up resistor.

**Tx Disable (Tx\_DIS) Description**

The Tx\_DIS (Transmit Disable) is an open collector LVTTTL control port that is controlled by a logic signal on the host (system) printed circuit board. If the system is ready to send data then the Tx\_DIS line

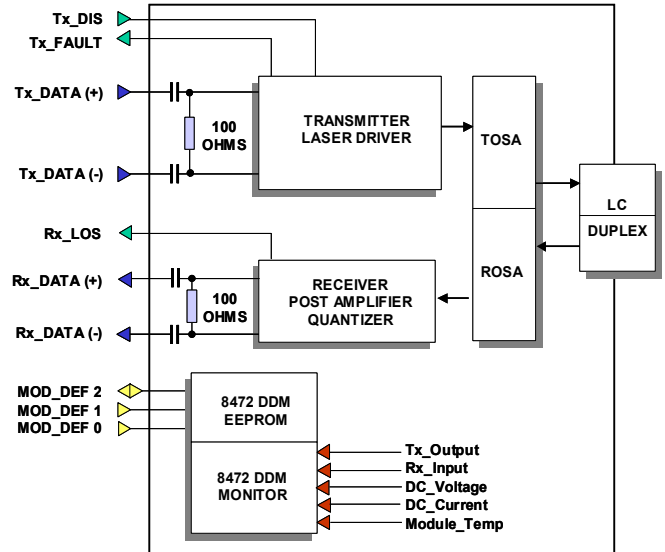

is set LOW to enable the laser driver and the laser transmitter. If the system is not ready to send data, then the Tx\_DIS line is set HIGH to disable the transmitter.

**Tx Fault (Tx\_FAULT) Description**

The Tx\_FAULT (Transmit Fault) is an open collector LVTTTL monitor port. It switches states based on the condition of the laser driver and the laser including the end of life condition of the laser. If the parameters of the laser driver and laser are within specifications then the Tx\_FAULT is set LOW indicating normal transceiver operation. If a fault occurs, including excess optical output power then Tx\_FAULT is set HIGH which disables the transmitter. The Tx\_FAULT can be reset to normal operation by toggling Tx\_DIS or switching the power supply. The Tx\_FAULT pin requires an external 4.7K to 10K Ohm pull-up resistor.



#### SFP MSA and SFF 8472 REVISION 9.3 DIGITAL DIAGNOSTICS

This device incorporates the SFF-8472 Revision 9.3 digital diagnostic monitoring and control functions, which provide backward compatibility with the SFP-MSA digital diagnostic interface.

This device incorporates two 128-bytes data tables:

1. Table A0 (HEX) contains 128-bytes of information relating to the type of device as shown in the table below. The data is programmed into memory at the time the device is manufactured and is normally WRITE PROTECTED.
2. Table A2 (HEX) contains 128-bytes of real-time dynamic data from the internal calibration of the device, which includes the module temperature, the transmit output power, the receiver input power, the module DC operating current and the DC oper-

ating voltage. At the time the device is manufactured upper and lower WARNING and ALARM limits are stored in the EEPROM and WRITE PROTECTED. During operation, the stored values are compared with the real time data generated by the transceiver and a FLAG is SET if the WARNING or ALARM values are exceeded.

The SFF-8472 Revision 9.3 digital diagnostic interface enables the system host to discover the transceiver's parametric and data functions via a 2-wire system with one wire providing the clock and timing information and the other wire providing two-way communications with the transceiver. Additional information can be found in the SFF-8472 Rev 9.3 documentation.

Code Table for 8472 Digital Diagnostics - Page A0 HEX

Data Address	No of Bytes	Name of Field	Field Description
0	1	ID Field	SFP transceiver
1	1	Extended ID Field	SFP function is defined by serial ID only
2	1	Connector ID Field	LC optical connector
6	1	Transceiver ID Field	OC-3 long reach
11	1	Transceiver Encoding	SONET Scrambled
12	1	Nominal Bit Rate	155 Mb/s
14	1	Link Length	35 dB Link Budget
15	1	Link Length > 25.4 km	GBIC compatibility requirement
20 to 35	16	Vendor Name	Ligent Photonics
37 to 39	3	Vendor IEEE ID	TBD
40 to 55	16	Ligent Part Number	LTD1325
56 to 59	4	Ligent Rev Number	1.2
60 to 61	2	Wavelength	1310 nm
65	1	SFP Codes	Rx LOS, Tx DIS, Tx FAULT
66, 67	1	Bit Rate Max Tolerance	20 percent
68 to 83	16	Ligent Serial Number	Loaded at time of manufacture
84 to 91	8	Ligent Date Code	Loaded at time of manufacture
92	1	Type of Diagnostics	Average Power, Internal Calibration, DDM
93	1	Enhanced Options	Alarm / Warning Flags, Soft Fault, LOS
94	1	8472 Compatibility	Compatible with 8472 Rev 9.3



#### PAGE A2 (HEX) SFF 8472 REVISION 9.3 DIGITAL DIAGNOSTICS

Page A2 (HEX) contains the ALARM, WARNING and ACTUAL data for 5 different transceiver parameters. The information is stored in the "two's-complement" format with the MSB occupying the lower byte and the LSB occupying the higher byte as shown in the table below. For each of the 5 parameters there are 10 memory locations:

1. High ALARM Value
2. Low ALARM Value
3. High WARNING Value
4. Low WARNING Values
5. Real Time Data

When an ALARM or WARNING value is reached, a FLAG is set that can be read by the I<sup>2</sup>C serial interface. The FLAG is a single bit in a specific 8-bit memory location. It is possible to have several ALARM and WARNING FLAGS set within a single 8-bit byte. In the table below, bytes 112, 113, 116 and 117 are the FLAG memory locations and the number in the parenthesis is the bit location with the 8-bit byte.

SFF-8472 Rev 9.3 A2 (HEX) Address Table for Alarm and Warning Data

8472 Parameter	Alarm Threshold Data				Warning Threshold Data				Measured Values		Alarm Bit (Set) Address + Position		Warning Bit (Set) Address + Position	
	High Value		Low Value		High Value		Low Value				High	Low	High	Low
	MSB	LSB	MSB	LSB	MSB	LSB	MSB	LSB	MSB	LSB	High	Low	High	Low
Temperature	00	01	02	03	04	05	06	07	96	97	112 (7)	112 (6)	116 (7)	116 (6)
Vcc	08	09	10	11	12	13	14	15	98	99	112 (5)	112 (4)	116 (5)	116 (4)
Tx Bias	16	17	18	19	20	21	22	23	100	101	112 (3)	112 (2)	116 (3)	116 (2)
Tx Out	24	25	26	27	28	29	30	31	102	103	112 (1)	112 (0)	116 (1)	116 (0)
Rx Input	32	33	34	35	36	37	38	39	104	105	113 (7)	113 (8)	117 (7)	117 (6)

#### REGULATORY INFORMATION

##### Eye Safety

The transceiver is a Class 1 eye-safe device according to FDA 21CFR1040.10 and IEC 60825-2.

##### Electromagnetic Interference (EMI), Immunity and Product Safety

The transceiver is ESD safe (electrical pins) when tested according to MIL-STD-883, Method 3015.7 and ESD safe (optical connector) when tested according to IEC 61000-4-2. The device is immune to strong RF fields when tested in accordance with IEC 61000-4-3. The device complies with (US) FCC, Part 15, Subpart J; (Europe) CENELEC EN 55022; (Canada) Class B (CISPR22A); and (Japan) VCCI Class 1. The device has been designed to conform to product safety require-

ments including UL1950, CSA 22.2, and IEC 60950-1, and has been designed to meet the flammability requirements of UL94.

##### Notice

The factory has made all adjustments to this device prior to shipment. No adjustments or modifications to the device are required or permitted. Any adjustment, modification or tampering of the device voids the product warranty. The US Food and Drug Administration may consider that any adjustment or modification to this device is an act of manufacturing and therefore will require that the device be recertified in accordance with 21 CFR 1040.10 Subpart j.



**PIN ASSIGNMENT**

20		VEET
19		TD-
18		TD+
17		VEET
16		VCCT
15		VCCR
14		VEER
13		RD+
12		RD-
11		VEER

1		VEET
2		Tx_FAULT
3		Tx_DIS
4		MOD_DEF 2
5		MOD_DEF 1
6		MOD_DEF 0
7		Rate Select
8		Rx_LOS
9		VEER
10		VEER

**Transceiver Electrical Pad Layout**  
Top View Bottom View

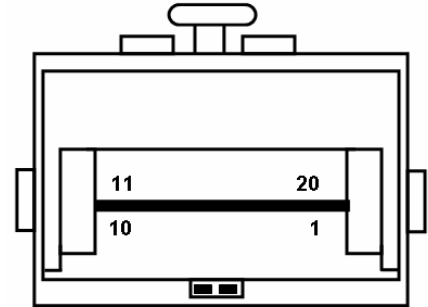

**Transceiver Pin Locations**

**SFP Pin Assignment**

Pin	Symbol	Logic Type	Description	Notes
1	V <sub>EET</sub>	N/A	Transmitter Ground	
2	Tx_FAULT	LVTTL	Transmitter Fault, LOW = Normal Operation, HIGH = Fault Indication	Note 1
3	Tx_DIS	LVTTL	Transmit Disable, LOW = Normal Operation, HIGH = Disables Module	Note 1
4	MOD_DEF 2	LVTTL	Module Definition 2 - Two-Wire Interface - Serial Data	Note 1
5	MOD_DEF 1	LVTTL	Module Definition 1 - Two-Wire Interface - Clock Signal	Note 1
6	MOD_DEF 0	LVTTL	Module Definition 0 - Two-Wire Interface Digital Ground	
7	Rate Select	N/A	Not Connected	
8	Rx_LOS	LVTTL	Receiver Loss of Signal, LOW = Normal Operation, HIGH = Loss of Signal	Note 1
9	V <sub>EER</sub>	N/A	Receiver Ground	
10	V <sub>EER</sub>	N/A	Receiver Ground	
11	V <sub>EER</sub>	N/A	Receiver Ground	
12	RD-	LVPECL	Rx_Data Output (Inverted)	Note 2
13	RD+	LCPECL	Rx_Data Output (Non Inverted)	Note 2
14	V <sub>EER</sub>	N/A	Receiver Ground	
15	V <sub>C</sub> CR	N/A	Receiver DC Power	3.3 V +/- 5%
16	V <sub>C</sub> CT	N/A	Transmitter DC Power	3.3 V +/- 5%
17	V <sub>EET</sub>	N/A	Transmitter Ground	
18	TD+	LVPECL	Tx_Data Input (Non Inverted)	Note 3
19	TD-	LVPECL	Tx_Data Input (Inverted)	Note 3
20	V <sub>EET</sub>	N/A	Transmitter Ground	

**Notes**

1. The uncommitted Tx\_Fault, Rx\_LOS, MOD\_DEF 1 and MOD\_DEF 2 LVTTL monitor and control pins each require a pull up resistor of 4.7K to 10K Ohms.
2. The 100 Ohm differential Rx Data output is internally AC coupled and must be terminated with 100 Ohms at the differential user interface.





**BAIL LATCH OUTLINE DRAWING**

(Dimensions are in Millimeters)

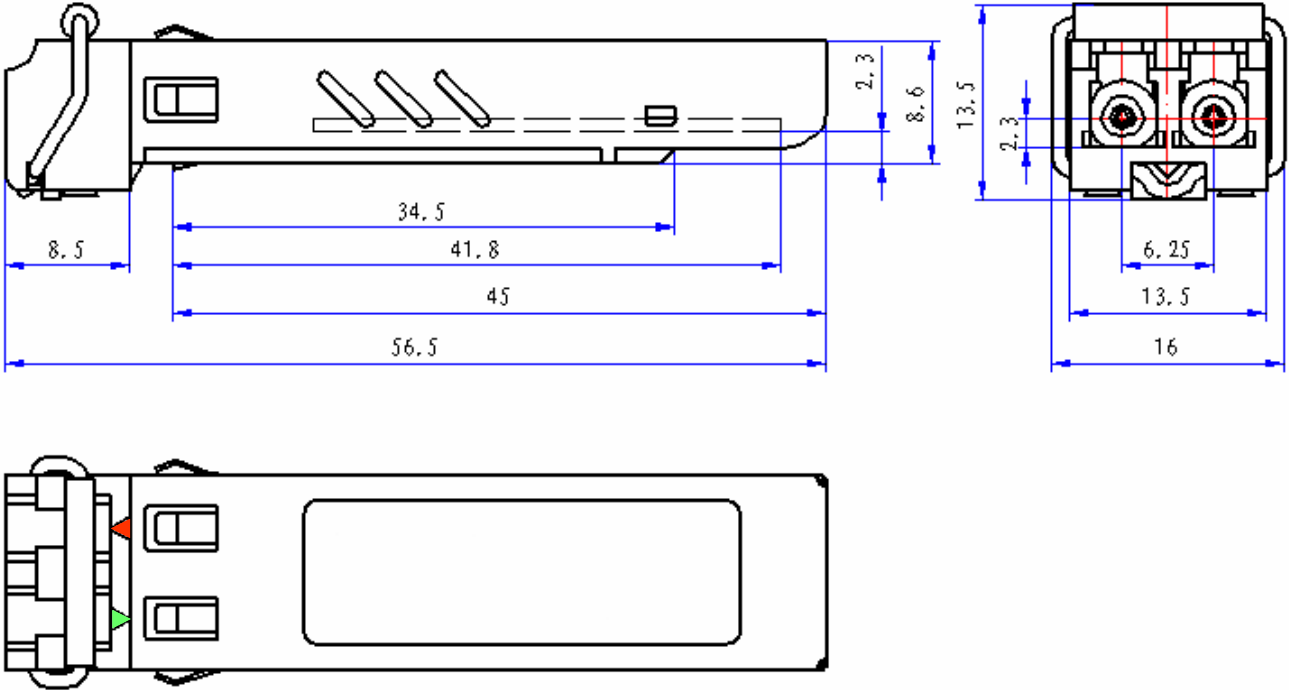

**RECOMMENDED INTERFACE CIRCUIT**



Regulatory Information		
Test Type	Industry Standard	Conditions
Eye Safety	CDRH / FDA 21CFR 1040.10	Class 1 Laser, Note 1 FDA Accession Number 0422608
	CDRH / FDA 21CFR 1040.11	
	IEC 60825-1	
Electrostatic Discharge to the Electrical Pins	MIL-STD-883, Method 3015.7	Contact Discharge, Level 2, 4 KV
	EIA / JESD22-A114-B	
Electrostatic Discharge to the LC Optical Connector	EN 61000-4-2	Air Discharge, Level 4, 15 KV
	IEC 61000-4-2	
EMI (Susceptibility to high RF fields)	EN 61000-4-3	Field Strength = 10 Volts / Meter Sweep Range = 10 MHz to 2 GHz
	IEC 61000-4-3	
Radiated RF Emission	FCC Part 15, Subpart J	Class B
	CISPR 22	
	EN55022, Class B	
Product Safety	UL94	Flammability

Note 1: The factory has made all adjustments to this device prior to shipment. No adjustments or modifications to the device are required or permitted. Any adjustment, modification or tampering of the device voids the product warranty. The US Food and Drug Administration may consider that any adjustment or modification to this device is an act of manufacturing and therefore will require that the device be recertified in accordance with 21 CFR 1040.10 Subpart j.

Laser Radiation Information	
Wavelength	1310 nm
FDA Total Pout: 7 mm aperture at 20 cm distance	< 790 microwatts
IEC Total Pout : 7 mm aperture at 10 cm distance	< 10,000 microwatts
Beam Divergence	17.25°

**REQUIRED LABEL**

**LASER EMISSION**