



The LTD1304 SFP SONET/SDH LC duplex transceiver is intended for 2 km reach service in 2.488 Gb/s 1310 nm single mode high-speed telecommunications equipment where low-cost, extraordinary performance and reliability are essential. It meets the requirements of Telcordia SONET OC-48/SR-1 and ITU-T G.957 SDH STM-16/I-16, consumes low power, operates from a 3.3 volt DC power supply and is offered in the commercial, extended and industrial temperature ranges. The industry standard 2x10 small form pluggable (SFP) package is fabricated with a rugged die cast metal housing and cage assembly. The low jitter and low bit error rate optical assemblies features a 1310 nm FP laser transmitter and PIN/TIA receiver. It incorporates the SFP MSA LVTTTL Loss of Signal (Rx_LOS), Tx Fault (Tx_FAULT) and Tx Disable (Tx_DIS) monitor and control functions and the SFF-8472 Rev 9.3 compliant digital diagnostic monitor feature which is accessed via the I²C 2-wire serial ID interface (MOD_DEF 0-1-2). The differential AC coupled Tx and Rx data interfaces (50 ohms to ground, 100 ohms line to line) are LVPECL compatible. The device is Class I laser safety compliant.



Applications

- 2488 Mb/s SONET/SDH telecom equipment
- Hub interconnects
- Mass storage system interconnects
- Rack to rack system interconnects
- Bus extenders
- Telecom switches
- Metro / Access Networks
- Channel extenders
- Router interconnects
- Switch to switch interfaces
- Host adapter interconnects

Features

- LC Duplex optical interface
- Telcordia SONET OC-48/SR-1 compliant
- Internally AC coupled and terminated
- 2 km reach
- ITU-T G.957 SDH STM-16/I-16 compliant
- LVPECL Rx and Tx data interface
- 2488 Mb/s data rate
- Operating temperature range:
 - Commercial: 0 to 70°C
 - 100 Ohms differential (line to line)
 - 50 Ohms single ended (line to ground)
 - Extended: -10 to 80°C
 - Industrial: -40 to 85°C
- +3.3 V power supply
- Monitor and Control Functions
 - Loss of Signal (Rx_LOS), LVTTTL
 - Tx Disable (Tx_DIS), LVTTTL
 - Tx Fault (Tx_FAULT), LVTTTL
- Low DC power consumption
- 2-wire I²C data bus
- 2x10 SFP MSA compliant package
- SFF-8472 Rev 9.3 MSA compliant
- Bail or pull latch option
- Hot swappable
- High performance 1310 nm FP laser
- High sensitivity PIN/TIA optical receiver:
- Single Mode operation
- BER < 1X10⁻¹⁰ (2²³- 1 NRZ PRBS)



Absolute Maximum Ratings (EXCEEDING THESE RATINGS MAY CAUSE IRREVERSIBLE DAMAGE TO THE DEVICE)

Parameter	Symbol	Minimum	Maximum	Units
Storage Temperature	T _{stg}	-40	+85	°C
Relative Humidity - Storage	RH _S	0	95	%
Relative Humidity - Operating	RH _O	0	85	%
DC Supply Voltage	V _{CC}	0	3.6	V
Soldering Temperature	T _{slid}	0	260	°C
Soldering Time Duration	t _{slid}	0	10	seconds
Tx DATA	V _{in}	0	V _{CC} + 0.5	V

Optical and Electrical Singal Absolute Maximum Ratings

Signal / Data Input Voltage (Tx_DATA)	V _{IN PK-PK}	-	2.4	V
8472 Clock Signal (Standard Mode)	I _{CLOCK}	100	-	kHz
8472 Clock Signal (Fast Mode)	I _{CLOCK}	-	400	kHz
Rx Optical Input Power	P _{IN-MAX}		3	dBm

Logic State Absolute Maximum Ratings

Tx_DISABLE Logic HIGH State	Tx_DIS	-	V _{CC} +0.5	V
Tx_FAULT Logic HIGH State	Tx_FAULT	-	V _{CC} +0.5	V
Rx_LOS Logic HIGH State	Rx_LOS	-	V _{CC} +0.5	V
8472 MOD-DEF2	MOD_DEF2	-	V _{CC} +0.5	V

Recommended Operating Conditions

Parameter	Symbol	Min	Typ	Max	Units	Notes
Ambient Operating Temperature	T _{amb}	0	25	+70	°C	Temperature Range = C
		-10	25	+80	°C	Temperature Range = E
		-40	25	+85	°C	Temperature Range = H
DC Supply Voltage	V _{CC}	3.14	3.30	3.46	Volts	
Module Supply Current	I _{IN}	-	130	180	mA	
Power Dissipation	P _D	-	450	700	mW	

Ordering Information

Latch Options	Bail and Pull Latches are compatible with the dimensions defined by the SFP MSA
Ambient Operating Temperature	Commercial, Extended or Industrial

Part Number	Latch Option (X)		Temperature Option (Y)	
LTD1304 XY	B	Bail	C	0 to 70 °C
	P	Pull	E	-10 to 80 °C
			H	-40 to 85 °C



Transmitter Logic						
Parameter	Function	Logic State	Logic Type	Min	Max	Units
Tx_DIS and Tx_FAULT	DISABLE	HIGH	LVTTL	2.4	V _{CC} +0.3	V
Tx_DIS and Tx_FAULT	ENABLE	LOW	LVTTL	0	0.8	V
Tx_DIS	Assert Time	-	LVTTL	-	10	µs
Receiver Logic						
Parameter	Function	Logic State	Logic Type	Min	Max	Units
Rx_LOS	LOSS OF SIGNAL	HIGH	LVTTL	2.4	V _{CC} +0.3	V
Rx_LOS	NORMAL	LOW	LVTTL	0	0.8	V
I ² C Serial ID Logic						
Parameter	Function	Logic State	Logic Type	Min	Max	Units
MOD_DEF 0	Digital Ground	Ground	N/A	0	0	V
MOD_DEF 1	Clock Signal	HIGH	LVTTL	2.4	V _{CC} +0.3	V
		LOW	LVTTL	0	0.8	V
MOD_DEF 2	Serial Data	HIGH	LVTTL	2.4	V _{CC} +0.3	V
		LOW	LVTTL	0	0.8	V

Transmitter Electro-Optical Characteristics						
Parameter	Symbol	LTD1304			Units	Notes
		Min	Typ	Max		
Laser Type		1310 nm F-P				
Optical Output Power	P _o	-10		-3	dBm	Average Optical Output
Center Wavelength	λ	1270	1310	1360	nm	
RMS Spectral Line Width	Δλ	-	4	-	nm	
Extinction Ratio	ER	8.2	-	-	dB	
Optical Rise and Fall Time	t _r , t _f	-	150	160	ps	20% - 80%
Relative Intensity Noise	RIN	-	-	-117	dB/Hz	
Transmitter Generated	DJ	-	-	0.21	UI	
RMS Jitter	J _{RMS}	-	-	0.007	UI	
Output Eye		ITU-T G.957 Compliant				
Tx Differential Input Impedance	Z _{in}	-	100	-	Ohms	
Tx Differential Input Voltage	V _{IN}	400	-	2400	mV p-p	LVPECL Tx DATA (Note 1)
Note 1: Internally AC coupled and terminated						



Receiver Electro-Optical Characteristics

Parameter	Symbol	LTD1304			Units	Notes
		Min	Typ	Max		
Package Type		SFP				
Signaling Rate		2.488			Gb/s	±100 ppm
Receiver Type		PIN / TIA				
Receiver Optical Sensitivity	P _{IN}	-	-	-18	dBm	Average Received Power (Note 1)
Receiver Optical Overload	P _{IN MAX}	-	-	-3	dBm	
Center Wavelength	λ	1260	1310	1360	nm	
Optical Return Loss	RL	12	-	-	dB	
Rx Upper 3 dB Cutoff Frequency	f _c	-	-	1500	MHz	
Signal Loss - Assert	P _{SLA}	-27	-	-20	dBm	
Signal Loss - Deassert	P _{SLD}	-27.5	-	-20.5	dBm	
Signal Loss - Hysteresis	P _H	0.5	2	5	dB	
Data Output Rise / Fall Time	t _r / t _f		150	-	ps	20 - 80 %
Rx Differential Load Impedance	Z _{LOAD}	-	100	-	Ohms	
Rx Differential Output Voltage	V _{OUT}	600	-	1800	mV p-p	LVPECL Rx DATA (Note 2)

Note 1: Average received power where the BER = 10⁻¹⁰, measured with a 2²³-1 NRZ test pattern

Note 2: Internally AC coupled and terminated

EYE DIAGRAM

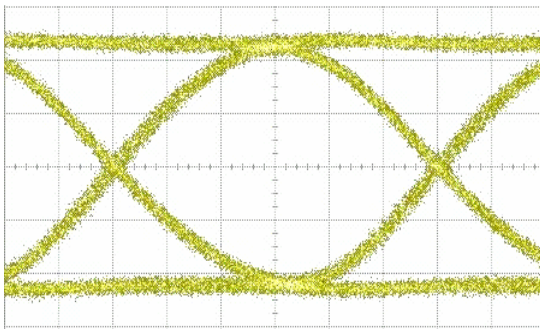

Transmitter Test Conditions

- Optical Output Power = **-5 dBm**
- Test Pattern = 2²³-1 NRZ PRBS

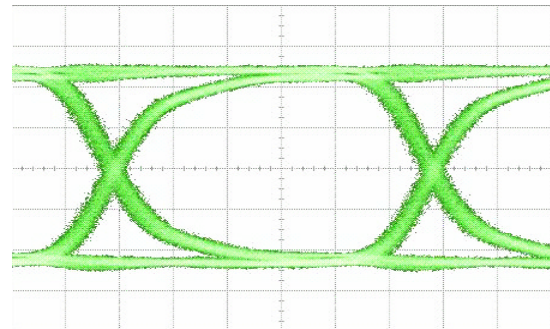

Receiver Test Conditions

- Optical Input Power = **-17 dBm**
- Test Pattern = 2²³-1 NRZ PRBS



Transceiver Block Diagram

Transmitter Section

The transmitter section consists of a high reliability 1310 nm F-P laser diode (LD) with back facet monitor photo detector (PD) in an eye safe optical sub-assembly (TOSA), which is mated to the Tx port of the fiber optic LC duplex receptacle. A driver IC converts LVPECL differential input data signals into an analog current source that drives the LD. The transmitter is provided with the Tx_Disable and Tx_FAULT control and monitoring functions. SFF-8472 Rev 9.3 MSA digital diagnostics are enabled via the 2-wire I2C data bus.

Receiver Section

The receiver section consists of a high-speed InGaAs PIN photodiode and transimpedance preamplifier mounted in an optical subassembly (ROSA), which is mated to the Rx port of the fiber optic LC duplex receptacle. The output of the PD drives the post-amplification, quantizing, and optical signal detection circuits. The receiver is equipped with the Rx_LOS (Loss of Signal) monitoring function.

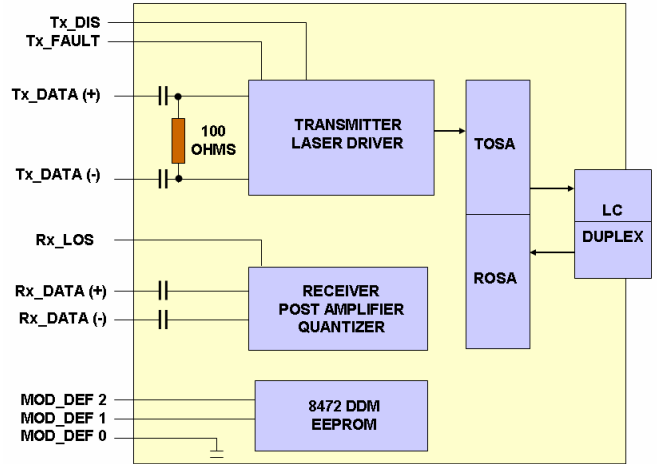

Transceiver Monitor and Control Functions

Rx Signal Loss (Rx_LOS) Description

The Rx_LOS (Loss of Signal) is an open collector LVTTTL monitor port. It switches state based on the received optical input signal level that passes through the photo detector (PD), post amplifier and quantizer. If the received signal is above the Rx threshold, then Rx_LOS is set LOW indicating normal operation. If the received signal is below the Rx threshold, then Rx_LOS is set HIGH indicating a possible broken fiber, unplugged connector or low Tx signal from the host. The Rx_LOS pin requires an external 4.7K to 10 K Ohm pull-up resistor.

Tx Disable (Tx_DIS) Description

The Tx_DIS (Transmit Disable) is an open collector LVTTTL control port that is controlled by a logic signal on the host (system) printed circuit board. If the system is ready to send data then the Tx_DIS line is set LOW to enable the laser driver and the laser transmitter. If the system is not ready to send data, then the Tx_DIS line is set HIGH to disable the transmitter.

Tx Fault (Tx_FAULT) Description

The Tx_FAULT (Transmit Fault) is an open collector LVTTTL monitor port. It switches states based on the condition of the laser driver and the laser including the end of life condition of the laser. If the parameters of the laser driver and laser are within specifications then the Tx_FAULT is set LOW indicating normal transceiver operation. If a fault occurs, including excess optical output power then Tx_FAULT is set HIGH, which disables the transmitter. The Tx_FAULT can be reset to normal operation by toggling Tx_DIS or switching the power supply. The Tx_FAULT pin requires an external 4.7K to 10K Ohm pull-up resistor.



SFP MSA and SFF 8472 Rev 9.3 Digital Diagnostics

This device incorporates the SFF-8472 Revision 9.3 digital diagnostic monitoring (DDM) feature, which is backward compatible with the original industry standard SFP MSA digital diagnostics. The device monitors 5 transceiver functions in real time and compares the measured data with the Alarm and Warning values stored in the internally calibrated 8472 DDM EEPROM. The DDM supports two "pages" of digital data:

- 1. Page A0 (HEX) contains the SFP MSA legacy data and,
2. Page A2 (HEX) contains the 8472 DDM data.

Flags are set by the DDM if the minimum or maximum Alarm or Warning values are exceeded. The DDM is accessed by the I2C two-wire data bus:

- 1. MOD_DEF 1 is the serial clock (SCL)
2. MOD_DEF 2 is the bidirectional (READ/WRITE) data port (SDA)

All memory locations can be READ via the I2C data port whereas only selected memory locations can be WRITTEN to via the I2C data bus. Additional information regarding READ/WRITE access and the details of the contents of each address is contained in the SFF-8472 Revision 9.3 documentation.

Table with 1 column and 1 row: 8472 DDM Memory Contents Page A0 (HEX) SFP MSA DDM Data. Contents include Transceiver Type, Transceiver Identifiers, Connector Types, Optical or Electrical Device, Encoding Type Supported, Nominal Bit Rate, Supported Link Length, Vendor Name, IEEE Vendor Code, Vendor Part Number, Vendor Revision Number, Laser Wavelength, Supported Diagnostics (Electrical), Upper and Lower Bit Rate Tolerance, Vendor Serial Number, Vendor Data Code, Supported Diagnostics (Software), 8472 Flag, Vendor Specific Memory.

Table with 1 column and 1 row: 8472 DDM Memory Contents Page A2 (HEX) 8472 DDM Data. Contents include Temperature Alarm (High and Low Values), Temperature Warning (High and Low Values), Vcc Alarm (High and Low Values), Vcc Warning (High and Low Values), Laser Bias Alarm (High and Low Values), Laser Bias Warning (High and Low Values), Tx Optical Output Alarm (High and Low Values), Tx Optical Output Warning (High and Low Values), Rx Optical Input Alarm (High and Low Values), Rx Optical Input Warning (High and Low Values), Real Time Measured Data (Signed Two's Complement, LSB, MSB), Alarm and Warning Flags for Each Parameter, Vendor Specific Memory.



PIN ASSIGNMENT

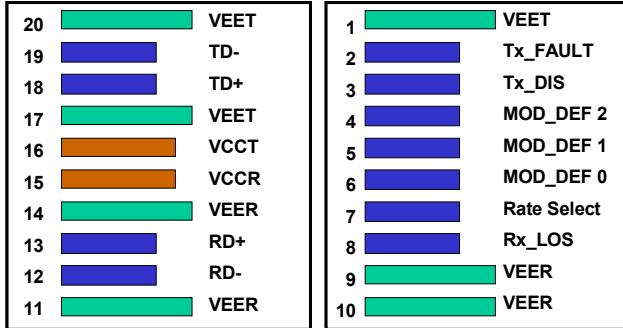

Transceiver Electrical Pad Layout
Top View **Bottom View**

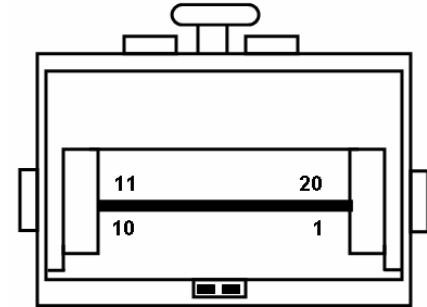

Transceiver Pin Locations

SFP Pin Assignment

Pin	Symbol	Logic Type	Description	Notes
1	V _{EET}	N/A	Transmitter Ground	
2	TX_FAULT	LVTTTL	Transmitter Fault, LOW = Normal Operation, HIGH = Fault Indication	Note 1
3	TX_DIS	LVTTTL	Transmit Disable, LOW = Normal Operation, HIGH = Disables Module	Note 1
4	MOD_DEF 2	LVTTTL	Module Definition 2 - Two-Wire Interface - Serial Data	Note 1
5	MOD_DEF 1	LVTTTL	Module Definition 1 - Two-Wire Interface - Clock Signal	Note 1
6	MOD_DEF 0	LVTTTL	Module Definition 0 - Two-Wire Interface Digital Ground	
7	Rate Select	N/A	Not Connected	
8	RX_LOS	LVTTTL	Receiver Loss of Signal, LOW = Normal Operation, HIGH = Loss of Signal	Note 1
9	V _{EER}	N/A	Receiver Ground	
10	V _{EER}	N/A	Receiver Ground	
11	V _{EER}	N/A	Receiver Ground	
12	RD-	LVPECL	RX_Data Output (Inverted)	Note 2
13	RD+	LCPECL	RX_Data Output (Non Inverted)	Note 2
14	V _{EER}	N/A	Receiver Ground	
15	V _C CR	N/A	Receiver DC Power	3.3 V +/- 5%
16	V _C CT	N/A	Transmitter DC Power	3.3 V +/- 5%
17	V _{EET}	N/A	Transmitter Ground	
18	TD+	LVPECL	TX_Data Input (Non Inverted)	Note 3
19	TD-	LVPECL	TX_Data Input (Inverted)	Note 3
20	V _{EET}	N/A	Transmitter Ground	

Notes

1. The uncommitted TX_Fault, RX_LOS, MOD_DEF 1 and MOD_DEF 2 LVTTTL monitor and control pins each require a pull up resistor of 4.7K to 10K Ohms
2. The 100 Ohm differential RX Data output is internally AC coupled and must be terminated with 100 Ohms at the differential user interface.
3. The 100 Ohm differential TX Data input is internally AC coupled and terminated.



Outline Drawing (Bail Latch)

(Dimensions are in Millimeters)

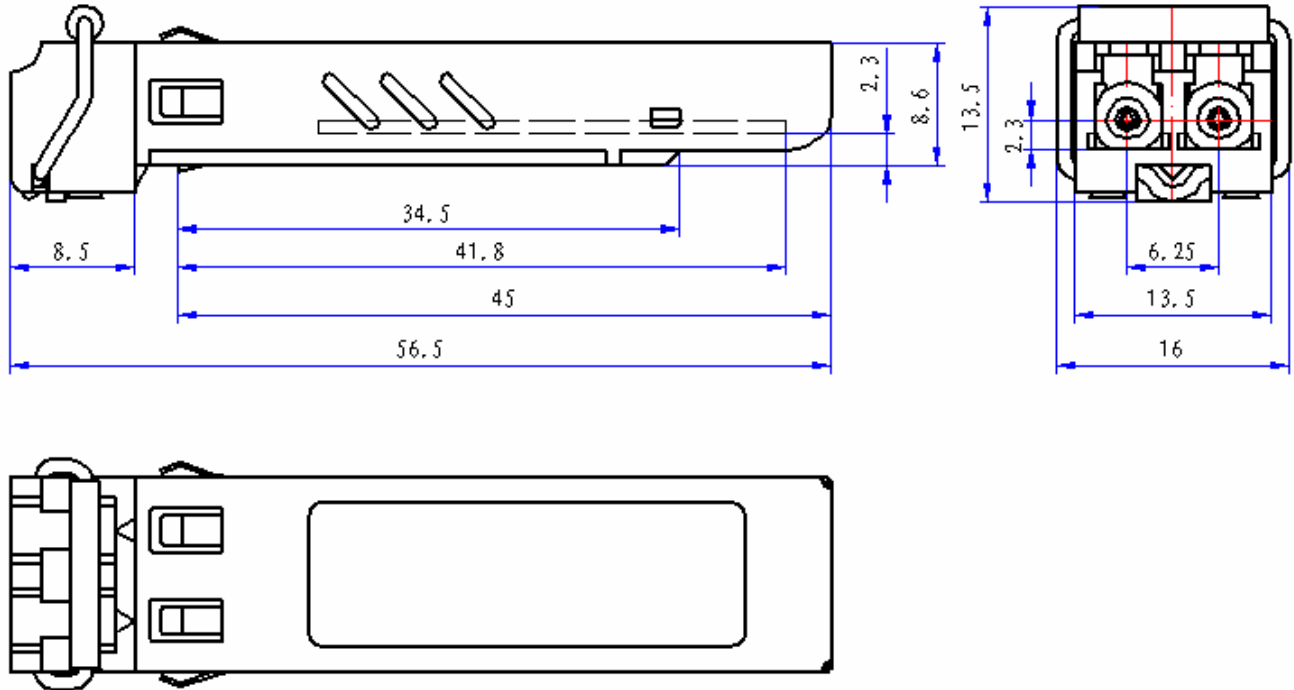

Recommended Interface Circuit

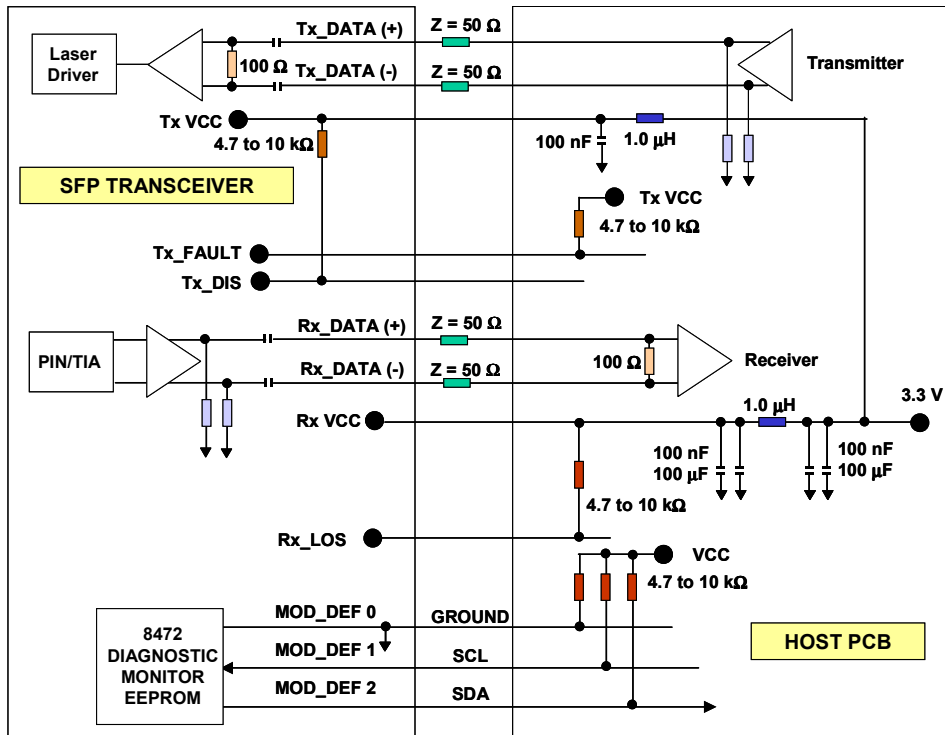



Regulatory Information		
Test Type	Industry Standard	Conditions
Eye Safety	CDRH / FDA 21CFR 1040.10	Class 1 Laser, Note 1 FDA Accession Number 0422608
	CDRH / FDA 21CFR 1040.11	
	IEC 60825-1	
Electrostatic Discharge to the Electrical Pins	MIL-STD-883, Method 3015.7	Contact Discharge, Level 2, 4 KV
	EIA / JESD22-A114-B	
Electrostatic Discharge to the LC Optical Connector	EN 61000-4-2	Air Discharge, Level 4, 15 KV
	IEC 61000-4-2	
EMI (Susceptibility to high RF fields)	EN 61000-4-3	Field Strength = 10 Volts / Meter Sweep Range = 10 MHz to 2 GHz
	IEC 61000-4-3	
Radiated RF Emission	FCC Part 15, Subpart J	Class B
	CISPR 22	
	EN55022, Class B	
Product Safety	UL94	Flammability

Note 1: The factory has made all adjustments to this device prior to shipment. No adjustments or modifications to the device are required or permitted. Any adjustment, modification or tampering of the device voids the product warranty. The US Food and Drug Administration may consider that any adjustment or modification to this device is an act of manufacturing and therefore will require that the device be recertified in accordance with 21 CFR 1040.10 Subpart j.

Laser Radiation Information	
Wavelength	1310 nm
FDA Total Pout: 7 mm aperture at 20 cm distance	< 195 microwatts
IEC Total Pout : 7 mm aperture at 10 cm distance	< 15,600 microwatts
Beam Divergence	17.25°

Required Label

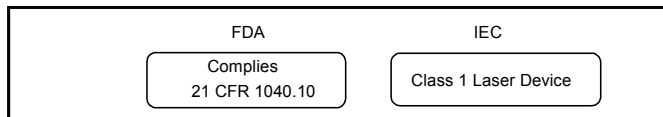

Laser Emission

