



The LTC1316 LC duplex transceiver is intended for 2 km reach service in SONET OC-3/SDH STM-1, and Fast Ethernet 1300 nm multimode LAN and SAN data communications equipment where low-cost, extraordinary performance and reliability is essential. It meets the requirements of the IEEE802.3u for 100Base-FX; the UNI SONET OC-3 multimode fiber physical layer specification and the FDDI PMD standard. It consumes low power, operates from a 3.3 volt DC power supply and is offered in the commercial, extended and industrial temperature ranges. The industry standard 2x5 small form factor (SFF) package is fabricated with a rugged die cast metal housing and cage assembly. The low jitter and low bit error rate optical assembly features a 1300 nm LED transmitter and PIN/TIA receiver. It incorporates the SFF MSA Rx\_Signal Detect (Rx\_SD) and Tx Disable (Tx\_DIS) monitor and control functions. The differential AC coupled Tx and Rx data interfaces are LVPECL compatible. The Rx Signal Detect function is offered with either the LVPECL or LVTTTL interface. The device is Class I laser safety compliant.



### Applications

- SONET/SDH equipment interconnect, SONET OC-3/SDH STM-1 rate
- Fast Ethernet
- FDDI
- Multimode fiber ATM backbone links

### Features

- LC Duplex optical interface
- 2 km reach
- Up to 155Mb/s data rate
- +3.3 V power supply
- Low DC power consumption
- 2x5 SFF MSA compliant package
- High performance 1300 nm LED
- High sensitivity PIN/TIA optical receiver:
- Multi Mode Fiber operation
- BER <  $1 \times 10^{-10}$  ( $2^{23}$  - 1 NRZ PRBS )
- Operating temperature range options:
  - Commercial: 0°C to 70°C
  - Extended: -10°C to +80°C
  - Industrial: -40 to 85°C
- Monitor and Control Functions
  - Signal Detect (Rx\_SD), LVTTTL
  - Signal Detect (Rx\_SD), LVPECL
  - Tx Disable (Tx\_DIS), LVTTTL
- Tx\_DATA signal interface
  - Differential LVPECL
  - AC-coupled and terminated
- Rx\_DATA signal interface
  - Differential LVPECL
  - AC-coupled



Absolute Maximum Ratings						
Parameter	Symbol	Min	Max	Units	Notes	
Storage Temperature	T <sub>stg</sub>	-40	+85	°C		
Relative Humidity - Storage	RH <sub>S</sub>	0	95	%		
Relative Humidity - Operating	RH <sub>O</sub>	0	85	%		
DC Supply Voltage	V <sub>CC</sub>	0	3.6	V		
Soldering Temperature	T <sub>slid</sub>	0	260	°C		
Soldering Time Duration	t <sub>slid</sub>	0	10	seconds		
Optical and Electrical Signal Absolute Maximum Ratings						
Signal / Data Input Voltage (Tx_DATA)	V <sub>IN PK-PK</sub>	0.3	2.4	V pk-pk		
Rx Optical Input Power	P <sub>IN-MAX</sub>	-	0	dBm		
Logic State Absolute Maximum Ratings						
Tx_DISABLE Logic HIGH State	Tx_DIS	-	V <sub>CC</sub> + 0.5	V		
Rx_SD Logic HIGH State	Rx_SD	-	V <sub>CC</sub> + 0.5	V	LVPECL or LVTTTL option	
Recommended Operating Conditions						
Parameter	Symbol	Min	Typ	Max	Units	Notes
Ambient Operating Temperature	T <sub>amb</sub>	0	25	+70	°C	Temperature Range = C
	T <sub>amb</sub>	-10	25	+80	°C	Temperature Range = E
	T <sub>amb</sub>	-40	25	+85	°C	Temperature Range = H
DC Supply Voltage	V <sub>CC</sub>	3.14	3.30	3.46	Volts	
Module Supply Current	I <sub>IN</sub>	-	200	300	mA	
Power Dissipation	P <sub>D</sub>	-	660	990	mW	

## HOW TO ORDER

Part Number	Lambda	Reach	Mode	Emitter	Optical Output	Receiver Sensitivity	Rx SD	Temperature Option	
<b>LTC1316 TC</b>	1300 nm	2 km	Multi Mode	LED	-22 to -12 dBm	-30 dBm	LVTTTL	C	0°C to 70°C
<b>LTC1316 TE</b>	1300 nm	2 km	Multi Mode	LED	-22 to -12 dBm	-30 dBm	LVTTTL	E	-10°C to +80°C
<b>LTC1316 TH</b>	1300 nm	2 km	Multi Mode	LED	-22 to -12 dBm	-30 dBm	LVTTTL	H	-40°C to +85°C
<b>LTC1316 C</b>	1300 nm	2 km	Multi Mode	LED	-22 to -12 dBm	-30 dBm	LVPECL	C	0°C to 70°C
<b>LTC1316 E</b>	1300 nm	2 km	Multi Mode	LED	-22 to -12 dBm	-30 dBm	LVPECL	E	-10°C to +80°C
<b>LTC1316 H</b>	1300 nm	2 km	Multi Mode	LED	-22 to -12 dBm	-30 dBm	LVPECL	H	-40°C to +85°C



Transmitter Logic							
Parameter	Function	Logic State	Logic Type	Min	Max	Units	Notes
Tx DIS	DISABLE	HIGH	LVTTL	2.4	3.3	V	Transmitter is OFF
Tx DIS	ENABLE	LOW	LVTTL	0	0.8	V	Transmitter is ON
Receiver Logic							
Parameter	Function	Logic State	Logic Type	Min	Max	Units	Notes
Rx_SD	LOSS OF SIGNALL	LOW	LVTTL	0	0.8	V	Receiver is OFF
	NORMAL	HIGH		2.4	3.3	V	Receiver is ON
	LOSS OF SIGNALL	LOW	LVPECL	Vcc-1.84	Vcc-1.60	V	Receiver is OFF
	NORMAL	HIGH		Vcc-1.10	Vcc-0.90	V	Receiver is ON

Transmitter Electro-Optical Characteristics						
Parameter	Symbol	LTC1316			Units	Notes
		Min	Typ	Max		
Signaling Rate		100			Mb/s	±100ppm, Fast Ethernet
		155			Mb/s	±100ppm, SONET OC-3/SDH STM-1
Transmitter Type		1300 nm LED				
Optical Output Power	P <sub>o</sub>	-22	-17	-12	dBm	Fiber type 62.5/125um
Extinction Ratio	E <sub>r</sub>	8	-	-	dB	
Center Wavelength	λ	1260	1300	1360	nm	
RMS Spectral Line Width	Δλ	-	-	80	nm	
Optical Rise and Fall Time	t <sub>r</sub> , t <sub>f</sub>	-	-	2.5	ns	20% - 80%
Jitter Peak-Peak	J <sub>pp</sub>	-	-	0.1	UI	
Output Eye		Compliant with ITU-T G.957				
Tx Differential Input Voltage	V <sub>IN</sub>	300	-	2400	mV p-p	LVPECL Tx DATA (Note 1)
Note 1: Internally AC-coupled and terminated						



Receiver Electro-Optical Characteristics						
Parameter	Symbol	LTC1316			Units	Notes
		Min	Typ	Max		
Receiver Type		PIN / TIA				
Receiver Optical Overload	P <sub>OL</sub>	-3	-	-	dBm	
Sensitivity	S	-	-	-30	dBm	Average Receiver Power (Note 1)
Center Wavelength	λ	1200	1300	1400	nm	
Signal Detect - Assert	P <sub>SDA</sub>	-45	-	-32	dBm	
Signal Detect - Deassert	P <sub>SDD</sub>	-45	-	-32	dBm	
Signal Detect - Hysteresis	P <sub>H</sub>	0.5	2	5	dB	
Rx Differential Load Impedance	Z <sub>LOAD</sub>	-	100	-	Ohms	
Rx Differential Output Voltage	V <sub>OUT</sub>	400	-	2000	mV p-p	LVPECL Rx DATA (Note 2)
Note 1: Average received power where the BER = 10 <sup>-10</sup> , measured with a 2 <sup>23</sup> -1 NRZ test pattern						
Note 2: Internally AC coupled						



### Transceiver Block Diagram

#### Transmitter Section

The transmitter section consists of a high reliability 1300 nm LED in an eye safe optical sub-assembly (TOSA), which is mated to the Tx port of the fiber optic LC duplex receptacle. A driver IC converts LVPECL differential input data signals into an analog current source that drives the LED. The transmitter is provided with the Tx\_Disable control function.

#### Receiver Section

The receiver section consists of a high-speed InGaAs PIN photodiode (PD) and transimpedance preamplifier mounted in an optical subassembly (ROSA), which is mated to the Rx port of the fiber optic LC duplex receptacle. The output of the PD drives the post-amplification, quantizing, and optical signal detection circuits. The receiver is equipped with the Rx\_SD (Signal Detect) monitoring function.

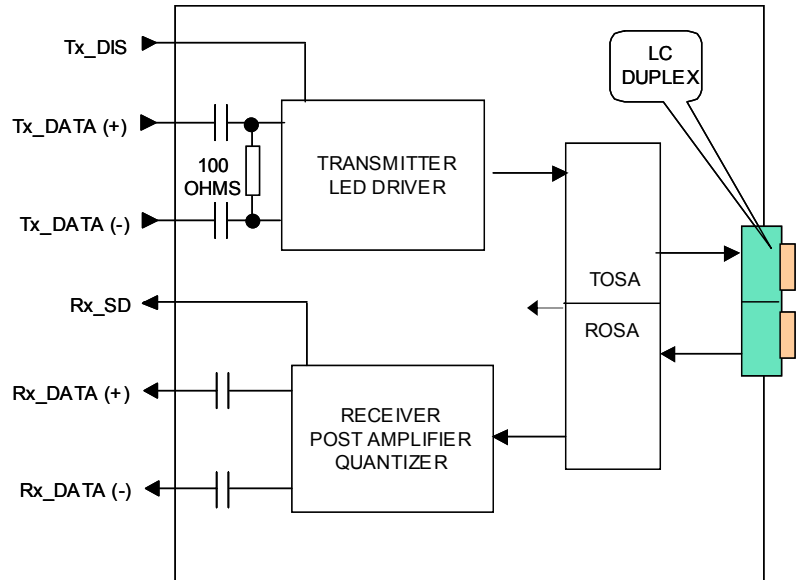

### Transceiver Monitor and Control Functions

#### Rx Signal Detect (SD) Description

The Rx\_SD (Signal Detect) is an open drain/collector LVTTTL or LVPECL monitor port. It switches state based on the received optical input signal level that passes through the photo detector (PD), post amplifier and quantizer. If the received signal is above the Rx threshold, then Rx\_SD is set HIGH indicating normal operation. If the received signal is below the Rx threshold, then Rx\_SD is set LOW indicating a possible broken fiber, unplugged connector or no Tx signal from the host.

#### Tx Disable (Tx\_DIS) Description

The Tx\_DIS (Transmit Disable) is an open drain/collector LVTTTL control port that is controlled by a logic signal on the host (system) printed circuit board. If the system is ready to send data then the Tx\_DIS line is set LOW to enable the transmitter. If the system is not ready to send data, then the Tx\_DIS line is set HIGH to disable the transmitter.



**SFF PIN ASSIGNMENT**

Pin	Symbol	Description
1	V <sub>EER</sub>	Receiver Signal Ground
2	V <sub>CCR</sub>	+3.3 Volt Receiver Power Supply
3	SD	LVTTL Signal Detect: LOW= No Signal, HIGH = Normal
4	RD-	Rx Data - Inverted Differential Output
5	RD+	Rx Data - Non Inverted Differential Output
6	V <sub>CCT</sub>	+3.3 Volt Transmitter Power Supply
7	V <sub>EET</sub>	Transmitter Signal Ground
8	Tx_DIS	LVTTL Transmit Disable: LOW = Normal, HIGH = Transmitter Disabled
9	TD+	Tx Data - Non Inverted Differential Input
10	TD-	Tx Data - Inverted Differential Input

Mounting Posts	The mounting posts are provided for mechanically attaching the transceiver to the circuit board. They should not be connected to the circuit ground but can be connected to the chassis ground.
Housing Leads	The housing leads should be connected to circuit ground
Notes	

1. The uncommitted SD and Tx\_DIS LVTTL monitor and control pins each require a pull up resistor of 4.7K to 10K Ohms.
2. The 100 Ohm differential Rx Data output is internally AC coupled and must be terminated with 100 Ohms at the differential user interface.
3. The 100 Ohm differential Tx Data input is internally AC coupled and terminated.

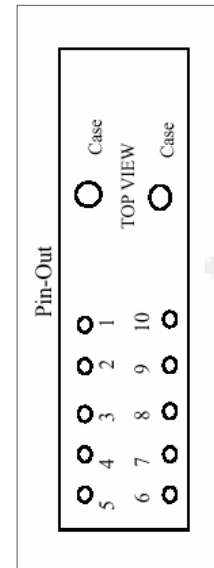

**Transceiver Pin Locations**

**Electrical Interface**

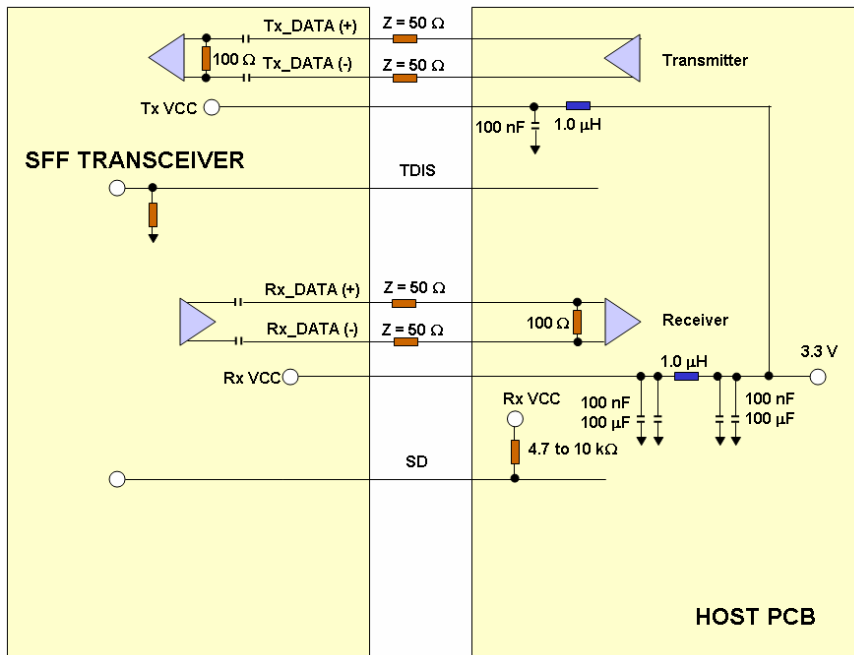





Regulatory Information

Eye Safety

The transceiver is a Class 1 eye-safe device according to FDA 21CFR1040.10 and IEC 60825-1.

Electromagnetic Interference (EMI), Immunity and Product Safety

The transceiver is ESD safe (electrical pins) when tested according to MIL-STD-883, Method 3015.7 and ESD safe (optical connector) when tested according to IEC 61000-4-2. The device is immune to strong RF fields when tested in accordance with IEC 610004-3. The device complies with (US) FCC, Part 15, Subpart J; (Europe) CENELEC EN 55022; (Canada) Class B (CISPR22A); and (Japan) VCCI Class 1. The device has been designed to conform to product safety requirements including UL1950, CSA 22.2, and IEC 60950-1, and has been designed to meets the flammability requirements of UL94.

Notice

The factory has made all adjustments to this device prior to shipment. No adjustments or modifications to the device are required or permitted. Any adjustment, modification or tampering of the device voids the product warranty. The US Food and Drug Administration may consider that any adjustment or modification to this device is an act of manufacturing and therefore will require that the device be recertified in accordance with 21 CFR 1040.10 Subpart j.

Laser Radiation Information	
Wavelength	1300 nm
FDA Total Pout: 7 mm aperture at 20 cm distance	< 195 microwatts
IEC Total Pout : 7 mm aperture at 10 cm distance	< 15,600 microwatts
Beam Divergence	17.25°

Required Label

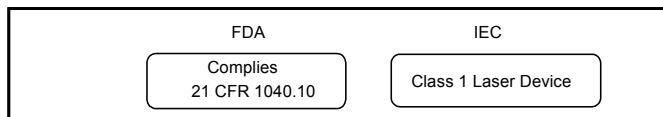

Laser Emission

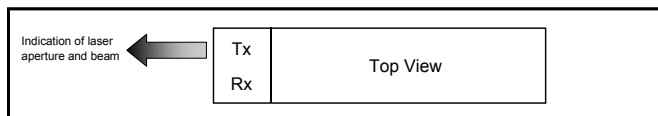



### Ligent Sales Offices

**Ligent Photonics**

2701 Dukane Drive  
Suite 200  
St. Charles, IL 60174  
PH (630) 513-7226  
FX (630) 513-9173  
WS [www.ligentphotonics.com](http://www.ligentphotonics.com)

**Ligent Photonics**

(Virginia Sales Office)  
8210 Strathmore Lane  
Roanoke, VA 24019  
PH (540) 797-5793  
FX (540) 366-5793  
WS [www.ligentphotonics.com](http://www.ligentphotonics.com)

**Bitel Technologies LTD**

Nur Building  
43 Ha'Atzmaut Way  
PO BOX 94  
Yehud, 56302, Israel  
PH +(972) 3-6322655  
FX +(972) 3-6322279  
WS [www.bitel.co.il](http://www.bitel.co.il)

**Gigatron Associates**

968 St. Laurent Boulevard  
Ottawa, Ontario K1K 3B3  
PH (613) 747-3472  
FX (613) 747-3474  
WS [www.gigatron.com](http://www.gigatron.com)

**Gigatron Associates**

56 Bartleman Crescent  
Cambridge, ON  
PH: (519) 220-1856  
FX: (510) 220-1938  
WS: [www.gigatron.com](http://www.gigatron.com)

**Gigatron Associates**

450 Avenue Racine PH #5  
Dorval, QB H9S 3K8  
PH: (514) 984-2598  
FX: (514) 620-7812  
WS: [www.gigatron.com](http://www.gigatron.com)

**Gigatron Associates**

2388 Eversyde Avenue SW  
Calgary, AB T2Y 4X6  
PH: (403) 257-0636  
FX: (403) 257-0569  
[www.gigatron.com](http://www.gigatron.com)

**Gigatron Associates**

406-838 Agnes Street  
New Westminster, BC V3M 6R3  
PH: (604) 787-2340  
FX: (604) 787-2343  
WS: [www.gigatron.com](http://www.gigatron.com)

**New Age Electronics**

3000 Northwood's Parkway  
Suite 280  
Norcross, GA 30071  
PH (770) 242-8800  
FX (770) 242-8180  
WS [www.newagelec.com](http://www.newagelec.com)

**New Age Electronics**

8376 Six Forks Road  
Suite 202  
Raleigh, NC 27615  
PH (919) 866-0620  
FX (919) 866-0621  
WS [www.newagelec.com](http://www.newagelec.com)

**New Age Electronics**

4900 Corporate Drive  
Suite B  
Huntsville, AL 35805  
PH (256) 430-8000  
FX (256) 430-8414  
WS [www.newagelec.com](http://www.newagelec.com)

**New Age Electronics**

182 Sunset Drive  
Mt. Dora, FL 32757  
PH: (352) 735-6101  
FX: (352) 735-6116  
WS: [www.newagelec.com](http://www.newagelec.com)

**New Age Electronics**

100 SE 5th Court  
Suite 37  
Pompano Beach, FL 33060  
PH: (407) 804-1210  
FX: (954) 928-2889  
WS: [www.newagelec.com](http://www.newagelec.com)

**KJS Marketing**

PO Box 72  
Crystal Lake, IL 60039  
PH (815) 788-1002  
FX (815) 788-1004  
WS [www.kjsmarketing.com](http://www.kjsmarketing.com)

**KJS Marketing**

7872 Olive Lane North  
Maple Grove, MN 55311  
PH (763) 391-6557  
FX (763) 391-6554  
WS [www.kjsmarketing.com](http://www.kjsmarketing.com)

**KJS Marketing**

2A Street  
Lake Lotawana, MO 64086  
PH (816) 578-4751  
FX (816) 774-2571  
WS [www.kjsmarketing.com](http://www.kjsmarketing.com)

**KJS Marketing**

1802 Hammer Drive, NW  
Cedar Rapids, IA 52405  
PH (319) 265-8592  
FX (319) 265-8593  
WS [www.kjsmarketing.com](http://www.kjsmarketing.com)

**KJS Marketing**

PO Box 1521  
Maryland Heights, MO 63043  
PH (314) 469-4544  
FX (314) 469-4535  
WS [www.kjsmarketing.com](http://www.kjsmarketing.com)

**KJS Marketing**

154 Struckman Blvd  
Bartlett, IL 60103  
PH (630) 289-4548  
FX (630) 289-3778  
WS [www.kjsmarketing.com](http://www.kjsmarketing.com)

**Kruvand Associates**

1202 Richardson Drive  
Suite 113  
Richardson, TX 75080  
PH (972) 437-3355  
FX (972) 680-8854  
WS [www.kruvand.com](http://www.kruvand.com)

**Kruvand Associates**

8100 Shoal Creek Boulevard  
Suite 250  
Austin, TX 75080  
PH (512) 454-1111  
FX (512) 454-9858  
WS [www.kruvand.com](http://www.kruvand.com)

**Kruvand Associates**

10601 Grant Road  
Suite 104  
Houston, TX 77070  
PH (713) 956-6741  
FX (713) 972-680-8854  
WS [www.kruvand.com](http://www.kruvand.com)

**K-Tech Sales**

100 Century Center Court  
Suite 405  
San Jose, CA 95112  
PH (408) 437-1808  
FX (408) 437-1883  
WS [www.ktechsales.com](http://www.ktechsales.com)