

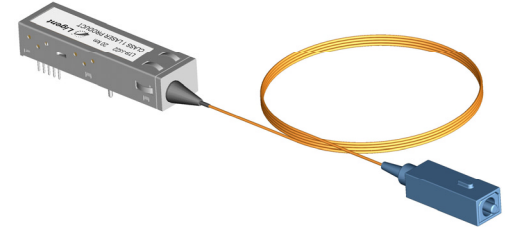

The LTB5332 bidirectional optical transceiver is ideally suited for 155 Mb/s to 622 Mb/s data rate FSAN (Full Service Access Network) point-to-point Fiber to the Home equipment as well as SONET/SDH OC-12, ATM and OLT PON applications. The built-in high isolation WDM enables full duplex operation up to 40 km over a single SMF fiber. The device is housed in a 2x5 small form factor (SFF) package with fiber pigtail. FC, MU and SC optical connectors are available options. The Tx section features a high performance 1550 nm MQW DFB laser assembly. The Rx section incorporates a high sensitivity 1310 nm PIN/TIA photo receiver with limiting amplifier. The Tx and Rx data ports incorporate the LVPECL interface. The device operates from a single 3.3-volt power supply. The Class I laser transmitter complies with international safety standards. This device is designed for operation over the extended temperature range of 0° to +75° Centigrade.



LTB5332

STANDARD SC/PC OPTICAL CONNECTOR

Applications

- Full Service Access Network (FSAN)
- Fiber to the Home (FTTH) OLT PON
- ATM, SONET, OC-12

- Differential LVPECL input and output interface
- Single ended LVTTTL Tx DISABLE function
- Single ended LVPECL Rx SD Alarm function
- Wave solderable and aqueous washable package
- Operating temperature range 0 to +75 °C

Features and Benefits

- Transmitter and receiver in a single compact package
- Tx/Rx distance up to 40 km
- Integral simplex SC connector
- Single fiber pigtail with SC/PC optical connector
- 100 mA nominal Tx section DC current
- 120 mA nominal Rx section DC current
- Industry standard SFF 2x5 outline
- 1550 nm MQW DFB laser diode transmitter
- High sensitivity 1310 nm PIN/TIA receiver with limiter
- Cross talk > -30 dB

Laser Safety

This device incorporates a Class 1 laser source and complies with IEC 825, U.S. FDA 21, CFR 1040.10 and 1040.11 (accession number 0210091-00) regulations. It must be operated within the specified temperature and voltage limits. The module optical ports module must be terminated with an optical connector or dust plug. Any internal modification to the transceiver renders the device non-compliant, voids any warranties and could result in a health hazard.

How to Order

Part Number	Data Rate	Transmitter	Receiver	Reach	Temperature Range	Package Option
LTB5332	622 Mb/s	1550 nm / DFB	1310 nm	40 km	0 to 75°C	SMF Pigtail with SC/PC Optical Connector
LTB5332 NC	622 Mb/s	1550 nm / DFB	1310 nm	40 km	0 to 75°C	SMF Pigtail without Optical Connector
LTB5332 FC	622 Mb/s	1550 nm / DFB	1310 nm	40 km	0 to 75°C	SMF Pigtail with FC/PC Optical Connector
LTB5332 MU	622 Mb/s	1550 nm / DFB	1310 nm	40 km	0 to 75°C	SMF Pigtail with MU/PC Optical Connector



Ligent

intelligent photonics

LTB5332 1550 nm Tx / 1310 nm Rx

40 km 155 / 622 Mb/s 2x5 SFF Pigtail Bi-Di Transceiver

Typical Operating Characteristics (T = 0 to +75 °C, VCC = 3.3 Volts)

Parameter	Symbol	MIN	TYP	MAX	Units
Power Supply	VCC	3.135	3.3	3.465	V
Bit Rate	BR	155	622	680	Mb/s
Transmitter Section (F-P Laser Transmitter)					
Optical Output (into 9/125 μ SMF)	P _{out}	-5	-	0	dBm
Tx Wavelength	λ _{out}	1480	1550	1580	nm
Side Mode Suppression Ratio	SMSR	30	-	-	dB
RMS Spectral Line Width @-20 dB	Δλ	-	-	1	nm
Extinction Ratio	ER	-	10	-	dB
Output Eye (Telcordia/Bellcore)	TR-NWT-000253 and ITU-T G.957 compliant				
Tx optical rise / fall time (10 - 90 %)	t _r	-	-	500	ps
Input Noise floor	R _{in}	-	-	-116	dB/√Hz
Total Jitter	T _j	-	-	1	nsec
Signal / Data Input Current (LOW)	I _{IL}	-350	-	-	μA
Signal / Data Input Current (HIGH)	I _{IH}	-	-	350	μA
Differential Signal Input Voltage	V _{IH-VIL}	300	-	-	mV p-p
Signal / Data Input Voltage (LOW)	V _{IL-VCC}	-2	-	-1.58	V
Signal / Data Input Voltage (HIGH)	V _{IH-VCC}	-1.1	-	-0.74	V
Receiver Section (PIN/TIA Receiver)					
Rx Optical Sensitivity (155 Mb/s or 622 Mb/s)	P _{in}	-	-	-26	dBm
Rx Operating Wavelength	λ _{in}	1260	1310	1360	nm
Rx Optical Pin Max	P _{in MAX}	-3	-	-	dBm
Signal Detect (ASSERT / Low to High)	P _a	-	-	-26	dBm
Signal Detect (DEASSERT / High to Low)	P _d	-36	-	-	dBm
Signal Detect Hysteresis	(P _a - P _d)	-	3.0	-	dB
Optical Return Loss	RL	14	-	-	dB
Signal Data Output Voltage - LOW	V _{IL-VCC}	-2	-	-1.58	Volts
Signal Data Output Voltage - HIGH	V _{IH-VCC}	-1.1	-	-0.74	Volts
Logic States: Tx ENABLE/DISABLE (LVTTTL); Rx SD (ECL 10K, 10KH, 100K, LVPECL)					
Tx ENABLE (Tx DIS = LOW)	Tx DISL	0	-	0.8	Volts
Tx DISABLE (Tx DIS = HIGH)	Tx DISH	VCC-1.3	-	VCC	Volts
Tx DISABLE shut off time	Tx DIS	-	-	1	msec
Rx SIGNAL DETECT (LOW)	V _{IL-VCC}	-2	-	-1.58	Volts
Rx SIGNAL DETECT (HIGH)	V _{IH-VCC}	-1.1	-	-0.74	Volts



Absolute Maximum Ratings				
Parameter	Symbol	Min	Max	Units
Storage Temperature	Tstg	-40	+85	°C
Operating Temperature	Tamb	0	+75	°C
Case Operating Temperature	Tcase	0	+80	°C
DC Supply	VCC	0	4.5	Volts
Signal / Data Input Voltage	Vin	GND	Vcc	Volts
Signal / Data Output Current	Iout	-	30	mA

BIDIRECTIONAL TRANSCEIVER BLOCK DIAGRAM

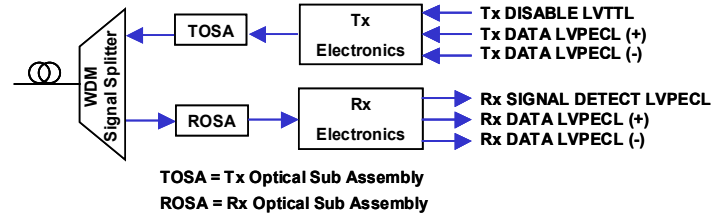

CIRCUIT DESIGN NOTES

- The circuit layout must minimize stray lead inductance that could generate unwanted (spurious) signals or unwanted RF oscillation.
- The input impedance for each phase of the differential input and output signals is 50 Ohms to ground (82 Ohms in parallel with 130 Ohms). The use of micro strip is recommended for each signal path.
- The parasitic inductance of leaded components may desensitize the receiver or reduce the transmitter drive signal (R+jwL). The use of high quality chip resistors and chip capacitors are recom-

mended.

- High-Q chokes are recommended for DC power supply decoupling to prevent a feedback path that can lead to unwanted RF oscillation. A 10 mF tantalum electrolytic capacitor is recommended for pulse charge storage.
- A ground plane on the bottom of the PCB may reduce the possibility of unwanted spurious signals and improve the sensitivity of the receiver. Plated through holes are recommended to minimize parasitic lead inductance.

SFF 2x5 Bi-Directional Transceiver Pin Description

Pin	Name	Level	Notes
1	Vee		Rx -DC, Ground
2	Vcc		Rx +DC Supply
3	Rx_SD	LVPECL	HIGH = Normal LOW = No Light
4	RDn	LVPECL	Rx Differential Data Out (-)
5	RDp	LVPECL	Rx Differential Data Out (+)
6	Vcc		Tx +DC Supply
7	Vee		Tx -DC, Ground
8	Tx_DIS	LVTTL	LOW = Normal HIGH = Tx Disable
9	TDp	LVPECL	Tx Differential Data In (+)
10	TDn	LVPECL	Tx Differential Data In (-)

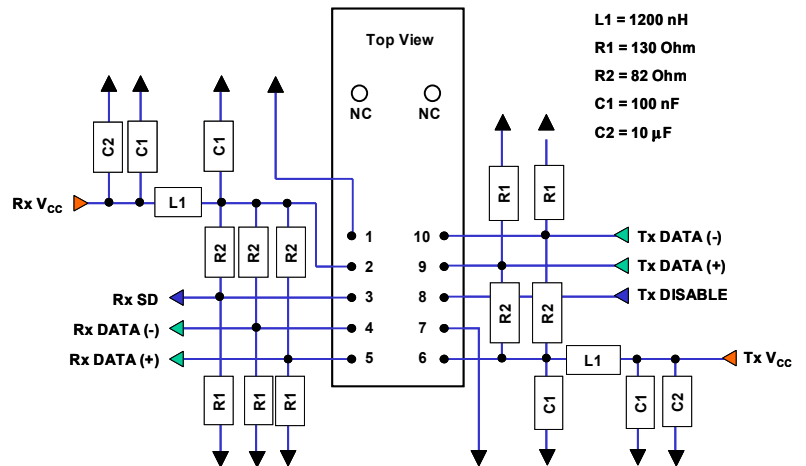



2X5 SFF PIGTAIL OUTLINE DRAWING

Dimensions are in mm

Tolerances are ±0.01 mm

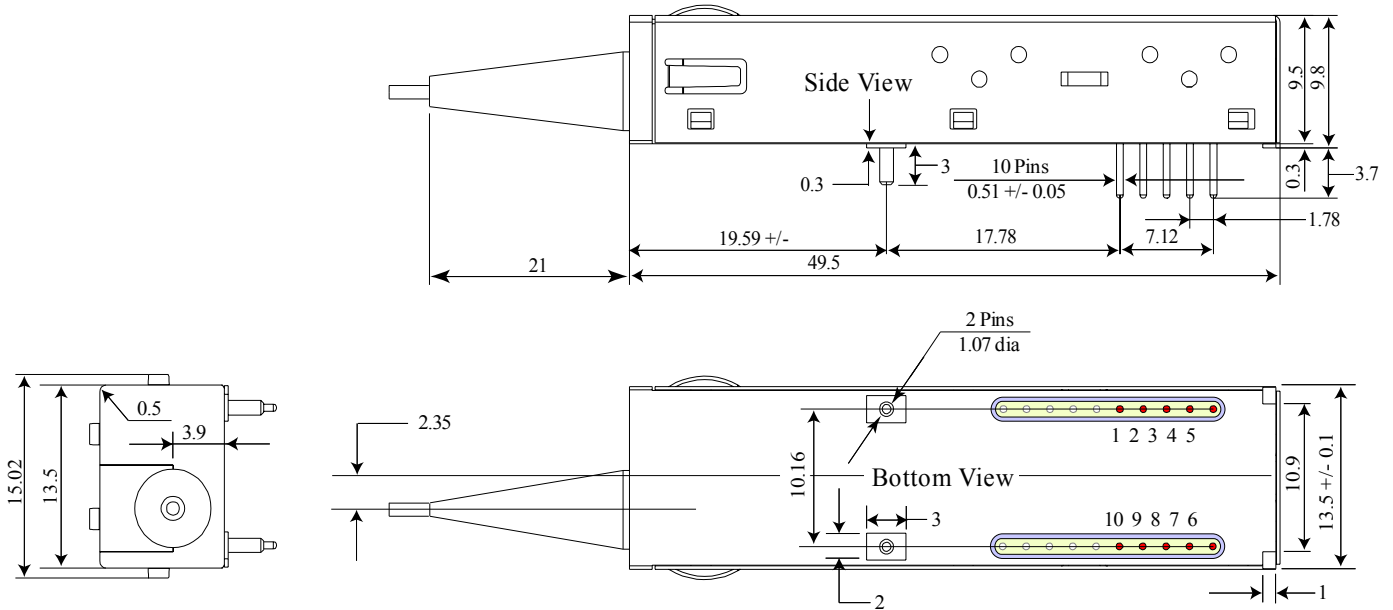

LTB5332 Change History

Change No	Page No	Date	Rev No	Approved	Description
0001	All	23 Jan 06	2.0	JS	Title changed to include 155 Mb/s data rate, 2x5 SFF package
0001	All	23 Jan 06	2.0	JS	Page count changed from 2 to 4 pages, footer shows Rev 2.0, 23 Jan 2006
0001	1	23 Jan 06	2.0	JS	New page layout - moved HOW TO ORDER table to Page 1
0001	1	23 Jan 06	2.0	JS	Product photo replaces mechanical drawing of SFF pigtail product
0001	2	23 Jan 06	2.0	JS	New page layout - moved table of OPERATING CHARACTERISTICS to Page 2
0001	2	23 Jan 06	2.0	JS	Added 155 Mb/s to Bit Rate (OPERATING CHARACTERISTICS)
0001	2	23 Jan 06	2.0	JS	Added symbol "BR" to Bit Rate (OPERATING CHARACTERISTICS)
0001	2	23 Jan 06	2.0	JS	Added "155 Mb/s or 622 Mb/s" to Rx Sensitivity (OPERATING CHARACTERISTICS)
0001	2	23 Jan 06	2.0	JS	Added "(Pa - Pd)" as hysteresis symbol (OPERATING CHARACTERISTICS)
0001	3	23 Jan 06	2.0	JS	New Page 3 added
0001	3	23 Jan 06	2.0	JS	Added new Block Diagram and Pin Out drawings
0001	4	23 Jan 06	2.0	JS	New Page 4 added
0001	4	23 Jan 06	2.0	JS	Added new 2x5 SFF drawing (boot length = 21 mm)
0001	4	23 Jan 06	2.0	JS	Added table "LTB5332 Change History"