

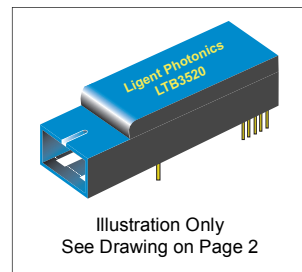

The LTB3521 bidirectional optical transceiver is ideally suited for 622 Mb/sec data rate FSAN (Full Service Access Network) point-to-point Fiber to the Home equipment as well as SONET/SDH OC-12, ATM and ONU PON applications. The built-in high isolation WDM enables full duplex operation up to 20 km over a single SMF fiber. The device is housed in a 2x5 small form factor (SFF) package with the SC optical receptacle. The Tx section features a high performance 1310 nm MQW F-P laser assembly. The Rx section incorporates a high sensitivity 1550 nm PIN/TIA photo receiver with limiting amplifier. The Tx and Rx data ports incorporate the LVPECL interface. The device operates from a single 3.3-volt power supply. The Class I laser transmitter complies with international safety standards. This device is designed for operation over the extended temperature range of -40° to +85° Centigrade.



**Applications**

- Full Service Access Network (FSAN)
- Fiber to the Home (FTTH) ONU PON
- ATM, SONET, OC-12

**Features and Benefits**

- Transmitter and receiver in a single compact package
- Tx/Rx distance up to 20 km
- Single fiber pigtail with SC/PC optical connector
- Single +3.3V power supply
- 100 mA nominal Tx section DC current
- 120 mA nominal Rx section DC current
- Industry standard SFF 2x5 outline
- 1310 nm MQW F-P laser diode transmitter
- High sensitivity 1550 nm PIN/TIA receiver with limiter
- Cross talk > -30 dB
- Differential LVPECL input and output interface
- Single ended LVTTTL Tx DISABLE function
- Single ended LVPECL Rx SD Alarm function
- Wave solderable and aqueous washable package
- Operating temperature range -40 to +85 °C

**Laser Safety**

This device incorporates a Class 1 laser source and complies with IEC 825, U.S. FDA 21, CFR 1040.10 and 1040.11 (accession number 0210091-00) regulations. It must be operated within the specified temperature and voltage limits. The module optical ports module must be terminated with an optical connector or dust plug. Any internal modification to the transceiver renders the device non-compliant, voids any warranties and could result in a health hazard.

**Absolute Maximum Ratings**

Parameter	Symbol	Min	Max	Units
Storage Temperature	Tstg	-40	+85	°C
Operating Temperature	Tamb	-40	+85	°C
DC Supply	VCC	0	4.5	Volts
Signal / Data Input Voltage	Vin	GND	Vcc	Volts
Signal / Data Output Current	Iout	-	30	mA

**Typical Operating Characteristics (T = -40 to +85 °C, VCC = 3.3 Volts)**

Parameter	Symbol	MIN	TYP	MAX	Units
Power Supply	VCC	3.135	3.3	3.465	V
Bit Rate	-	-	622	680	Mb/sec
<b>Transmitter Section (F-P Laser Transmitter)</b>					
Optical Output (into 9/125 μ SMF)	Pout	-14	-	-8	dBm
Tx Wavelength	λout	1260	1310	1360	nm
RMS Spectral Line Width	Δλ	-	-	4	nm
Extinction Ratio	ER	-	10	-	dB
Output Eye (Telcordia/Bellcore)	TR-NWT-000253 and ITU-T G.957 compliant				
Tx optical rise / fall time (10 - 90 %)	tr	-	-	500	ps
Input Noise floor	Rin	-	-	-116	dB/√Hz
Total Jitter	Tj	-	-	1	nsec
Signal / Data Input Current (LOW)	IIL	-350	-	-	μA
Signal / Data Input Current (HIGH)	IIH	-	-	350	μA
Differential Signal Input Voltage	VIH-VIL	300	-	-	mV p-p
Signal / Data Input Voltage (LOW)	VIL-VCC	-2	-	-1.58	V
Signal / Data Input Voltage (HIGH)	VIH-VCC	-1.1	-	-0.74	V
<b>Receiver Section (PIN/TIA Receiver)</b>					
Rx Optical Sensitivity	Pin	-	-	-26	dBm
Rx Operating Wavelength	λin	1480	1550	1580	nm
Rx Optical Pin Max	Pin MAX	-3	-	-	dBm
Signal Detect (ASSERT / Low to High)	Pa	-	-	-26	dBm
Signal Detect (DEASSERT / High to Low)	Pd	-36	-	-	dBm
Signal Detect Hysteresis	None	-	3.0	-	dB
Optical Return Loss	RL	14	-	-	dB
Signal Data Output Voltage - LOW	VIL-VCC	-2	-	-1.58	Volts
Signal Data Output Voltage - HIGH	VIH-VCC	-1.1	-	-0.74	Volts
<b>Logic States: Tx ENABLE/DISABLE (LVTTTL); Rx SD (ECL 10K, 10KH, 100K, LVPECL)</b>					
Tx ENABLE (Tx DIS = LOW)	Tx DISL	0	-	0.8	Volts
Tx DISABLE (Tx DIS = HIGH)	Tx DISH	VCC-1.3	-	VCC	Volts
Tx DISABLE shut off time	Tx DIS	-	-	1	msec
Rx SIGNAL DETECT (LOW)	VIL-VCC	-2	-	-1.58	Volts
Rx SIGNAL DETECT (HIGH)	VIH-VCC	-1.1	-	-0.74	Volts

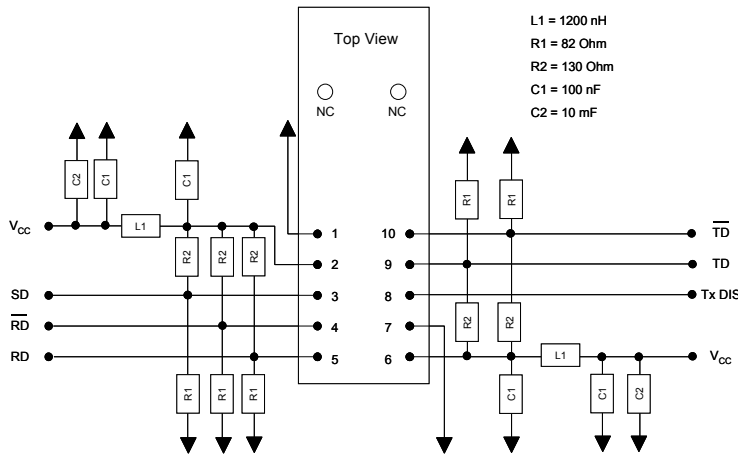

**SFF 2X5 Bi-Directional Transceiver Pin Description**

Pin	Name	Level	Notes
1	Vcc		Rx -DC, Ground
2	Vcc		Rx +DC Supply
3	Rx_SD	LVPECL	HIGH = Normal; LOW = No Light
4	RDn	LVPECL	Rx Differential Data Out (-)
5	RDp	LVPECL	Rx Differential Data Out (+)
6	Vcc		Tx +DC Supply
7	Vee		Tx -DC, Ground
8	Tx_DIS	LVTTTL	LOW = Normal, HIGH = Tx Disable
9	TDp	LVPECL	x Differential Data In (+)
10	TDn	LVPECL	Tx Differential Data In (-)

**Circuit Design Notes**

- The circuit layout must minimize stray lead inductance that could generate unwanted (spurious) signals or unwanted RF oscillation.
- The input impedance for each phase of the differential input and output signals is 50 Ohms to ground (82 Ohms in parallel with 130 Ohms). The use of micro strip is recommended for each signal path.
- The parasitic inductance of leaded components may desensitize the receiver or reduce the transmitter drive signal ( $R+j\omega L$ ). The use of high quality chip resistors and chip capacitors are recommended.
- High-Q chokes are recommended for DC power supply decoupling to prevent a feedback path that can lead to unwanted RF oscillation. A 10 mF tantalum electrolytic capacitor is recommended for pulse charge storage.
- A ground plane on the bottom of the PCB may reduce the possibility of unwanted spurious signals and improve the sensitivity of the receiver. Plated through holes are recommended to minimize parasitic lead inductance.

**Bi-Directional Transceiver Block Diagram**

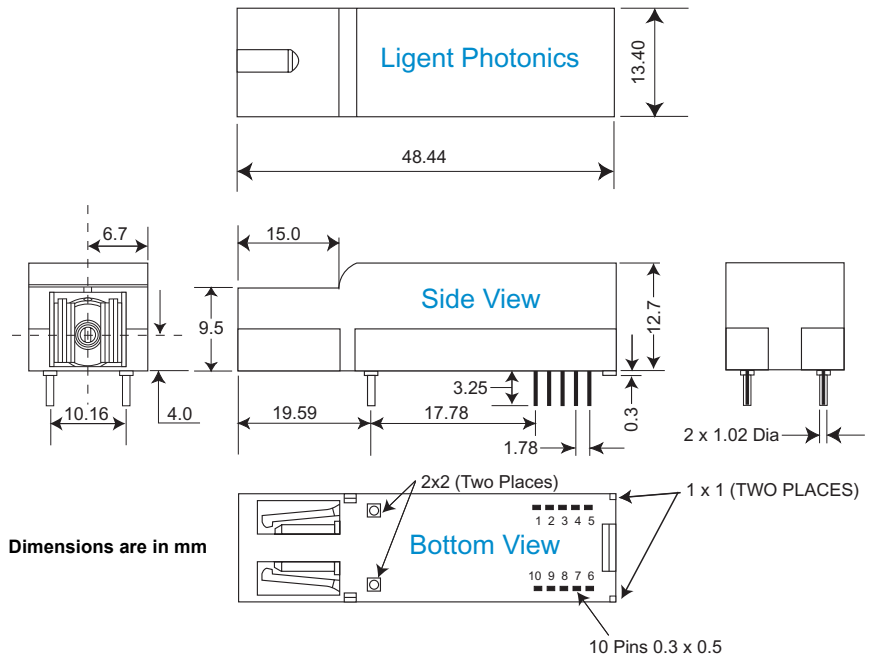
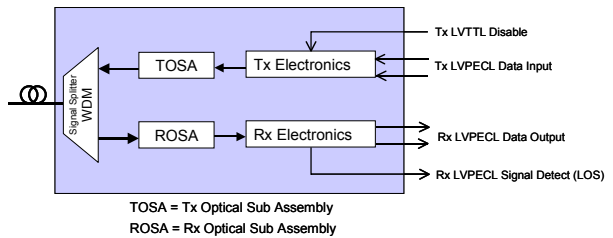

**How to Order**

Part Number	Data Rate	Transmitter	Receiver	Reach	Temperature Range	Package Option
LTB3521 SC	622 Mb/sec	1310 nm / F-P	1550 nm	20 km	-40 to 85 °C	SC Optical Receptacle