

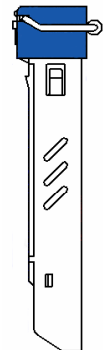

The LTB3509 bidirectional optical transceiver is ideally suited for 1250 Mb/sec Fiber to the Home, Business or Curb and Gigabit Ethernet Access Networks ONU PON applications where a single SMF fiber is required to simultaneously carry both Tx and Rx signals up to 10 km. The built-in high isolation WDM enables full duplex operation. It is mounted in the MSA compliant 2x10 small form pluggable (SFP) package with the SC optical receptacle. The transmitter and receiver subassemblies incorporate a high performance 1310 nm MQW F-P laser assembly and high sensitivity 1490 nm PIN/TIA photo receiver with limiting amplifier. The differential internally AC coupled Tx and Rx data interfaces are LVPECL compatible. The Rx_LOS, Tx_DIS and Tx_FAULT monitor and control functions are LVTTTL compatible. The two-wire I²C interface is compatible with the SFF MSA digital diagnostic standard. It operates from a single 3.3-volt power supply and is rated for operation over the temperature range of -20°C to +75°C. The Class I laser transmitter complies with international safety standards.



Applications

- Fiber to the Home (FTTH) ONU PON
- Gigabit Ethernet Access Networks

Features and Benefits

- Transmitter and receiver in a single compact package
- Tx/Rx distance up to 10 km
- Integral simplex SC connector
- Single +3.3V power supply
- 60 mA nominal Tx section DC current
- 100 mA nominal Rx section DC current
- Industry standard SFP 2x10 outline
- 1310 nm F-P laser diode transmitter
- High sensitivity 1490 nm PIN/TIA receiver with limiter
- Cross talk > -40 dB
- Differential AC-coupled LVPECL input and output interface
- Operating temperature range -20°C to +75°C

Monitor and Control Functions

- Rx_LOS LVTTTL
- Tx_DIS LVTTTL
- Tx_FAULT LVTTTL
- SDA LVTTTL / LVCMOS
- SCL LVTTTL / LVCMOS

Laser Safety

This device incorporates a Class 1 laser source and complies with IEC 825, U.S. FDA 21, CFR 1040.10 and 1040.11 regulations. It must be operated within the specified temperature and voltage limits. The module optical ports must be terminated with an optical connector or dust plug. Any internal modification to the transceiver renders the device non-compliant, voids any warranties and could result in a health hazard.

Recommended Operating Conditions					
Parameter	Symbol	Min	Typ	Max	Units
Ambient Operating Temperature	T _{amb}	-20	25	75	°C
DC Supply Voltage	V _{CC}	3.135	3.3	3.465	Volts
Module Supply Current	I _{IN}	-	160	210	mA
Module Power Dissipation	P _D	-	525	700	mW
Signaling Speed +/- 100 ppm	S	-	1250	-	Mb/s
Useful Reach	D	-	10	-	km
Ordering Information					
Part Number	Description				
LTB3509	SFP Bidirectional Transceiver, 1310 nm Tx, 1490 Rx				



Absolute Maximum Ratings

Parameter	Symbol	Min	Max	Units	
Storage Temperature	Tstg	-40	+85	°C	Exceeding the Absolute Maximum Ratings may cause irreversible damage to the device.
Operating Temperature Range	Tamb	-20	+75	°C	
DC Supply	VCC	0	3.6	Volts	
Relative Humidity - Storage	RH _s	0	95	%	The device is not intended to be operated under the condition of simultaneous Absolute Maximum Ratings, a condition which may cause irreversible damage to the device.
Relative Humidity - Operating	RH _o	0	85	%	

Control and Monitor Function Logic Levels

Parameter	State	Min	Max	Units	Condition	Notes
Rx_LOS	HIGH	2.0	V _{cc} + 0.3	V	Receiver OFF	Requires 4.7 K to 10 K Pull-Up
	LOW	0	0.8	V	Receiver ON	
Tx_DIS	HIGH	2.0	V _{cc} + 0.3	V	Laser OFF	Incorporates internal 4.7 K to 10 K Pull-Up
	LOW	0	0.8	V	Laser ON	
Tx_FAULT	HIGH	2.0	V _{cc} + 0.3	V	Laser FAULT	Requires 4.7 K to 10 K Pull-Up
	LOW	0	0.8	V	Laser NORMAL	
SDA	HIGH	2.0	V _{cc} + 0.3	V	I2C Serial Data	Requires 4.7 K to 10 K Pull-Up
	LOW	0	0.8	V		
SCL	HIGH	2.0	V _{cc} + 0.3	V	I2C Serial CLOCK	Requires 4.7 K to 10 K Pull-Up
	LOW	0	0.8	V		

Transmitter Electrical and Optical Characteristics (Tamb = -20 to +75°C, Vcc = 3.3 V unless otherwise noted)

Parameter	Symbol	Min	Typ	Max	Units	Conditions / Notes
Transmitter Type		1310 nm F-P				
Transmitter Monitor and Control		Tx_FAULT, Tx_DISABLE				
Average Output Power (9/125 μ SMF)	P _{out}	-9	-	-3	dBm	
Extinction Ratio	ER	6	9	-	dB	
Optical Rise and Fall Time	t _r / t _f	-	150	260	ps	20% to 80%
Tx Wavelength	λ	1270	1310	1350	nm	
Spectral Line Width	Δλ	-	-	3.5	nm	
Relative Intensity Noise	RIN	-	-	-113	dB/Hz	
Optical Cross Talk	CT	-	40	-	dB	
Transmit Reflectance	RFL	-	-	-12	dB	
DC Supply Current	I _{CC}	-	60	90	mA	
Differential Input Voltage		350	-	1600	mV	Peak to Peak
Tx_DATA Input Load Impedance	R _{IN}	2500	-	-	Ohms	



Receiver Optical Specifications (Tamb = -20 to +75°C, Vcc = 3.3 V unless otherwise noted)

Parameter	Symbol	Min	Typ	Max	Units	Conditions / Notes
Receiver Type		1490 nm PIN/TIA				
Optical Signal Indicator		Signal Detect				
Wavelength	λ	1100	1490	1670	nm	
Received Optical Power	P _{in}	-20	-	-3	dBm	BER<10 ⁻¹⁰ , 1250 Mb/s, PRBS 2 ²³ -1
Receiver Reflectance	RFL	-	-	-12	dB	
Receiver Settling Time	t _{rx}	-	150	260	ps	20% to 80%
Rx_LOS Range	P _a	-33	-	-19	dBm	
Rx_LOS Hysteresis	P _{hy}	-	3	5	dB	
Rx_LOS Output Load	R _{SDL}	-	50	-	Ohms	To Vcc-2
Cross Talk	CT	-	-	-40	dB	
DC Supply Current	I _{CCR}	-	100	120	mA	Not including RX_DATA load current
Data Output Voltage	V _{out}	-	800	-	mV	Single ended output
Rx_DATA Load Impedance	R _{DL}	-	50	-	Ohms	To Vcc-2



PIN ASSIGNMENT

20		VEET
19		TD-
18		TD+
17		VEET
16		VCCT
15		VCCR
14		VEER
13		RD+
12		RD-
11		VEER

1		VEET
2		Tx_FAULT
3		Tx_DIS
4		MOD_DEF 2
5		MOD_DEF 1
6		MOD_DEF 0
7		Rate Select
8		Rx_LOS
9		VEER
10		VEER

Transceiver Electrical Pad Layout
Top View
Bottom View

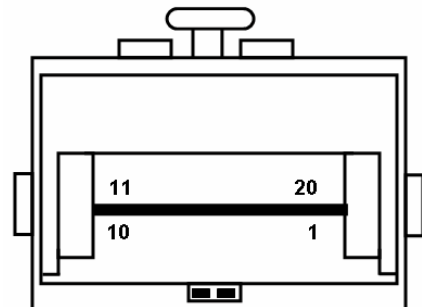

Transceiver Pin Locations

SFP Pin Assignment

Pin	Symbol	Logic Type	Description	Notes
1	V _{EET}	N/A	Transmitter Ground	
2	TX_FAULT	LVTTTL	Transmitter Fault, LOW = Normal Operation, HIGH = Fault Indication	Note 1
3	TX_DIS	LVTTTL	Transmit Disable, LOW = Normal Operation, HIGH = Disables Module	Note 1
4	MOD_DEF 2	LVTTTL	Module Definition 2 - Two-Wire Interface - Serial Data	Note 1
5	MOD_DEF 1	LVTTTL	Module Definition 1 - Two-Wire Interface - Clock Signal	Note 1
6	MOD_DEF 0	LVTTTL	Module Definition 0 - Two-Wire Interface Digital Ground	
7	Rate Select	N/A	Not Connected	
8	RX_LOS	LVTTTL	Receiver Loss of Signal, LOW = Normal Operation, HIGH = Loss of Signal	Note 1
9	V _{EER}	N/A	Receiver Ground	
10	V _{EER}	N/A	Receiver Ground	
11	V _{EER}	N/A	Receiver Ground	
12	RD-	LVPECL	RX_Data Output (Inverted)	Note 2
13	RD+	LCPECL	RX_Data Output (Non Inverted)	Note 2
14	V _{EER}	N/A	Receiver Ground	
15	V _{CCR}	N/A	Receiver DC Power	3.3 V +/- 5%
16	V _{CCT}	N/A	Transmitter DC Power	3.3 V +/- 5%
17	V _{EET}	N/A	Transmitter Ground	
18	TD+	LVPECL	TX_Data Input (Non Inverted)	Note 3
19	TD-	LVPECL	TX_Data Input (Inverted)	Note 3
20	V _{EET}	N/A	Transmitter Ground	

Notes

- The uncommitted TX_Fault, RX_LOS, MOD_DEF 1 and MOD_DEF 2 LVTTTL monitor and control pins each require a pull up resistor of 4.7K to 10K Ohms
- The 100 Ohm differential RX Data output is internally AC coupled and must be terminated with 100 Ohms at the differential user interface.
- The 100 Ohm differential TX Data input is internally AC coupled and terminated.



TRANSCEIVER BLOCK DIAGRAM

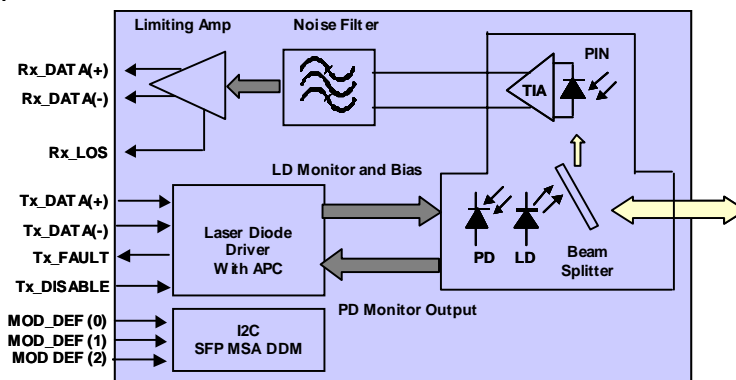

APPLICATIONS INFORMATION

Transmitter Section

The transmitter section consists of a high reliability 1310 nm F-P laser diode (LD) with back facet monitor photo detector (PD). A driver IC converts the LVPECL differential input data signal into an analog current source that drives the LD. The APC circuit provides for temperature compensation of the laser diode thereby stabilizing the output power and the extinction ratio. The transmitter is provided with the TX_DISABLE and TX_FAULT control and monitoring functions. The SFP MSA digital diagnostics are enabled via the 2-wire I²C data bus.

TX_FAULT

The TX_FAULT monitor function is implemented as an open collector/drain output. It requires a 4,700 to 10,000 Ohm Pull Up resistor on the host PCB. Logic HIGH (2.0 to 3.465V) indicates a laser fault, which can be caused by excessive optical output power or excessive laser drive current. Logic LOW (0 to 0.8V) indicates normal operation. The TX_FAULT can be reset by toggling the TX_DISABLE line. When the logic voltage is >0.8V and <2.0V, the logic state is undefined.

TX_DISABLE

The TX_DISABLE is a control function that can be used to shut down the transmitter optical output. It incorporates an internal 4,700 to 10,000 Ohm Pull Up resistor. Logic HIGH (2.0 to 3.465V) shuts down the transmitter. Logic LOW (0 to 0.8V) enables the transmitter. When the logic voltage is >0.8V and <2.0V, the logic state is undefined. If the TX_DISABLE port is open the transmitter is disabled.

TX_DATA

Tx_DATA (Inverted) and Tx_DATA (Non Inverted) are the differential transmitter input signal lines. They are internally AC-coupled and differentially terminated with 100 Ohms. The inputs will accept differ-

ential swings of 500 – 2400 mV (250 – 1200 mV single-ended), though it is recommended that values between 500 and 1200 mV differential (250 – 600 mV single-ended) be used for best EMI performance.

Receiver Section

The receiver optical subassembly (ROSA) incorporates a planar In-GaAs PIN photo detector, which can detect optical signals in the range of 1100 nm to 1700 nm. The high-reliability photo detector is characterized by its low dark current. The receiver electronics includes an integrated low noise preamplifier and AGC amplifier (TIA), which are mounted in a TO-Metal Can assembly with the photo detector. The TIA drives the band pass filter (BPF) and limiting amplifier. The differential output of the limiting amplifier is LVPECL compatible. The receiver is provided with the Rx_SIGNAL DECECT monitor function.

Rx_LOS

The Rx_LOS monitor function is an open collector/drain output. It requires a 4,700 to 10,000 Ohm Pull Up resistor on the host PCB. Logic HIGH (2.0 to 3.465V) indicates loss of signal, which can be caused by “no signal” arriving at the optical input, a weak signal arriving at the optical input, a broken fiber or a disconnected optical connector. Logic LOW (0 to 0.8V) indicates normal operation. When the logic voltage is >0.8V and <2.0V, the logic state is undefined.

Rx_DATA

The Rx_DATA (Inverted) and Rx_DATA (Non Inverted) are differential receiver output signal lines. They are internally AC-coupled and require a 100 OHM differential termination at the user interface. The voltage swing on these lines will be between 370 and 2000 mV differential (185 – 1000 mV single ended) when properly terminated.



RECOMMENDED INTERFACE CIRCUIT

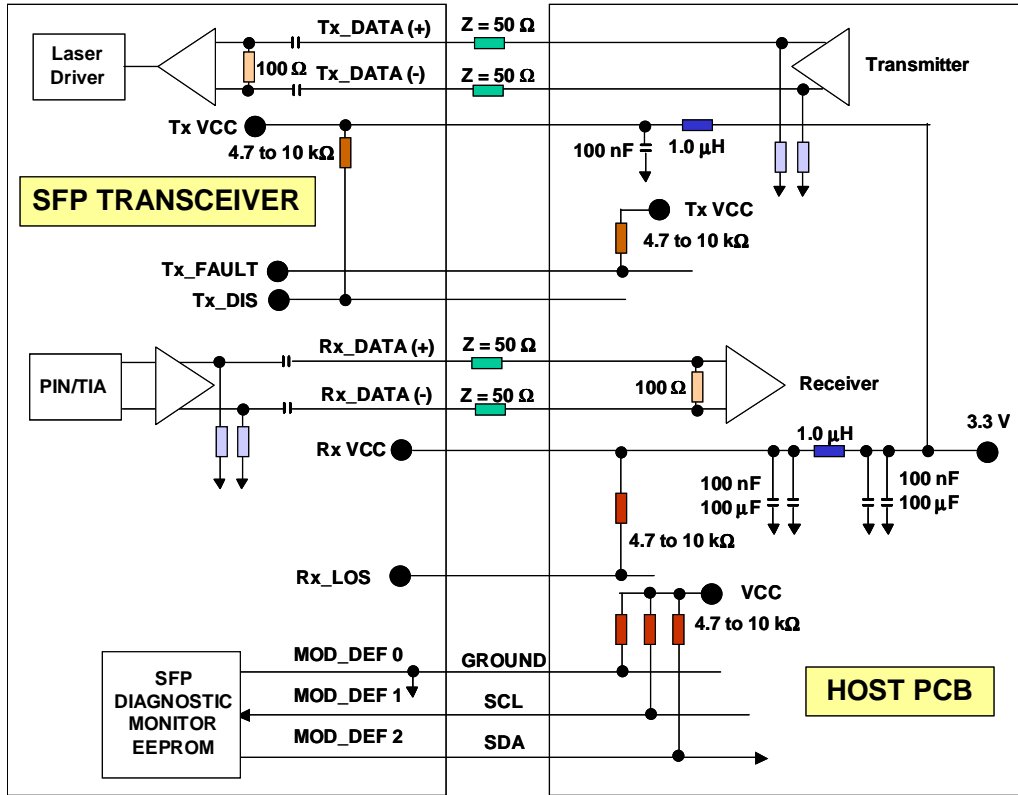

SFP OUTLINE

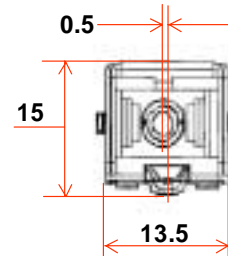
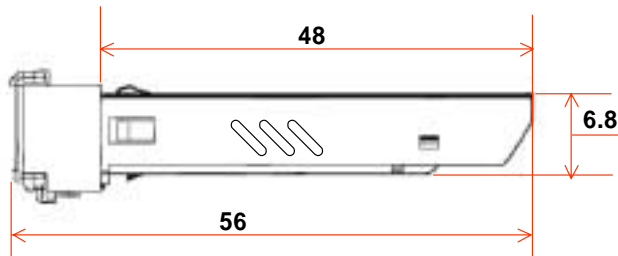

Dimensions are in mm



REGULATORY INFORMATION

Eye Safety

The transceiver is a Class 1 eye-safe device according to FDA 21CFR1040.10 and IEC 60825-1.

Electromagnetic Interference (EMI), Immunity and Product Safety

The transceiver is ESD safe (electrical pins) when tested according to MIL-STD-883, Method 3015.7 and ESD safe (optical connector) when tested according to IEC 61000-4-2. The device is immune to strong RF fields when tested in accordance with IEC 610004-3. The device complies with (US) FCC, Part 15, Subpart J; (Europe) CENELEC EN 55022; (Canada) Class B (CISPR22A); and (Japan) VCCI Class 1. The device has been designed to conform to product safety requirements including UL1950, CSA 22.2, and IEC 60950-1, and has been designed to meet the flammability requirements of UL94.

Notice

The factory has made all adjustments to this device prior to shipment. No adjustments or modifications to the device are required or permitted. Any adjustment, modification or tampering of the device voids the product warranty. The US Food and Drug Administration may consider that any adjustment or modification to this device is an act of manufacturing and therefore will require that the device be recertified in accordance with 21 CFR 1040.10 Subpart j.

Laser Radiation Information	
Wavelength	1300 nm
FDA Total Pout: 7 mm aperture at 20 cm distance	< 195 microwatts
IEC Total Pout : 7 mm aperture at 10 cm distance	< 15,600 microwatts
Beam Divergence	17.25°

Required Label

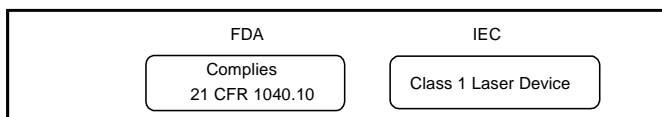

Laser Emission

