



LTB3443 622 Mbps Tx / 155 Mbps Rx P2MP OLT 2x10 SFF B-PON Class B Transceiver

The LTB3443 is a low cost point to multi point (P2MP) Fiber to the Home, Business or Curb (FTTx) B-PON OLT transceiver. It is designed for 622.08 Mb/s downstream / 155.52 Mb/s upstream duplex data links that employ high-speed burst mode TDM receivers/transmitters. It is based on the ITU-T G.983.1 and G.983.3 specification for bidirectional communications over a single fiber and incorporates a high performance 1310 nm Burst Mode APD/TIA receiver and 1490 nm CW mode DFB transmitter. It is intended to serve up to 16 subscribers over distances of up to 10 km. The Receiver Signal Detect (Rx_SD), Transmit Disable (Tx_DIS), Transmit Fault (Tx_FAULT) and the Page A0 (HEX) I²C diagnostic interface (equivalent to SFP MSA specification) monitor and control functions are LVTTTL compatible. The high-speed Receiver Reset (Rx_RESET) control function is LVTTTL compatible. The industry standard 2x10 small form factor (SFF) package incorporates a pigtail fiber with SC/APC or SC/UPC optical connector. It is fabricated with a rugged die cast metal housing and cage assembly and operates over the temperature range from 0°C to +75°C.



Applications

- Access Networks
- Fiber to the Home, Curb, Office (FTTx)
- Point to Multi Point Service (P2MP)
 - Up to 10 km Reach (16:1 Split)
 - Class B FSAN B-PON OLT

Features

- Dual Wavelength Bidirectional Transceiver
- 622.08 Mb/s Downstream
- 155.52 Mb/s Upstream
- BER<10⁻¹⁰, 155.52 Mb/s, PRBS 2²³-1
- 1310 nm APD/TIA Burst Mode Receiver
- 1490 nm CW Mode DFB Laser
- ITU-G.983.1 and G.983.3 Complaint
- Single 3.3 Volt DC supply
- Low Power Consumption
- 2x10 SFF Package Outline
- Single Fiber, Full Duplex Operation
- Fiber Pigtail with Optional Optical Connector
- 0°C to 75°C Operating Temperature Range

Electrical Interface

- Tx DATA
 - LVPECL Differential Data Interface
 - Internally AC Coupled and Terminated
- Rx DATA
 - LVPECL Differential Data Interface
 - Internally DC Coupled
- LVTTTL Monitor and Control Interfaces
 - Rx Signal Detect
 - Rx RESET
 - Tx Disable
 - Tx Fault
 - I²C Serial Data (Page A0 HEX)
 - I²C Serial Clock

Recommended Operating Conditions					
Parameter	Symbol	Min	Typ	Max	Units
Ambient Operating Temperature	T _{amb}	0	25	75	°C
DC Supply Voltage	V _{CC}	3.135	3.3	3.465	Volts
Module Supply Current	I _{IN}	-	150	200	mA
Module Power Dissipation	P _D	-	500	700	mW
Downstream Signaling Speed +/- 100 ppm	Sdown	-	622.08	-	Mb/s
Upstream Signaling Speed +/- 100 ppm	Sup	-	155.52	-	Mb/s
Useful Reach (16:1 Split)	D	-	10	-	km

Ordering Information	
Part Number	Package Option (X)
LTB3443 X	A Pigtail, no connector
	B Pigtail, SC/APC
	C Pigtail, SC/PC



Absolute Maximum Ratings					
Parameter	Symbol	Min	Max	Units	Notes
Storage Temperature	T _{stg}	-40	+85	°C	Exceeding the Absolute Maximum Ratings may cause irreversible damage to the device.
Operating Temperature	T _O	0	+75	°C	
Relative Humidity - Storage	RH _S	0	95	%	
Relative Humidity - Operating	RH _O	0	85	%	The device is not intended to be operated under the condition of simultaneous Absolute Maximum Ratings, a condition which may cause irreversible damage to the device.
DC Supply Voltage	V _{CC}	0	3.6	V	
Soldering Temperature	T _{slid}	0	260	°C	
Soldering Duration	t _{slid}	0	10	sec	

Absolute Maximum Ratings: Control Function Logic Levels					
Parameter	Symbol	Min	Max	Units	Notes
Transmit DISABLE Logic HIGH State	Tx_DIS	0	V _{CC} +0.5	V	LVTTTL
Transmit FAULT Logic HIGH State	Tx_FAULT	0	V _{CC} +0.5	V	LVTTTL
Receiver SIGNAL DETECT Logic HIGH State	Rx_SD	0	V _{CC} +0.5	V	LVTTTL
Receiver RESET Logic HIGH State	Rx_RESET	0	V _{CC} +0.5	V	LVTTTL
I ² C Serial Data Logic HIGH State	SDA	-	V _{CC} +0.5	V	LVTTTL
I ² C Serial Clock HIGH State	SCL	-	V _{CC} +0.5	V	LVTTTL

Transmitter Electrical Specifications						
Parameter	Symbol	Min	Typ	Max	Units	Conditions / Notes
Tx DC Supply Current	I _{CC}	-	-	150	mA	
Tx_Data Differential Input Voltage	V _{IH-VIL}	300	-	1900	mV p-p	LVPECL Tx_DATA Electrical Signal
Tx_DIS = HIGH (Transmitter OFF / DISABLED)	V _{IH}	2.0	-	V _{CC} +0.3	V	LVTTTL (Control INPUT)
Tx_DIS = LOW (Transmitter ON / ENABLED)	V _{IL}	0	-	0.8	V	LVTTTL (Control INPUT)
Tx_FAULT = HIGH (Laser OFF / FAULT Condition)	V _{OH}	2.0	-	V _{CC} +0.3	V	LVTTTL (Monitor OUTPUT)
Tx_FAULT = LOW (Laser ON / NORMAL)	V _{OL}	0	-	0.8	V	LVTTTL (Monitor OUTPUT)

Receiver Electrical Specifications						
Parameter	Symbol	Min	Typ	Max	Units	Conditions / Notes
Rx DC Supply Current	I _{RX}	-	-	125	mA	Not Including the Output Load Current
Rx_Data Differential Output Voltage	V _{IH-VIL}	600	-	1900	mV p-p	LVPECL Rx_DATA Electrical Signal
Rx_SD = HIGH (Receiver ON / NORMAL)	V _{OH}	2.0	-	V _{CC} +0.3	V	LVTTTL (Monitor OUTPUT)
Rx_SD = LOW (Receiver OFF / LOSS OF SIGNAL)	V _{OL}	0	-	0.8	V	LVTTTL (Monitor OUTPUT)
Rx_RESET = HIGH (Receiver RESET)	V _{IH}	2.4	-	V _{CC} +0.3	V	LVTTTL (Control Input)
Rx_RESET = LOW (Receiver ON / NORMAL)	V _{IL}	0	-	0.8	V	LVTTTL (Control Input)

I ² C Serial Logic						
Parameter	Symbol	State	Logic	Min	Max	Units
I ² C Serial Data	SDA	HIGH	LVTTTL	2.0	V _{CC} +0.3	V
	SDA	LOW	LVTTTL	0	0.8	V
I ² C Serial Clock	SCL	HIGH	LVTTTL	2.0	V _{CC} +0.3	V
	SCL	LOW	LVTTTL	0	0.8	V



Transmitter Optical Specification						
Parameter	Symbol	Min	Typ	Max	Units	Conditions / Notes
Transmitter Type		1490 nm DFB CW Mode				
Average Output Power (9/125 μ SMF)	P _{out}	-1	-	4	dBm	
Optical Output with Tx OFF	P _{out}	-	-	-45	dBm	
Optical Rise and Fall Time	t _r / t _f	-	500	600	ps	20% to 80%
Tx Wavelength	λ	1480	1490	1500	nm	
Spectral Line Width @ -20 dB	$\Delta\lambda$	-	-	1.0	nm	
Side Mode Suppression Ratio	SMSR	30	-	-	dB	
Extinction Ratio	ER	10	-	-	dB	
Relative Intensity Noise	RIN	-	-	-118	dB/Hz	
Optical Return Loss	RL	-	-	15	dB	
Total Jitter	T _J	-	-	0.2	UI	
Optical Cross Talk	C _{RT}	-	40	-	dB	

Receiver Optical Specifications						
Parameter	Symbol	Min	Typ	Max	Units	Conditions / Notes
Receiver Type		1310 nm APD/TIA Burst Mode				
Optical Signal Indicator		Signal Detect				
Wavelength	λ	1260	1310	1360	nm	
Received Optical Power	P _{in}	-33	-	-8	dBm	BER<10 ⁻¹⁰ , 155.52 Mb/s, PRBS 2 ²³ -1
Maximum Input Optical Power	P _{in(max)}	-	-	-8	dBm	
Receiver Reflectance	RFL	-	-	-20	dB	
Receiver Settling Time	t _{rx}	-	-	200	ns	
Rx_Signal Detect Assert	P _a	-42	-	-33	dBm	
Rx_Signal Detect Deassert	P _d	-42.5	-	-33.5	dBm	
Rx_Signal Detect Hysteresis	P _{hy}	0.5	-	5	dB	

Eye Diagram

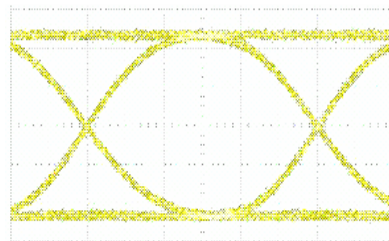

Transmitter Test Conditions

- Optical Output Power = 0 dBm
- Test Pattern = 2²³-1 NRZ PRBS

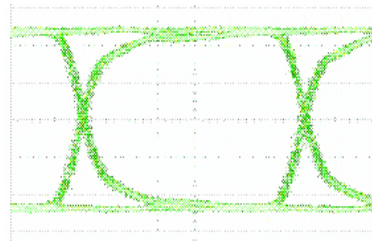

Receiver Test Conditions

- Optical Input Power = -20 dBm
- Test Pattern = 2²³-1 NRZ PRBS



Ligent

intelligent photonics

LTB3443 622 Mbps Tx / 155 Mbps Rx P2MP OLT 2x10 SFF B-PON Class B Transceiver

LTB3443 I2C Memory Map (Page A0 HEX, UNLISTED FIELDS ARE BLANK / EMPTY)							
Address		Memory Contents		Description	Name of Field	SFP MSA Reference	Notes
Decimal	HEX	ASCII	HEX				
0	00	002	02	Module is soldered to PCB	Identifier	Table 3.2	
1	01	004	04	Non Standard GBIC Interface	Extended Identifier	Table 3.3	
2	02	128	80	Pigtail Fiber with SC/PC Connector	Connector Values	Table 3.4	LTB3443 C
2	02	129	81	Pigtail Fiber with SC/APC Connector	Connector Values	Table 3.4	LTB3443 B
2	02	130	82	Pigtail Fiber without Connector	Connector Values	Table 3.3	LTB3443 A
4	04	016	10	Intermediate Reach	Transceiver Codes	Table 3.5a	
5	05	032	20	OC-12 Intermediate Reach	Transceiver Codes	Table 3.5	
11	0B	003	03	NRZ Encoding	Encoding Codes	Table 3.6	
12	0C	006	06	Nominal 622 Mb/s Data Rate	Nominal Bit Rate		
14	0E	010	0A	Link Length in km Units = 20	9 micron fiber length		
15	0F	100	64	Link Length in 100 m Units = 100	9 micron fiber length		
20 to 35	14 to 23	XXX	XX	Vendor Name	"Ligent Photonics"		ASCII Format
40 to 48	28 to 30	XXX	XX	Vendor Part Number	"LTB3443 X"		ASCII Format
56 to 59	37 to 3B	XX	XX	Vendor Revision Number	Revision 1.4		
60	3D	014	0E	Wavelength = 1490 nm			
61	3E	090	5A	Wavelength = 1490 nm			
65	41	28	1C	Tx_DIS, Tx_FAULT, Rx_SD	Option Values	Table 3.6	
66	42	20	14	Maximum Bit Rate Tolerance			
67	43	20	14	Minimum Bit Rate Tolerance			
68 to 83	44 to 53	XXX	XX	Vendor Serial Number	Ligent Serial Number		
84 to 91	54 to 5B	XXX	XX	Vendor Date Code	Ligent Date Code		



LTB3443 2x10 SFF Interface (Bottom View)

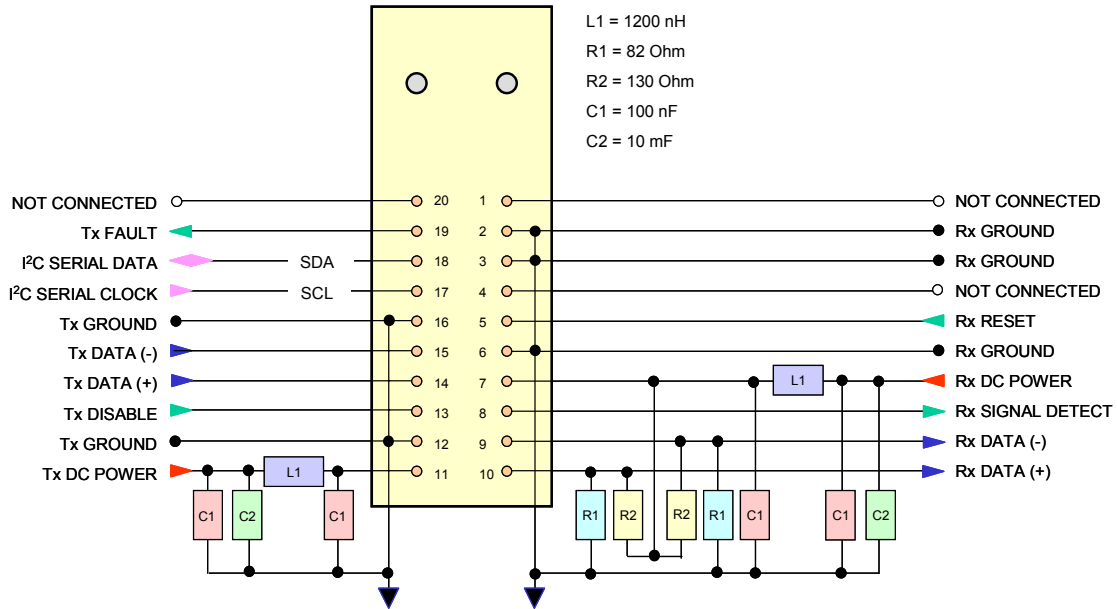

2x10 SFF PIN ASSIGNMENT

Pin	Symbol	Description	Pin	Symbol	Description
1	N/C	Not Connected	20	N/C	Not Connected
2	V _{EER}	Receiver Ground	19	Tx_Fault	Transmitter Fault (LVTTTL)
3	V _{EER}	Receiver Ground	18	SDA	I2C Serial Data (LVTTTL)
4	N/C	Not Connected	17	SCL	I2C Serial Clock (LVTTTL)
5	Rx_RESET	Receiver Burst Mode Reset (LVTTTL)	16	V _{EET}	Transmitter Ground
6	V _{EER}	Receiver Ground	15	TD-	Tx_DATA Inverted Differential Input (AC-Coupled)
7	V _{CCR}	Receiver +3.3 VDC Power Supply	14	TD+	Tx_DATA Non Inverted Differential Input (AC-Coupled)
8	Rx_SD	Receiver SIGNAL DETECT (LVTTTL)	13	Tx_DIS	Transmit Disable (LVTTTL)
9	RD-	Rx_DATA Inverted Differential Output DC-Coupled)	12	V _{EET}	Transmitter Ground
10	RD+	Rx_DATA Non Inverted Differential Output (DC-Coupled)	11	V _{CCT}	Transmitter +3.3 VDC Power Supply
Mounting Posts	The mounting posts are provided for mechanically attaching the transceiver to the circuit board. They should not be connected to the circuit ground but can be connected to the chassis ground.				
Housing Leads	The housing leads should be connected to circuit ground				



Eye Safety

The transceiver is a Class 1 eye-safe device according to FDA 21CFR1040.10 and 1040.11, IEC 60825-1 and IEC 60825-2.

Electromagnetic Interference (EMI), Immunity and Product Safety

The transceiver is ESD safe (electrical pins) when tested according to MIL-STD-883, Method 3015.4 and ESD safe (optical connector) when tested according to IEC 61000-4-2. The device is immune to strong RF fields when tested in accordance with IEC 610004-3. The device complies with (US) FCC, Part 15, Subpart J; (Europe) CENELEC EN 55022; (Canada) Class B (CISPR22A); and (Japan) VCCI Class 1. The device has been designed to conform to product safety requirements including UL1950, CSA 22.2, and IEC 60950, and has been designed to meet the flammability requirements of UL94.

Notice

The factory has made all adjustments to this device prior to shipment. No adjustments or modifications to the device are required or permitted. Any adjustment, modification or tampering of the device voids the product warranty. The US Food and Drug Administration may consider that any adjustment or modification to this device is an act of manufacturing and therefore will require that the device be recertified in accordance with 21 CFR 1040.10 Subpart j.

Required Label and Laser Emission

This device is labeled in accordance with FDA and IEC requirements for laser safety.

Required Label

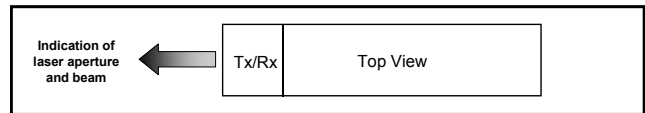

Laser Emission

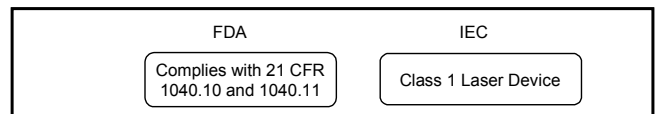

Laser Radiation Information	
Wavelength	1490 nm
FDA Total Optical Pout: 7 mm aperture at 20 cm distance	< 790 microwatts
IEC Total Optical Pout: 7 mm aperture at 14 cm distance	< 10000 microwatts
Beam Divergence	17.25°

LTB3443 Block Diagram

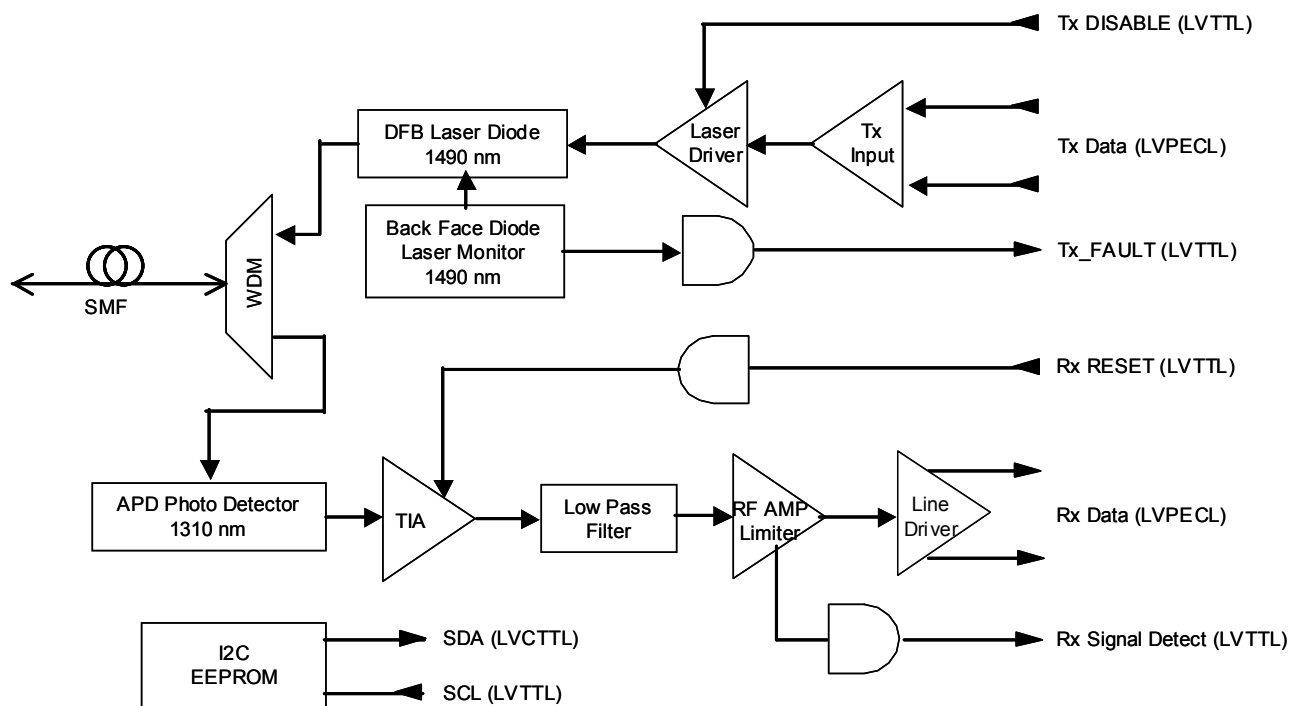



Ligent

intelligent photonics

LTB3443 622 Mbps Tx / 155 Mbps Rx P2MP OLT 2x10 SFF B-PON Class B Transceiver

Ligent Sales Offices

Ligent Photonics

2701 Dukane Drive
Suite 200
St. Charles, IL 60174
PH (630) 513-7226
FX (630) 513-9173
WS www.ligentphotonics.com

Ligent Photonics

(Virginia Sales Office)
8210 Strathmore Lane
Roanoke, VA 24019
PH (540) 797-5793
FX (540) 366-5793
WS www.ligentphotonics.com

Bitel Technologies LTD

Nur Building
43 Ha'Atzmaut Way
PO BOX 94
Yehud, 56302, Israel
PH +(972) 3-6322655
FX +(972) 3-6322279
WS www.bitel.co.il

Gigatron Associates

968 St. Laurent Boulevard
Ottawa, Ontario K1K 3B3
PH (613) 747-3472
FX (613) 747-3474
WS www.gigatron.com

Gigatron Associates

56 Bartleman Crescent
Cambridge, ON
PH: (519) 220-1856
FX: (510) 220-1938
WS: www.gigatron.com

Gigatron Associates

450 Avenue Racine PH #5
Dorval, QB H9S 3K8
PH: (514) 984-2598
FX: (514) 620-7812
WS: www.gigatron.com

Gigatron Associates

2388 Eversyde Avenue SW
Calgary, AB T2Y 4X6
PH: (403) 257-0636
FX: (403) 257-0569
www.gigatron.com

Gigatron Associates

406-838 Agnes Street
New Westminster, BC V3M 6R3
PH: (604) 787-2340
FX: (604) 787-2343
WS: www.gigatron.com

New Age Electronics

3000 Northwood's Parkway
Suite 280
Norcross, GA 30071
PH (770) 242-8800
FX (770) 242-8180
WS www.newagelec.com

New Age Electronics

8376 Six Forks Road
Suite 202
Raleigh, NC 27615
PH (919) 866-0620
FX (919) 866-0621
WS www.newagelec.com

New Age Electronics

4900 Corporate Drive
Suite B
Huntsville, AL 35805
PH (256) 430-8000
FX (256) 430-8414
WS www.newagelec.com

New Age Electronics

182 Sunset Drive
Mt. Dora, FL 32757
PH: (352) 735-6101
FX: (352) 735-6116
WS: www.newagelec.com

New Age Electronics

100 SE 5th Court
Suite 37
Pompano Beach, FL 33060
PH: (407) 804-1210
FX: (954) 928-2889
WS: www.newagelec.com

KJS Marketing

PO Box 72
Crystal Lake, IL 60039
PH (815) 788-1002
FX (815) 788-1004
WS www.kjsmarketing.com

KJS Marketing

7872 Olive Lane North
Maple Grove, MN 55311
PH (763) 391-6557
FX (763) 391-6554
WS www.kjsmarketing.com

KJS Marketing

2A Street
Lake Lotawana, MO 64086
PH (816) 578-4751
FX (816) 774-2571
WS www.kjsmarketing.com

KJS Marketing

1802 Hammer Drive, NW
Cedar Rapids, IA 52405
PH (319) 265-8592
FX (319) 265-8593
WS www.kjsmarketing.com

KJS Marketing

PO Box 1521
Maryland Heights, MO 63043
PH (314) 469-4544
FX (314) 469-4535
WS www.kjsmarketing.com

KJS Marketing

154 Struckman Blvd
Bartlett, IL 60103
PH (630) 289-4548
FX (630) 289-3778
WS www.kjsmarketing.com

Kruvand Associates

1202 Richardson Drive
Suite 113
Richardson, TX 75080
PH (972) 437-3355
FX (972) 680-8854
WS www.kruvand.com

Kruvand Associates

8100 Shoal Creek Boulevard
Suite 250
Austin, TX 75080
PH (512) 454-1111
FX (512) 454-9858
WS www.kruvand.com

Kruvand Associates

10601 Grant Road
Suite 104
Houston, TX 77070
PH (713) 956-6741
FX (713) 972-680-8854
WS www.kruvand.com

K-Tech Sales

100 Century Center Court
Suite 405
San Jose, CA 95112
PH (408) 437-1808
FX (408) 437-1883
WS www.ktechsales.com