



Ligent

intelligent photonics

LTB3434 155 Mb/sec P2MP ONU 2X5 SFF B-PON Transceiver, 20 km

The LTB3434 B-PON ONU transceiver module has been designed for low cost point to multi point (P2MP) Fiber to the Home, Business or Curb (FTTX) systems employing high-speed burst mode TDM receivers/transmitters in 155 Mb/sec symmetrical duplex data links. The device is based on the ITU-T G.983.1 and G.983.3 PON specification for bi-directional communications over a single fiber and incorporates a high performance 1310 nm Burst mode F-P transmitter and 1490 nm CW mode P-I-N receiver. It is capable of serving up to 16 subscribers in advanced TDM P2MP FTTH equipment over distances of up to 20 km. The LVTTTL compatible Tx Disable feature controls the laser transmitter and the signal detect feature provides an indication of the status of the receiver. The industry standard 2x5 small form factor (SFF) package incorporates a pigtail fiber with SC/APC or SC/PC connector, and is fabricated with a rugged die cast metal housing and cage assembly and operates over the extended temperature range from -40 to +85 degrees Centigrade.



Applications

- Access Networks
- Fiber to the Home, Curb, Office (FTTx)
- Point to Multi Point Service (P2MP)

Features

- Single fiber, full duplex operation
- Single 3.3 volt DC supply
- Dual wavelength (WDM) bi-directional transmission

- 1310 nm 155 Mb/s burst mode transmitter
- 1490 nm 155 Mb/s CW mode receiver
- ITU-T G.983.1 and G.983.3 PON compliant
 - Internal Tx automatic power control (APC)
- Differential LVPECL interface:
 - Data Input / Data Output

- Bias Control
- Single Ended LVTTTL control interface:
 - Tx disable
 - Rx Alarm
- Operating temperature range:
 - Commercial: 0 to 70 °C
 - Extended: -10 to 80°C
 - Industrial: -40 to +85 °C

Recommended Operating Conditions					
Parameter	Sym-	Min	Typ	Max	Units
Ambient Operating Tem-	T _{amb}	-40	25	+85	°C
DC Supply Voltage	V _{CC}	3.135	3.3	3.465	Volts
Module Supply Current	I _{IN}	-	150	200	mA
Module Power Dissipation	P _D	-	500	700	mW
Signaling Speed +/- 100	S	-	1.25	-	GBd
Useful Reach (16:1 Split)	D	-	10	-	km
Useful Reach (8:1 Split)	D	-	20	-	km
Tx_DIS ON to OFF Burst	t _{OFF}	-	10	12	ns
Tx_DIS OFF to ON Burst	t _{ON}	-	10	12	ns

Ordering Information				
Part Number	Package Option (X)		Temperature Option (Y)	
LTB3434 XY	A	Pigtail, no connector	C	Commercial
	B	Pigtail, SC/APC	E	Extended
	C	Pigtail, SC/PC	H	Industrial

LTB3434 2X5 SFF Interface

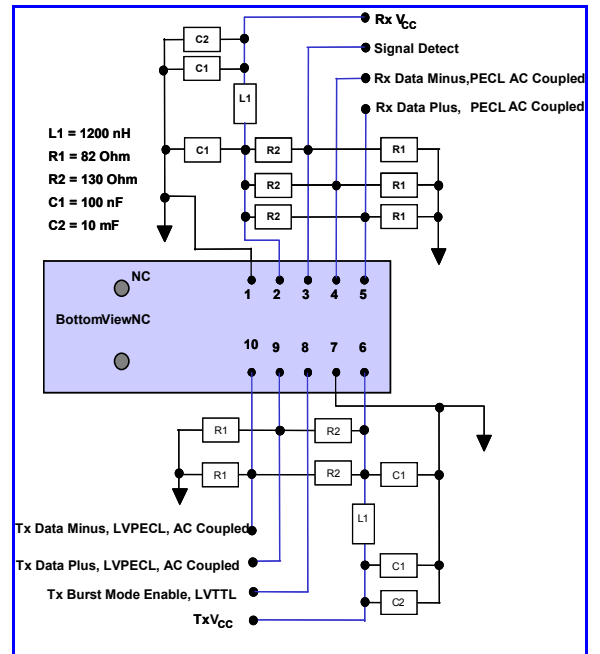



Absolute Maximum Ratings					
Parameter	Symbol	Min	Max	Units	Notes
Storage Temperature	T_{stg}	-40	+85	°C	Exceeding the Absolute Maximum Ratings may cause irreversible damage to the device.
Operating Temperature	T_O	-40	+85	°C	
Relative Humidity - Storage	RH_S	0	95	%	
Relative Humidity - Operating	RH_O	0	85	%	The device is not intended to be operated under the condition of simultaneous Absolute Maximum Ratings, a condition which may cause irreversible damage to the device.
DC Supply Voltage	V_{CC}	0	3.6	V	
Soldering Temperature	T_{slid}	0	260	°C	
Soldering Duration	t_{slid}	0	10	sec	

Absolute Maximum Ratings: Control Function Logic Levels					
Tx_DISABLE Logic HIGH State	Tx_DIS	-	$V_{CC}+0.5$	V	LVTTTL
Signal Detect Logic HIGH State	Rx_SD	-	$V_{CC}+0.5$	V	LVTTTL

Transmitter Electrical Specifications						
Parameter	Symbol	Min	Typ	Max	Unit	Conditions / Notes
Tx DC Supply Current	I_{CC}	-	-	150	mA	
Tx_Data Differential Input Voltage	V_{IH}, V_{IL}	300	-	-	mV p-p	LVPECL Tx_DATA Electrical Signal
Tx_DIS = HIGH (Transmitter ON)	V_{OH}	2.4	-	3.3	V	LVTTTL
Tx_DIS = LOW (Transmitter OFF)	V_{OL}	0	-	0.8	V	LVTTTL

Receiver Electrical Specifications						
Rx DC Supply Current	I_{RX}	-	-	125	mA	
Rx_Data Differential Output Voltage	V_{IH}, V_{IL}	600	-	1900	mV p-p	
Rx_Data Output Rise / Fall Time	t_r / t_f	-	1	2	ns	20% to 80%

LTB3434 Block Diagram

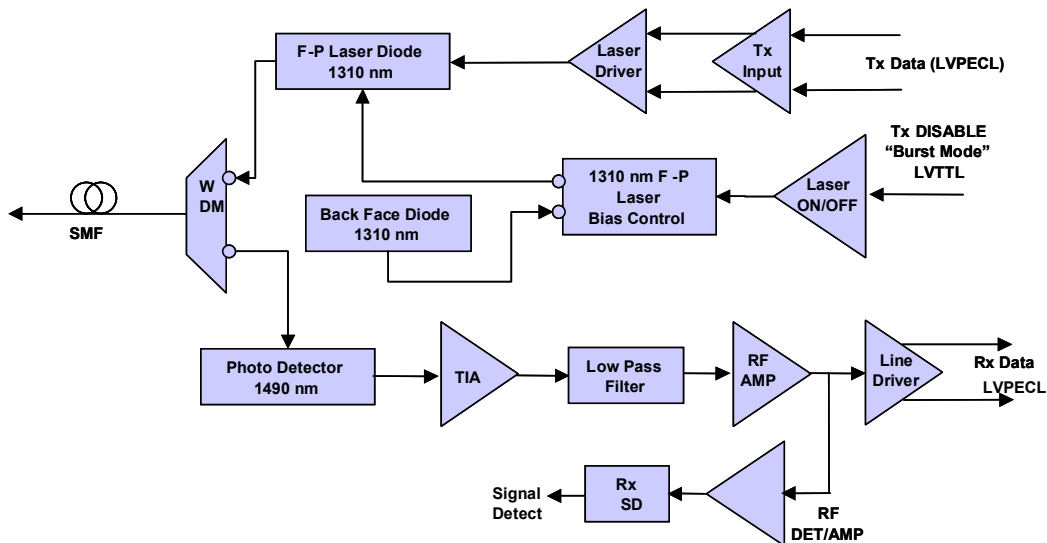



Transmitter Optical Specification

Parameter	Symbol	Min	Typ	Max	Units	Conditions / Notes
Transmitter Type		1310 nm F-P Burst Mode				
Average Output Power (9/125 μ SMF)	P _{out}	-5	-	2	dBm	
Optical Output with Tx OFF	P _{out}	-	-	-45	dBm	
Optical Rise and Fall Time	t _r / t _f	-	1	2	ns	20% to 80%
Tx Wavelength	λ	1260	1310	1360	nm	
Spectral Line Width	Δλ	-	-	3.5	nm	IEEE 802.3ah Compliant
Extinction Ratio	ER	8.2	10	-	dB	
Transmitter Output Eye (Jitter)	-	-	-	-	-	IEEE 802.3ah Compliant
Relative Intensity Noise	RIN	-	-	-113	dB/Hz	
Optical Return Loss	RL	-	-	15	dB	
Total Jitter	T _j	-	-	0.2	UI	
Optical Cross Talk	C _{RT}	-	40	-	dB	
Transmit Reflectance	RFL	-	-	-12	dB	

Receiver Optical Specifications

Parameter	Symbol	Min	Typ	Max	Units	Conditions / Notes
Receiver Type		1490 nm P-I-N/TIA CW Mode				
Optical Signal Detect		Signal Detect				
Wavelength	λ	1480	1490	1500	nm	
Received Optical Power	P _{in}	-34	-	-3	dBm	BER<10 ⁻¹⁰ , 1250 Mb/s, PRBS 2 ²³ -1
Maximum Input Optical Power	P _{in(max)}	-	-	4	dBm	Damage Threshold
Receiver Reflectance	RFL	-	-	-12	dB	
Stressed Receiver Sensitivity	P _{in}	-	-	-32	dBm	
Vertical Eye Closure Penalty	VEP	1.5	-	-	dB	

Eye Diagram

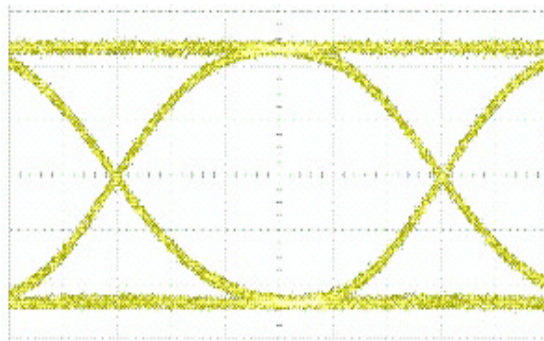

- Transmitter Test Conditions**
- Optical Output Power = 0 dBm
 - Test Pattern = 2²³-1 NRZ PRBS

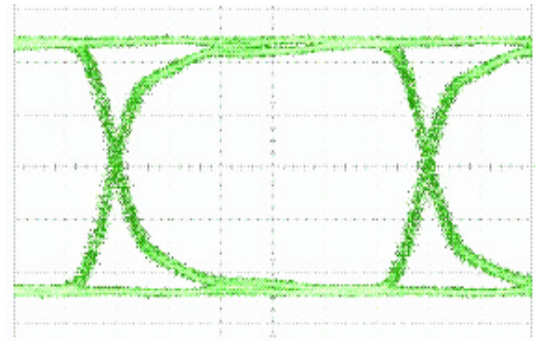

- Receiver Test Conditions**
- Optical Input Power = -20 dBm
 - Test Pattern = 2²³-1 NRZ PRBS



Transmitter Burst Mode

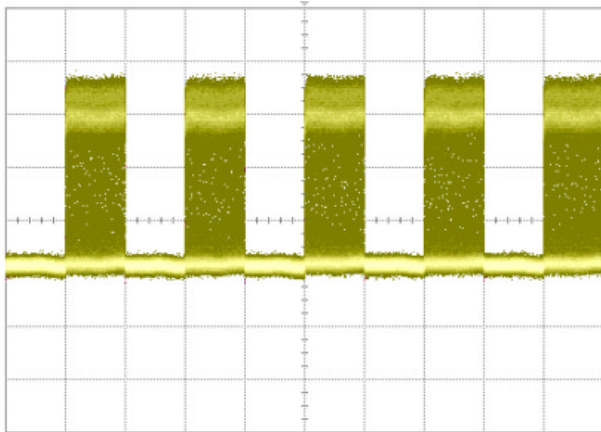

5 µs / Division

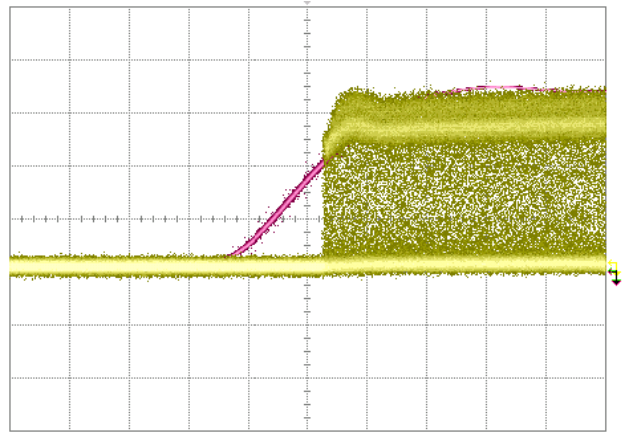

10 ns / Division

2 x 5 SFF Outline Drawing (Fiber Pigtail)

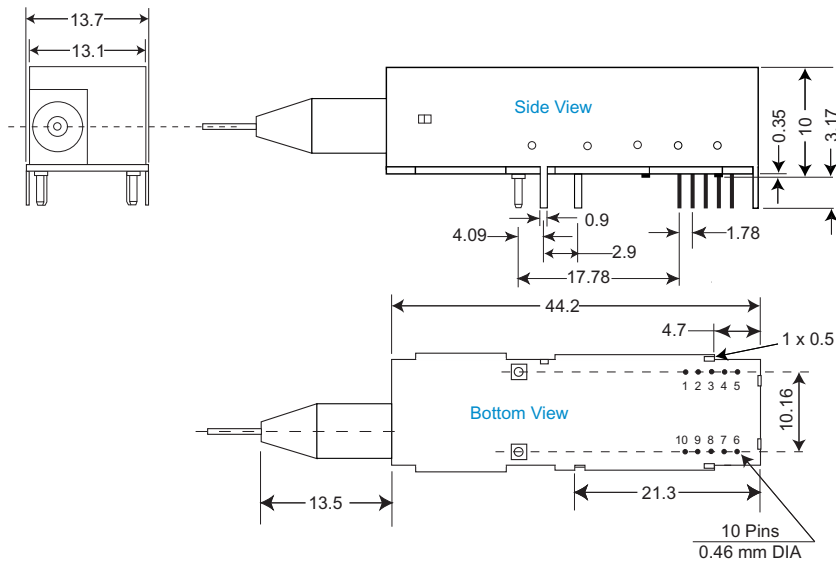



SFF PIN ASSIGNMENT		
Pin	Sym-	Description
1	V _{EER}	Receiver Signal Ground
2	V _{CCR}	+3.3 Volt Receiver Power Supply
3	Rx_SD	CW Mode Receiver Signal Detect
4	RD-	Rx Data - Inverted Differential Output
5	RD+	Rx Data - Non Inverted Differential Output
6	V _{CCT}	+3.3 Volt Transmitter Power Supply
7	V _{EET}	Transmitter Signal Ground
8	Tx_DIS	Burst Mode Transmitter Disable
9	TD+	Tx Data - Non Inverted Differential Input
10	TD-	Tx Data - Inverted Differential Input
Mounting Posts	The mounting posts are provided for mechanically attaching the transceiver to the circuit board. They should not be connected to the circuit ground but can	
Housing	The housing leads should be connected to circuit	

Eye Safety

The transceiver is a Class 1 eye-safe device according to FDA 21CFR1040.10 and 1040.11, IEC 60825-1 and IEC 60825-2.

Electromagnetic Interference (EMI), Immunity and Product Safety

The transceiver is ESD safe (electrical pins) when tested according to MIL-STD-883, Method 3015.4 and ESD safe (optical connector) when tested according to IEC 61000-4-2. The device is immune to strong RF fields when tested in accordance with IEC 61000-4-3. The device complies with (US) FCC, Part 15, Subpart J; (Europe) CENELEC EN 55022; (Canada) Class B (CISPR22A); and (Japan) VCCI Class 1. The device has been designed to

Required Label and Laser Emission

This device is labeled in accordance with FDA and IEC requirements for laser safety.

Required Label

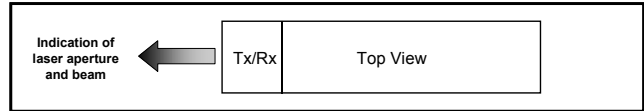

Laser Emission

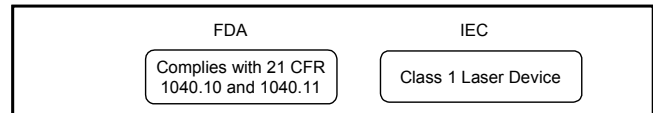

Laser Radiation Information	
Wavelength	1310 nm
FDA Total Optical Pout : 7 mm aperture at 20 cm distance	< 195 microwatts
IEC Total Optical Pout: 7 mm aperture at 14 cm distance	< 15,600 microwatts
Beam Divergence	17.25°

conform to product safety requirements including UL1950, CSA 22.2, and IEC 60950, and has been designed to meet the flammability requirements of UL94.

Notice

The factory has made all adjustments to this device prior to shipment. No adjustments or modifications to the device are required or permitted. Any adjustment, modification or tampering of the device voids the product warranty. The US Food and Drug Administration may consider that any adjustment or modification to this device is an act of manufacturing and therefore will require that the device be recertified in accordance with 21 CFR 1040.10 Subpart j.

Ligent Sales Offices

Ligent Photonics, Inc.
2701 Dukane Drive
Suite 200
St. Charles, IL 60174
PH (630) 513-7226
FX (630) 513-9173
WS www.ligentphotonics.com

Ligent Photonics, Inc.
(Virginia Sales Office)
8210 Strathmore Lane
Roanoke, VA 24019
PH (540) 797-5793
FX (540) 366-5793
WS www.ligentphotonics.com

New Age Electronics
3000 Northwood's Parkway
Suite 280
Norcross, GA 30071
PH (770) 242-8800
FX (770) 242-8180
WS www.newagelec.com

New Age Electronics
8376 Six Forks Road
Suite 202
Raleigh, NC 27615
PH (919) 866-0620
FX (919) 866-0621
WS www.newagelec.com

New Age Electronics
4940 Corporate Drive
Suite B
Huntsville, AL 35805
PH (256) 430-8000
FX (256) 430-8414
WS www.newagelec.co

K-Tech Sales
100 Century Center Court
Suite 405
San Jose, CA 95112
PH (408) 437-1808
FX (408) 437-1883
WS www.ktechsales.com

Kruvand Associates
1202 Richardson Drive
Suite 113
Richardson, TX 75080
PH (972) 437-3355
FX (972) 680-8854
WS www.kruvand.com

Kruvand Associates
8100 Shoal Creek Boulevard
Suite 250
Austin, TX 75080
PH (512) 454-1111
FX (512) 454-9858
WS www.kruvand.com

Kruvand Associates
10601 Grant Road
Suite 104
Houston, TX 77070
PH (713) 956-6741
FX (713) 972-680-8854
WS www.kruvand.com

VAL Technical Sales
183 Prospect Street
Hingham, MA 02043
PH (781) (781) 749-8358
FX (781) 740-4663
WS www.valtechnical.com