

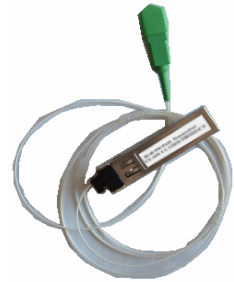

# LTB3422 1250 Mb/s PX-20 P2MP OLT Burst Mode 2x10 SFP E-PON Transceiver with APD, 20 km

The LTB3422 E-PON OLT transceiver module has been designed for low cost point to multi point (P2MP) Fiber to the Home, Business or Curb (FTTX) systems employing high-speed burst mode TDM receivers/transmitters in 1250 Mb/sec symmetrical duplex data links. The device is based on the IEEE 802.3ah 1000BASE PX-20 specification for bi-directional communications over a single fiber and incorporates a high performance 1310 nm sub-50 nanosecond burst mode APD Receiver and 1490 nm CW mode DFB transmitter. It is designed to serve up to 16 subscribers in advanced TDM P2MP FTTH equipment over distances of up to 20 km. It incorporates the SFP MSA LVTTTL Loss of Signal (Rx\_LOS), Tx Fault (Tx\_FAULT) and Tx Disable (Tx\_DIS) monitor and control functions, and is accessed via the I<sup>2</sup>C 2-wire serial ID interface (MOD\_DEF 0-1-2). The industry standard 2x10 small form pluggable (SFP) package incorporates a LC or SC duplex optical receptacle or pigtail fiber, is fabricated with a rugged die cast metal housing and cage assembly and operates over the temperature range from 0 to +70 degrees Centigrade.



### Applications

- Gigabit Ethernet Access Networks
- Fiber to the Home, Curb, Office (FTTx)
- Point to Multi Point Service (P2MP)
  - Up to 20 km Reach (16:1 Split)
  - Up to 10 km Reach (32:1 Split)

### Features

- Dual Wavelength Bi-Directional Tx/Rx
- Sub-50 Nanosecond Burst Mode Tx
- 1250 Mb/s Symmetrical Tx/Rx Data Rate
- 1310 nm APD/TIA Burst Mode Receiver
- 1490 nm CW Mode DFB Laser
- IEEE 802.3ah Compliant
- Single 3.3 Volt DC supply
- Low Power Consumption
- 2x10 SFP Package Outline
- Single Fiber, Full Duplex Operation
- Pigtail Optical Interface with Optional Connector
- Operating Temperature Range: 0 to +70 °C
- Data and Control Interfaces

- Tx Data LVPECL Differential
- Rx Data LVPECL Differential
- Tx\_DIS LVTTTL
- Tx\_FAULT LVTTTL
- Rx\_LOS LVTTTL
- 2-wire I<sup>2</sup>C data bus (MOD DEF 0, 1, 2)
  - BER <10<sup>-10</sup> (PRBS = 2<sup>23</sup>-1)
  - Internally AC coupled and terminated

Recommended Operating Conditions					
Parameter	Symbol	Min	Typ	Max	Units
Ambient Operating Temperature	T <sub>amb</sub>	0	25	+70	°C
DC Supply Voltage	V <sub>CC</sub>	3.135	3.3	3.465	Volts
Module Supply Current	I <sub>IN</sub>	-	150	200	mA
Module Power Dissipation	P <sub>D</sub>	-	500	700	mW
Signaling Speed +/- 100 ppm	S	-	1.25	-	GBd
Useful Reach (32:1 Split)	D	-	10	-	km
Useful Reach (16:1 Split)	D	-	20	-	km

Ordering Information	
Part Number	Package Option (X)
<b>LTB3422 X</b>	A SMF Pigtail Without Connector
	B SMF Pigtail with SC/APC
	C SMF with SC/PC

LTB3422 2X10 SFP Interface

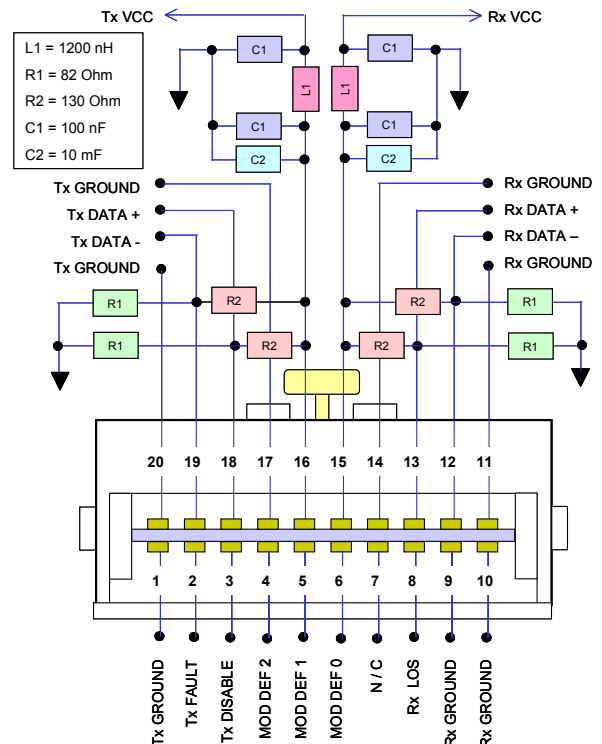



**Ligent**

intelligent photonics

# LTB3422 1250 Mb/s PX-20 P2MP OLT Burst Mode 2x10 SFP E-PON Transceiver with APD, 20 km

## Absolute Maximum Ratings

Parameter	Symbol	Min	Max	Units	Notes
Storage Temperature	$T_{stg}$	-40	+85	°C	Exceeding the Absolute Maximum Ratings may cause irreversible damage to the device.
Case Temperature	$T_{case}$	0	+70	°C	
Relative Humidity - Storage	RH <sub>S</sub>	0	95	%	
Relative Humidity - Operating	RH <sub>O</sub>	0	85	%	The device is not intended to be operated under the condition of simultaneous Absolute Maximum Ratings, a condition which may cause irreversible damage to the device.
DC Supply Voltage	$V_{CC}$	0	3.6	V	
Soldering Temperature	$T_{slid}$	0	260	°C	
Soldering Duration	$t_{slid}$	0	10	sec	

## Absolute Maximum Ratings: Optical and Electrical Signal Levels

8472 MOD_DEF 1 (Clock Signal Standard Mode)	SCL	100	-	kHz	
8472 MOD_DEF 1 (Clock Signal Fast Mode)	SCL	-	400	kHz	
Tx_DISABLE Logic HIGH State	Tx_DISABLE	0	$V_{CC}+0.5$	V	
Tx_FAULT Logic HIGH State	Tx_FAULT	0	$V_{CC}+0.5$	V	
Rx_LOS Logic HIGH State	Rx_LOS	0	$V_{CC}+0.5$	V	

## Transmitter Electrical Specifications

Parameter	Symbol	Min	Typ	Max	Unit	Conditions / Notes
Tx DC Supply Current	$I_{CC}$	-	-	150	mA	
Tx_Data Differential Input Voltage	$V_{IH}, V_{IL}$	600	-	1900	mV p-p	LVPECL Tx_DATA Electrical Signal
Tx_DISABLE = HIGH (Transmitter OFF)	$V_{OH}$	2.4	-	$V_{CC}+0.3$	V	LVTTTL
Tx_DISABLE = LOW (Transmitter ON)	$V_{OL}$	0	-	0.8	V	LVTTTL
Tx_FAULT = HIGH (Normal Operation)	$V_{OH}$	2.4	-	$V_{CC}+0.3$	V	LVTTTL
Tx_FAULT = LOW (Fault Condition)	$V_{OL}$	0	-	0.8	V	LVTTTL

## Receiver Electrical Specifications

Rx DC Supply Current	$I_{RX}$	-	-	125	mA	Not Including the Output Load Current
Rx_Data Differential Output Voltage	$V_{IH}, V_{IL}$	600	-	1900	mV p-p	LVPECL Rx_DATA Electrical Signal
Rx_Data Output Rise / Fall Time	$t_r / t_f$	-	150	260	ps	20% to 80%
Rx_LOS = HIGH (Receiver OFF)	$V_{OH}$	2.4	-	$V_{CC}+0.3$	V	LVTTTL
Rx_LOS = LOW (Receiver ON)	$V_{OL}$	0	-	0.8	V	LVTTTL

## LTB3422 Block Diagram

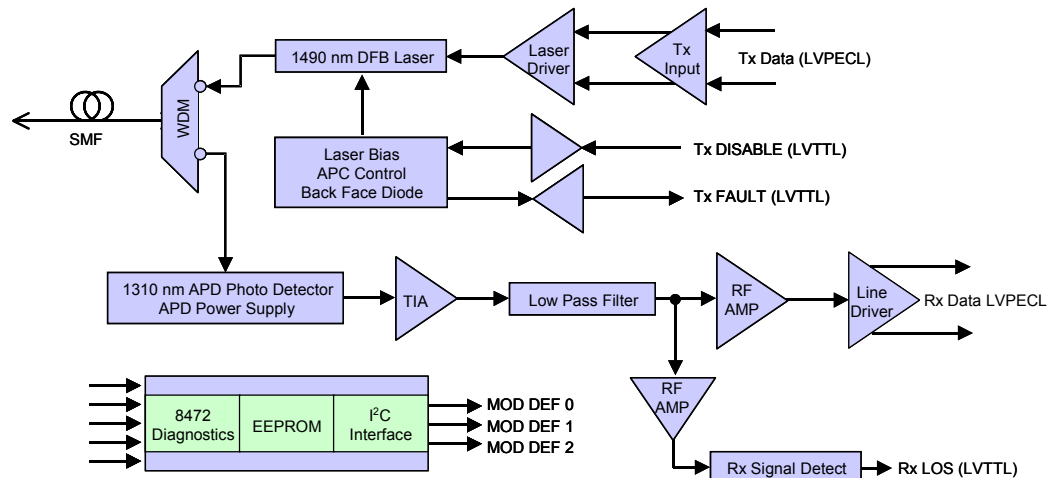



Transmitter Optical Specification						
Parameter	Symbol	Min	Typ	Max	Units	Conditions / Notes
Transmitter Type		1490 nm DFB CW Mode				
Average Output Power (9/125 $\mu$ SMF)	P <sub>out</sub>	+2.0	+3.0	+7.0	dBm	
Optical Output with Tx OFF	P <sub>out</sub>	-	-	-39	dBm	
Optical Rise and Fall Time	t <sub>r</sub> / t <sub>f</sub>	-	150	250	ps	20% to 80%
Tx Wavelength	$\lambda$	1480	1490	1500	nm	
Spectral Line Width @ -20dB	$\Delta\lambda$	-	-	0.44	nm	IEEE 802.3ah Compliant
Side Mode Suppression Mode	SMSR	30	-	-	dB	
Extinction Ratio	ER	6	9	-	dB	
Transmitter Output Eye (Jitter)	-	-	-	-	-	IEEE 802.3ah Compliant
Relative Intensity Noise	RIN	-	-	-118	dB/Hz	
Optical Return Loss	RL	-	-	15	dB	
Optical Return Loss of ODN	RL <sub>ODN</sub>	20	-	-	dB	
Total Jitter	T <sub>j</sub>	-	-	0.2	nsec	
Optical Cross Talk	C <sub>RT</sub>	-	40	-	dB	
Transmit Reflectance	RFL	-	-	-12	dB	
Transmit Dispersion Penalty	DP	-	-	2.3	dB	

Receiver Optical Specifications						
Parameter	Symbol	Min	Typ	Max	Units	Conditions / Notes
Receiver Type		1310 nm APD/TIA Burst Mode				
Wavelength	$\lambda$	1280	1310	1340	nm	
Received Optical Power	P <sub>in</sub>	-27	-	-6	dBm	BER<10 <sup>-10</sup> , 1250 Mb/s, PRBS 2 <sup>7</sup> -1
Maximum Input Optical Power	P <sub>in</sub> (max)	-	-	4	dBm	Damage Threshold
Receiver Sensitivity	P <sub>in</sub>	-	-	-27	dBm	
Rx_LOS Signal Threshold	Rx_LOS	-	-	-44	dBm	
Receiver Reflectance	RFL	-	-	-12	dB	
Stressed Receiver Sensitivity	P <sub>in</sub>	-	-	-24.4	dBm	
OMA Stressed Receiver Sensitivity	P <sub>in</sub>	-	-	-23.6	dBm	
Vertical Eye Closure Penalty	VEP	2.2	-	-	dB	
Receiver Settling Time	t <sub>rx</sub>	-	-	400	ns	

**Eye Diagram**

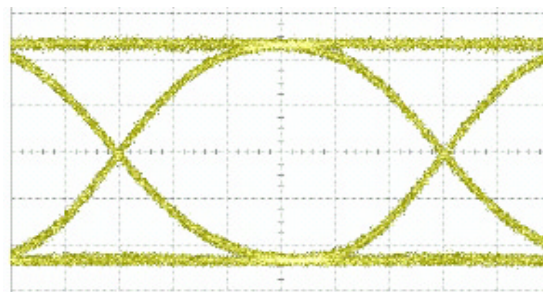

- Transmitter Test Conditions**
- Optical Output Power = 3 dBm
  - Test Pattern = 2<sup>7</sup>-1 NRZ PRBS

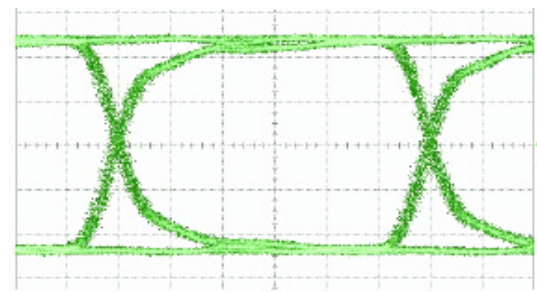

- Receiver Test Conditions**
- Optical Input Power = -20 dBm
  - Test Pattern = 2<sup>7</sup>-1 NRZ PRBS



**Transmitter Burst Mode**

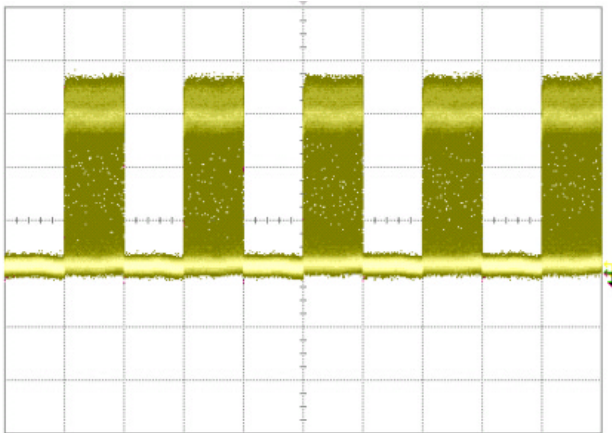

5 us / Division

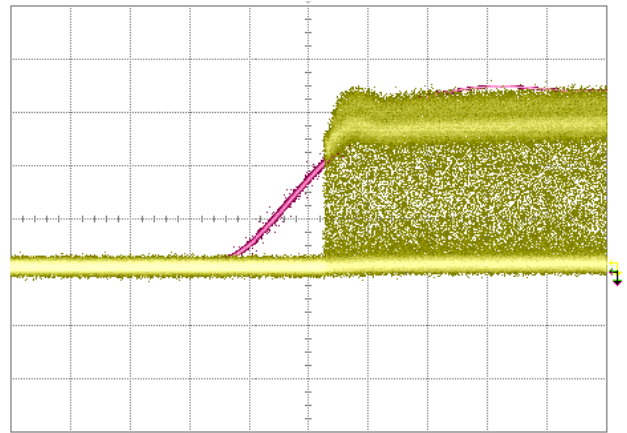

10 ns / Division

**SFP PIN ASSIGNMENT**

Pin	Symbol	Description	Pin	Symbol	Description
1	V <sub>EET</sub>	Transmitter Signal Ground	11	V <sub>EER</sub>	Receiver Ground
2	Tx_FAULT	LVTTTL Transmitter Fault (LOW = NORMAL, HIGH = FAULT)	12	RD <sub>-</sub>	CML Rx_Data Output (Inverted)
3	Tx_DIS	LVTTTL Transmitter Disable (LOW = NORMAL, HIGH = DISABLE)	13	RD <sub>+</sub>	CML Rx_Data Output (Non-Inverted)
4	MOD_DEF 2	LVTTTL I <sup>2</sup> C Serial Data (SDA)	14	V <sub>EER</sub>	Receiver Ground
5	MOD_DEF 1	LVTTTL I <sup>2</sup> C Serial Clock (SCL)	15	V <sub>CCR</sub>	Receive DC Input (3.3 Volts)
6	MOD_DEF 0	I <sup>2</sup> C Serial Data Bus Ground	16	V <sub>CCT</sub>	Transmit DC Input (3.3 Volts)
7	N/C	No Connection	17	V <sub>EET</sub>	Transmitter Ground
8	R_LOS	LVTTTL Receiver Loss of Signal (LOW = NORMAL, HIGH = LOS)	18	Tx_DATA (+)	LVPECL Differential Data (Non-Inverted)
9	V <sub>EER</sub>	Receiver Ground	19	Tx_DATA (-)	LVPECL Differential Data (Inverted)
10	V <sub>EER</sub>	Receiver Ground	20	V <sub>EET</sub>	Transmitter Ground
Note 1	The uncommitted Tx_FAULT, Tx_DIS, Rx_LOS, MOD_DEF 1 and MOD_DEF 2 monitor and control pins each require a pull-up resistor of 4700 to 10,000 Ohms				
Note 2	The 100 Ohm differential Rx_Data output is internally AC-coupled and must be terminated with 100 Ohms at the differential user interface				
Note 3	The 100 Ohm differential Tx_Data input is internally AC-coupled and terminated				



**Ligent**

intelligent photonics

**LTB3422 1250 Mb/s PX-20 P2MP OLT Burst Mode  
2x10 SFP E-PON Transceiver with APD, 20 km**

**SFP Outline (Fiber Pigtail)**

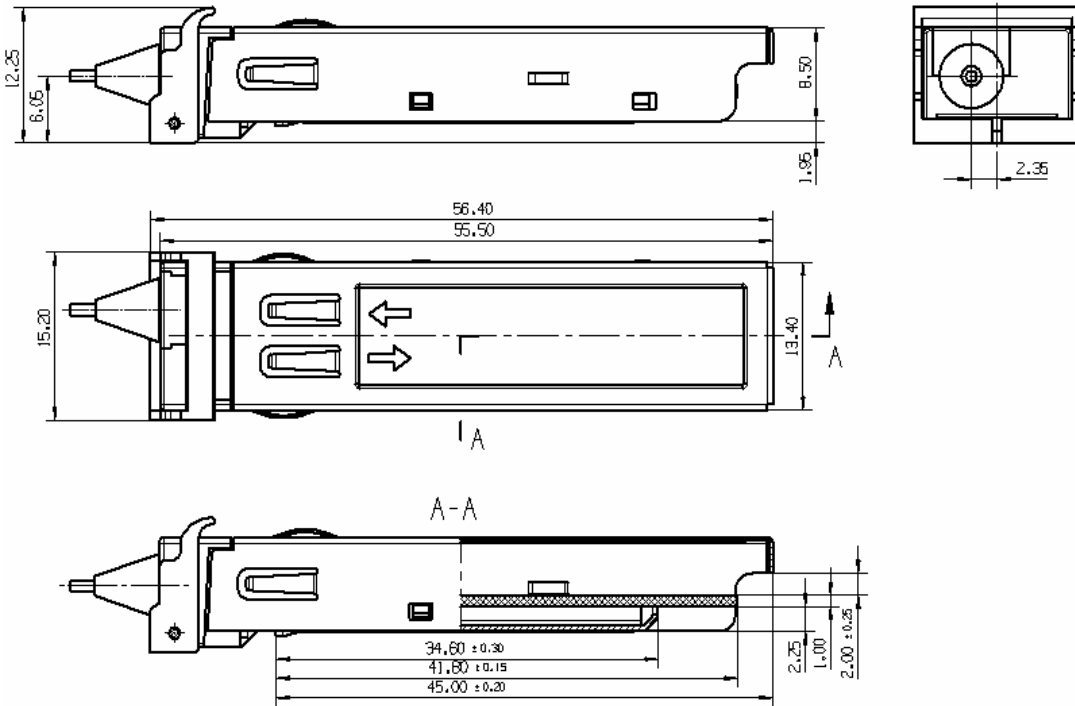



**Ligent**

intelligent photonics

# LTB3422 1250 Mb/s PX-20 P2MP OLT Burst Mode 2x10 SFP E-PON Transceiver with APD, 20 km

## Regulatory Information

### Eye Safety

The transceiver is a Class 1 eye-safe device according to FDA 21CFR1040.10 and IEC 60825-2.

### Electromagnetic Interference (EMI), Immunity and Product Safety

The transceiver is ESD safe (electrical pins) when tested according to MIL-STD-883, Method 3015.7 and ESD safe (optical connector) when tested according to IEC 61000-4-2. The device is immune to strong RF fields when tested in accordance with IEC 61000-4-3. The device complies with (US) FCC, Part 15, Subpart J; (Europe) CENELEC EN 55022; (Canada) Class B (CISPR22A); and (Japan) VCCI Class 1. The device has been designed to conform to product safety requirements including UL1950, CSA 22.2, and IEC 60950-1, and has been designed to meet the flammability requirements of UL94.

### Notice

The factory has made all adjustments to this device prior to shipment. No adjustments or modifications to the device are required or permitted. Any adjustment, modification or tampering of the device voids the product warranty. The US Food and Drug Administration may consider that any adjustment or modification to this device is an act of manufacturing and therefore will require that the device be recertified in accordance with 21 CFR 1040.10 Subpart j.

### Laser Radiation Information

Wavelength	1490 nm
FDA Total Pout: 7 mm aperture at 20 cm distance	< 790 microwatts
IEC Total Pout : 7 mm aperture at 10 cm distance	< 10000 microwatts
Beam Divergence	17.25°

### Required Label

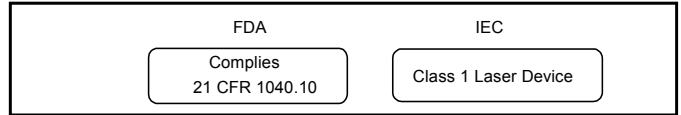

### Laser Emission

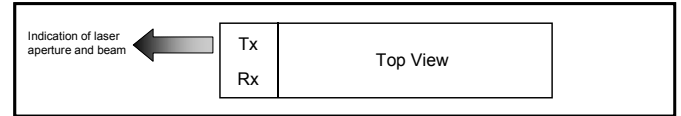

## Ligent Sales Offices - USA

### Ligent Photonics, Inc.

2701 Dukane Drive  
Suite 200  
St. Charles, IL 60174  
PH (630) 513-7226  
FX (630) 513-9173  
WS www.ligentphotonics.com

### Ligent Photonics, Inc.

(Virginia Sales Office)  
8210 Strathmore Lane  
Roanoke, VA 24019  
PH (540) 797-5793  
FX (540) 366-5793  
WS www.ligentphotonics.com

### New Age Electronics

3000 Northwood's Parkway  
Suite 280  
Norcross, GA 30071  
PH (770) 242-8800  
FX (770) 242-8180  
WS www.newagelec.com

### New Age Electronics

8376 Six Forks Road  
Suite 202  
Raleigh, NC 27615  
PH (919) 866-0620  
FX (919) 866-0621  
WS www.newagelec.com

### New Age Electronics

4940 Corporate Drive  
Suite B  
Huntsville, AL 35805  
PH (256) 430-8000  
FX (256) 430-8414  
WS www.newagelec.co

### K-Tech Sales

100 Century Center Court  
Suite 405  
San Jose, CA 95112  
PH (408) 437-1808  
FX (408) 437-1883  
WS www.ktechsales.com

### Kruvand Associates

1202 Richardson Drive  
Suite 113  
Richardson, TX 75080  
PH (972) 437-3355  
FX (972) 680-8854  
WS www.kruvand.com

### Kruvand Associates

8100 Shoal Creek Boulevard  
Suite 250  
Austin, TX 75080  
PH (512) 454-1111  
FX (512) 454-9858  
WS www.kruvand.com

### Kruvand Associates

10601 Grant Road  
Suite 104  
Houston, TX 77070  
PH (713) 956-6741  
FX (713) 972-680-8854  
WS www.kruvand.com

### VAL Technical Sales

183 Prospect Street  
Hingham, MA 02043  
PH (781) (781) 749-8358  
FX (781) 740-4663  
WS www.valtechnical.com

## Ligent Sales Offices - Asia

### Hisense Optoelectronics Technology Co., Limited

No.11, Jiangxi Road  
Qingdao, Shandong  
China 266071  
PH 86 (532) 601-0000  
FX 86 (532) 601-6007  
WS www.hisenseopto.com

### Summit Hisense Company, Limited

Triton Square  
Office Tower Z 19F 1-8-12  
Harumi Chuo-ku 104-6219  
Japan  
PH 81-3-5547-1252  
FX 81-3-5547-1268