

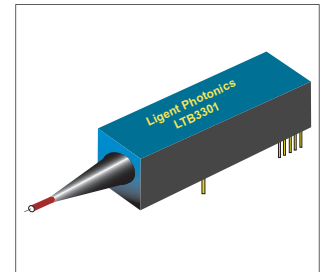

The LTB3301 bi-directional optical transceiver is ideally suited for 155 Mb/sec FSAN (Full Service Access Network) point-to-point Fiber to the Home equipment, or SONET/SDH OC-3, ATM, Fast Ethernet and PON applications where a single SMF fiber is required to simultaneously carry both Tx and Rx signals up to 20 km. A built-in high isolation WDM enables full duplex operation. It is mounted in the MSA compliant 2X5 small form factor (SFF) package with fiber pigtail. FC or MU optical connectors are standard options. The transmitter and receiver subassemblies incorporate a high performance 1310 nm MQW F-P laser assembly and high sensitivity 1310 nm PIN/TIA photo receiver with limiting amplifier. The differential AC coupled Tx and Rx data interfaces are LVPECL compatible; the single ended control and monitor functions include Rx_SD, which is LVPECL compatible and Tx_DISABLE, which is LVTTTL compatible. The device operates from a single 3.3-volt power supply and is designed for operation over the extended temperature range of -10° to $+70^{\circ}$ Centigrade. The Class I laser transmitter complies with international safety standards.



Applications

- Full Service Access Network (FSAN)
- Fiber to the Home (FTTH)
- ATM, SONET, OC-3

Features and Benefits

- Transmitter and receiver in a single compact package
- Tx/Rx distance up to 20 km
- Integral simplex SC connector
- Single +3.3V power supply
- 100 mA nominal Tx section DC current
- 120 mA nominal Rx section DC current
- Industry standard SFF 2x5 outline
- 1310 nm MQW F-P laser diode transmitter
- High sensitivity 1310 nm PIN/TIA receiver with limiter
- Cross talk > -30 dB
- Differential LVPECL input and output interface
- Single ended LVTTTL Tx DISABLE function
- Single ended LVPECL Rx SD Alarm function
- Wave solderable and aqueous washable package
- Operating temperature range -10 to $+70^{\circ}$ C

Laser Safety

This device incorporates a Class 1 laser source and complies with IEC 825, U.S. FDA 21, CFR 1040.10 and 1040.11 (accession number 0210091-00) regulations. It must be operated within the specified temperature and voltage limits. The module optical ports module must be terminated with an optical connector or dust plug. Any internal modification to the transceiver renders the device non-compliant, voids any warranties and could result in a health hazard.

Absolute Maximum Ratings

Parameter	Symbol	Min	Max	Units
Storage Temperature	Tstg	-40	+85	$^{\circ}$ C
Operating Temperature	Tamb	-10	+70	$^{\circ}$ C
DC Supply	VCC	0	4.5	Volts
Signal / Data Input Voltage	Vin	GND	Vcc	Volts
Signal / Data Output Current	Iout	-	30	mA

Typical Operating Characteristics (T = -10 to $+70^{\circ}$ C, VCC = 3.3 Volts)

Parameter	Symbol	MIN	TYP	MAX	Units
Power Supply	VCC	3.135	3.3	3.465	V
Bit Rate	-	-	155	170	Mb/sec
Transmitter Section (F-P Laser Transmitter)					
Optical Output (into 9/125 μ SMF)	Pout	-14	-	-8	dBm
Tx Wavelength	λ_{out}	1260	1310	1360	nm
RMS Spectral Line Width	$\Delta\lambda$	-	-	6	nm
Extinction Ratio	ER	10	-	-	dB
Output Eye (Telcordia/Bellcore)	TR-NWT-000253 and ITU-T G.957 compliant				
Tx optical rise / fall time (10 - 90 %)	tr	-	-	2	ns
Input Noise floor	Rin	-	-	-116	dB/Hz
Total Jitter	Tj	-	-	1	nsec
Signal / Data Input Current (LOW)	IIL	-350	-	-	μ A
Signal / Data Input Current (HIGH)	IiH	-	-	350	μ A
Differential Signal Input Voltage	VIH-VIL	300	-	-	mV p-p
Signal / Data Input Voltage (LOW)	VIL-VCC	-2	-	-1.58	V
Signal / Data Input Voltage (HIGH)	VIH-VCC	-1.1	-	-0.74	V
Receiver Section (PIN/TIA Receiver)					
Rx Optical Sensitivity	Pin	-	-	-31	dBm
Rx Operating Wavelength	λ_{in}	1260	1310	1360	nm
Rx Optical Pin Max	Pin MAX	-8	-	-	dBm
Signal Detect (ASSERT / Low to High)	Pa	-	-	-33	dBm
Signal Detect (DEASSERT / High to Low)	Pd	-43	-	-	dBm
Signal Detect Hysteresis	None	1	-	4	dB
Optical Return Loss	RL	14	-	-	dB
Signal Data Output Voltage - LOW	VIL-VCC	-2	-	-1.58	Volts
Signal Data Output Voltage - HIGH	VIH-VCC	-1.1	-	-0.74	Volts
Logic States: Tx ENABLE/DISABLE (LVTTTL); Rx SD (ECL 10K, 10KH, 100K, LVPECL)					
Tx ENABLE (Tx DIS = LOW)	Tx DISL	0	-	0.8	Volts
Tx DISABLE (Tx DIS = HIGH)	Tx DISH	VCC-1.3	-	VCC	Volts
Tx DISABLE shut off time	Tx DIS	-	-	1	msec
Rx SIGNAL DETECT (LOW)	VIL-VCC	-2	-	-1.58	Volts
Rx SIGNAL DETECT (HIGH)	VIH-VCC	-1.1	-	-0.74	Volts

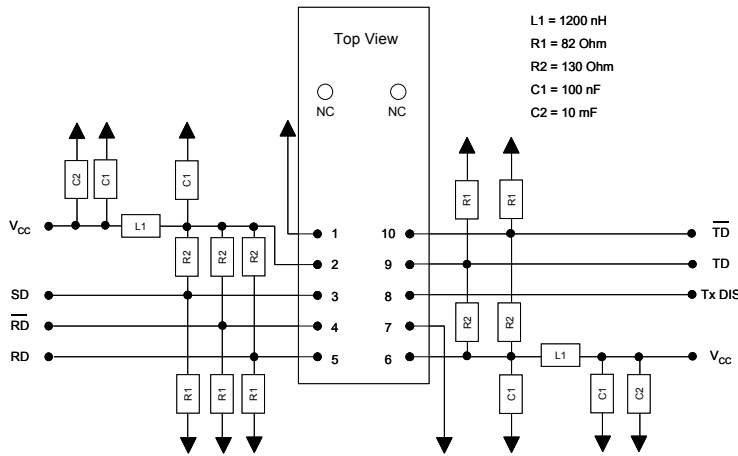

SFF 2X5 Bi-Directional Transceiver Pin Description

Pin	Name	Level	Notes
1	Vee		Rx -DC, Ground
2	Vcc		Rx +DC Supply
3	Rx_SD	LVPECL	HIGH = Normal; LOW = No Light
4	RDn	LVPECL	Rx Differential Data Out (-)
5	RDp	LVPECL	Rx Differential Data Out (+)
6	Vcc		Tx +DC Supply
7	Vee		Tx -DC, Ground
8	Tx_DIS	LVTTTL	LOW = Normal, HIGH = Tx Disable
9	TDp	LVPECL	x Differential Data In (+)
10	TDn	LVPECL	Tx Differential Data In (-)

Circuit Design Notes

- The circuit layout must minimize stray lead inductance that could generate unwanted (spurious) signals or unwanted RF oscillation.
- The input impedance for each phase of the differential input and output signals is 50 Ohms to ground (82 Ohms in parallel with 130 Ohms). The use of micro strip is recommended for each signal path.
- The parasitic inductance of leaded components may desensitize the receiver or reduce the transmitter drive signal ($R+j\omega L$). The use of high quality chip resistors and chip capacitors are recommended.
- High-Q chokes are recommended for DC power supply decoupling to prevent a feedback path that can lead to unwanted RF oscillation. A 10 mF tantalum electrolytic capacitor is recommended for pulse charge storage.
- A ground plane on the bottom of the PCB may reduce the possibility of unwanted spurious signals and improve the sensitivity of the receiver. Plated through holes are recommended to minimize parasitic lead inductance.

Bi-Directional Transceiver Block Diagram

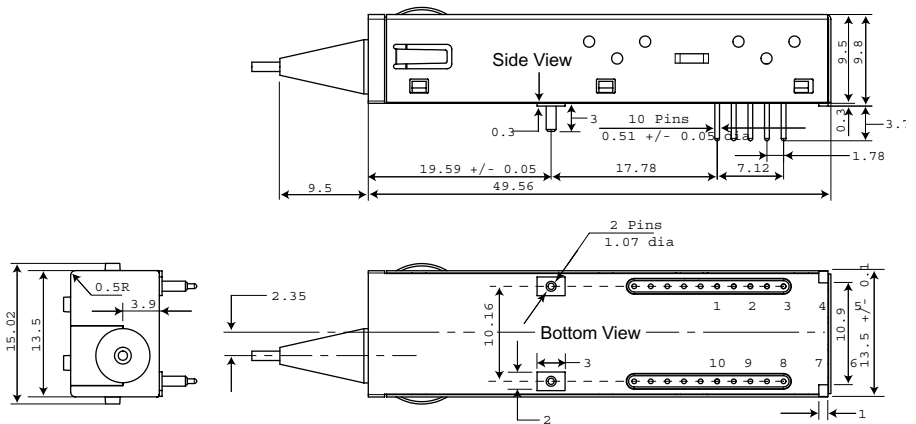
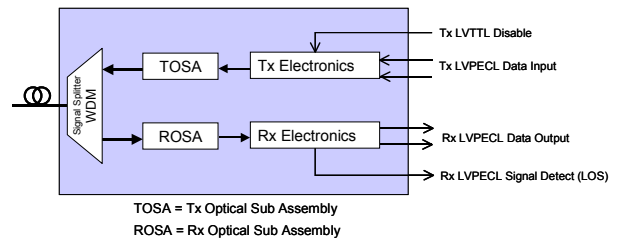

**Dimensions are in mm
Tolerances are ±0.01 mm**

How to Order

Part Number	Data Rate	Transmitter	Receiver	Reach	Temperature Range	Package Option
LTB3301 NC	155 Mb/sec	1310 nm / F-P	1310 nm	20 km	-10 to 70 °C	SMF Pigtail without Optical Connector
LTB3301 FC	155 Mb/sec	1310 nm / F-P	1310 nm	20 km	-10 to 70 °C	SMF Pigtail with FC/PC Optical Connector
LTB3301 MU	155 Mb/sec	1310 nm / F-P	1310 nm	20 km	-10 to 70 °C	SMF Pigtail with MU/PC Optical Connector