

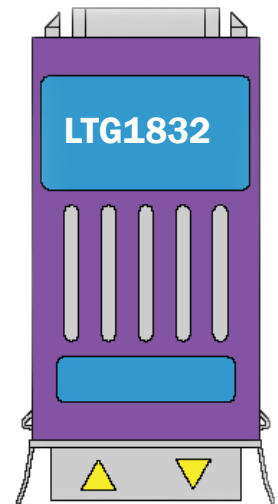

The LTG1832 series of CWDM GBIC transceivers are intended for 120 km reach service in high-speed Gigabit Ethernet or Fibre Channel (MOD-DEF-6) data communications communication equipment operating up to 1250 Mb/s where low-cost, extraordinary performance and reliability are essential. The 8 available CWDM wavelengths cover the band in 20 nm increments from 1470 nm to 1610 nm. They meet the requirements of IEEE 802.3z 1000BASE-LH, consume low power, incorporate the industry standard 2x10 GBIC metal package and are offered in the 0 to 70°C commercial temperature range. The low jitter and low bit error rate optical assemblies features a low noise high responsivity planar InGaAs PIN/TIA receiver and a high performance CWDM DFB laser transmitter. The control and monitor functions include Rx Loss of Signal, TX Fault, TX Disable and the digital diagnostic monitor feature which is accessed via the I²C 2-wire serial ID interface. The differential AC coupled TX and RX data interfaces are LVPECL compatible. The devices are Class I laser safety compliant.



Applications

- 1250 Mb/s CWDM Gigabit Ethernet
- 1062.5 Mb/s CWDM Fibre Channel
- Rack to rack system interconnects
- Metro / Access Networks
- Switch to switch interfaces
- Hub interconnects
- Bus extenders
- Channel extenders
- Host adapter interconnects
- Mass storage system interconnects
- Telecom switches
- Router interconnects

Features

- GBIC metal package
- 20-pin SCA-2 connector
- SC Duplex optical interface
- GBIC 8053 REV 5.5 compliant
- IEEE 802.3z 1000BASE-LH data links
- 120 km reach
- Up to 1250 Mb/s data rate
- 3.3 V or 5.0 V operation
- Low DC power consumption
- CWDM DFB laser (1470 nm to 1610 nm)
- High sensitivity APD/TIA optical receiver
- Single Mode operation
- BER < 1X10⁻¹² (2⁷ - 1 NRZ PRBS)
- 0 to 70°C operating temperature range:
- TTL Rx Loss of Signal monitor function
- TTL Tx Disable control function
- TTL Tx Fault monitor function
- TTL 2-wire I²C data bus
- Internally AC coupled and terminated
- LVPECL Rx and TX data interface
- 150 Ohms differential (line to line)
- 75 Ohms single ended (line to ground)

How to Order

Part Number	Lambda	Input / Output Coupling	DC Supply (V)	Rx SD	Rx DATA	Tx DIS	Tx FAULT	Tx DATA	I ² C
LTG18322-47	1470 nm	AC / AC	3.3 / 5.0 V	TTL	PECL	TTL	TTL	PECL	TTL
LTG1832-49	1490 nm	AC / AC	3.3 / 5.0 V	TTL	PECL	TTL	TTL	PECL	TTL
LTG1832-51	1510 nm	AC / AC	3.3 / 5.0 V	TTL	PECL	TTL	TTL	PECL	TTL
LTG1832-53	1530 nm	AC / AC	3.3 / 5.0 V	TTL	PECL	TTL	TTL	PECL	TTL
LTG1832-55	1550 nm	AC / AC	3.3 / 5.0 V	TTL	PECL	TTL	TTL	PECL	TTL
LTG1832-57	1570 nm	AC / AC	3.3 / 5.0 V	TTL	PECL	TTL	TTL	PECL	TTL
LTG1832-59	1590 nm	AC / AC	3.3 / 5.0 V	TTL	PECL	TTL	TTL	PECL	TTL
LTG1832-61	1610 nm	AC / AC	3.3 / 5.0 V	TTL	PECL	TTL	TTL	PECL	TTL



Absolute Maximum Ratings						
Parameter	Symbol	Min	Max	Units	Notes	
Storage Temperature	T _{STG}	-40	+85	°C		
Case Operating Temperature	T _{CASE}	0	+70	°C		
Relative Humidity - Storage	RH _S	0	95	%		
Relative Humidity - Operating	RH _O	0	85	%		
DC Supply Voltage	V _{CC}	0	6.0	V		
DC Supply Current	I _{CC}	-	400	mA		
Tx DATA DC Input Voltage	V _{IN}	-0.5	V _{CC} + 0.5	V		
Tx DATA Differential Input Voltage	V _{pk-pk}	300	1600	mV pk-pk		
Rx Optical Input Power	P _{IN-MAX}		0	dBm		
Rx DATA DC Output Current	I _{OUT}	-	50	mA		
Tx DISABLE Logic HIGH State	TX_DIS	-	V _{CC} +0.5	V		
Tx FAULT Logic HIGH State	TX_FAULT	-	V _{CC} +0.5	V		
Rx LOS Logic HIGH State	RX_LOS	-	V _{CC} +0.5	V		
MOD-DEF 2	MOD_DEF2	-	V _{CC} +0.5	V	Serial Data I/O	
MOD-DEF 1	I _{CLOCK}	100	-	kHz	Serial Clock	

Recommended Operating Conditions						
Parameter	Symbol	Min	Typ	Max	Units	Notes
Case Operating Temperature	T _{CASE}	0	25	+70	°C	
DC Supply Voltage	V _{CC}	3.14	-	5.25	Volts	
Module Supply Current	I _{CCR} + I _{CCT}	-	-	300	mA	3.3 V operation
Module Supply Current	I _{CCR} + I _{CCT}	-	-	300	mA	5.0 V operation

RECEIVER (1250 MB/s, 2⁷-1 PRBS)

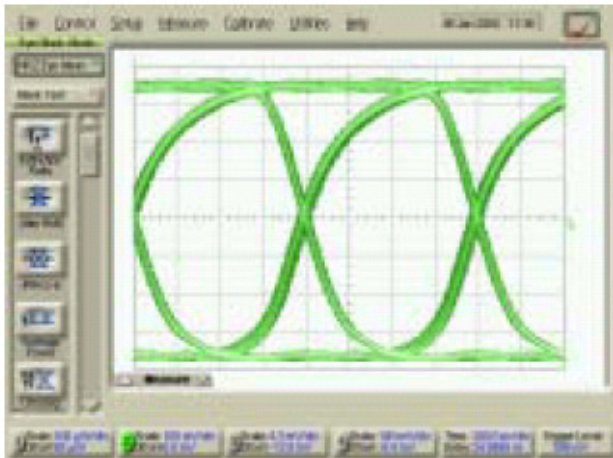

TRANSMITTER (1250 MB/s, 2⁷-1 PRBS)

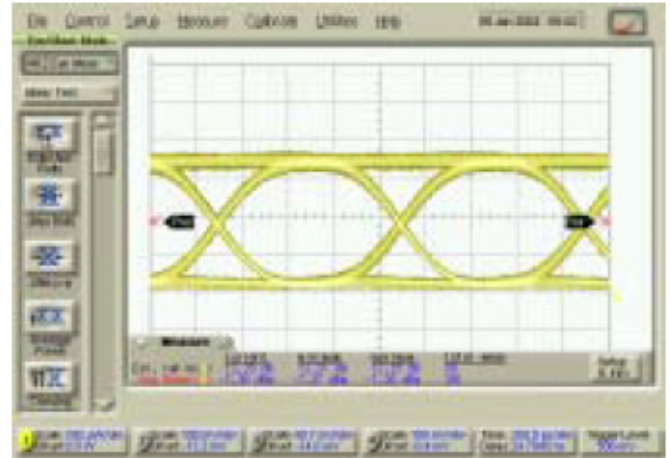



Transmitter Electro-Optical Characteristics (Tamb = 0 to 70°C)						
Parameter	Symbol	LTG1832			Units	Notes
		Min	Typ	Max		
Laser Type		CWDM DFB				
Optical Output Power	P _o	-1		+4	dBm	Average Optical Output
Optical Output Power	P _o	-	-	-35	dBm	Tx DISABLE Asserted
Extinction Ratio	ER	10	-	-	dB	
Center Wavelength	λ	1467	1470	1473	nm	LTG1832-47
		1487	1490	1493		LTG1832-49
		1507	1510	1513		LTG1832-51
		1527	1530	1533		LTG1832-53
		1547	1550	1553		LTG1832-55
		1567	1570	1573		LTG1832-57
		1587	1590	1593		LTG1832-59
		1607	1610	1613		LTG1832-61
Center Wavelength Temperature Drift Coefficient	λ _{DRIFT}	0.08	0.10	0.12	nm/°C	
Spectral Line Width@-20dB	Δλ	-	-	1	nm	
Side Mode Suppression Ratio	SMSR	30	-	-	dB	
Optical rise / fall time	tr / tf	-	-	260	ps	
Relative intensity noise	RIN	-	-	120	dB/Hz	
Total Jitter	J _T	-	-	227	ps	
Output Eye		IEEE 802.3z				
Tx DATA Differential Input Voltage (peak to peak)	V _{IN}	300	-	1600	mV pk-pk	150 Ohms / PECL

Transmitter Logic							
Monitor or Control Function	Condition	Logic State	Logic Type	Min	Max	Units	Notes
Tx FAULT	FAULT Condition	HIGH	TTL	2.4	V _{CC}	V	Tx is OFF
Tx FAULT	NORMAL Operation	LOW	TTL	0	0.5	V	Tx is ON
Tx DISABLE	Tx is DISABLED	HIGH	TTL	2.4	V _{CC}	V	Tx is OFF
Tx DISABLE	Tx is ENABLED	LOW	TTL	0	0.5	V	Tx is ON



Ligent

intelligent photonics

LTG1832 CWDM GBIC Optical Transceivers

1.25 Gb/s 1470 nm to 1610 nm 120 km

Receiver Electro-Optical Characteristics (Tamb = 0 to 70°C)						
Parameter	Symbol	LTG1832			Units	Notes
		Min	Typ	Max		
Receiver Type		APD / TIA				
Receiver Optical Sensitivity	P _{IN}	-33	-31	-	dBm	BER = 10 ⁻¹²
Maximum Receiver Optical Input	P _{IN MAX}	-	-	0	dBm	BER = 10 ⁻¹²
Center Wavelength	λ	1100	-	1650	nm	
Optical Return Loss	RL	12	-	-	dB	
Electrical Upper 3 dB Cutoff	f _c	-	-	1500	MHz	
Rx DATA Rise / Fall Time	t _r / t _f	-	-	350	ps	
Signal Loss - Assert	P _A	-	-	-36	dBm	
Signal Loss - Deassert	P _D	-39	-	-	dBm	
Signal Loss - Hysteresis	(P _A - P _D)	0.5	3	3	dB	

Receiver Logic						
Parameter	Function	Logic State	Logic Type	Min	Max	Units
RX_LOS	LOSS OF SIGNAL	HIGH	TTL	2.4	V _{CC}	V
RX_LOS	NORMAL	LOW	TTL	0	0.5	V
I ² C Serial ID Logic						
Parameter	Function	Logic State	Logic Type	Min	Max	Units
MOD_DEF 0	Digital Ground	Ground	N/A	0	0	V
MOD_DEF 1	Clock Signal	HIGH	TTL	2.4	V _{CC}	V
		LOW	TTL	0	0.5	V
MOD_DEF 2	Serial Data	HIGH	TTL	2.4	V _{CC}	V
		LOW	TTL	0	0.5	V



GBIC Pin Assignment

Pin	Symbol	Logic Type	Description
1	Rx LOSS of SIGNAL	LVTTL	Receiver Loss of Signal, HIGH = No Light, LOW = Normal Operation
2	V _{EER}	N/A	Receiver Ground
3	V _{EER}	N/A	Receiver Ground
4	MOD_DEF 0	LVTTL	Module Definition 0 - Two-Wire Interface Digital Ground
5	MOD_DEF 1	LVTTL	Module Definition 1 - Two-Wire Interface - Clock Signal
6	MOD_DEF 2	LVTTL	Module Definition 2 - Two-Wire Interface - Serial Data
7	Tx DISABLE	LVTTL	Transmitter Disable, HIGH = Transmitter OFF, LOW = Transmitter ON
8	V _{EET}	N/A	Transmitter Ground
9	V _{EET}	N/A	Transmitter Ground
10	Tx FAULT	LVTTL	Transmitter Fault, HIGH = Laser Fault, LOW = Normal Operation
11	V _{EER}	N/A	Receiver Ground
12	Rx DATA (-)	LVPECL	RX_Data Output (Inverted)
13	Rx DATA (+)	LVPECL	RX_Data Output (Non Inverted)
14	V _{EER}	N/A	Receiver Ground
15	V _{CCR}	N/A	Receiver DC Power
16	V _{CCT}	N/A	Transmitter DC Power
17	V _{EET}	N/A	Transmitter Ground
18	Tx DATA (+)	LVPECL	TX_Data Input (Non Inverted)
19	Tx DATA (-)	LVPECL	TX_Data Input (Inverted)
20	V _{EET}	N/A	Transmitter Ground

Notes

- Rx LOS requires an external 10K pull-up resistor
- Tx FAULT requires an external 10K pull-up resistor
- Tx DISABLE is internally connected to a 10K pull-up resistor
- MOD-DEF 0 requires an external 10K pull-up resistor
- MOD-DEF 1 requires an external 10K pull-up resistor
- MOD-DEF 2 requires an external 10K pull-up resistor
- Tx DATA is internally AC-Coupled and is differentially terminated
- Rx DATA is internally AC-Coupled and each DATA line is individually terminated to GROUND

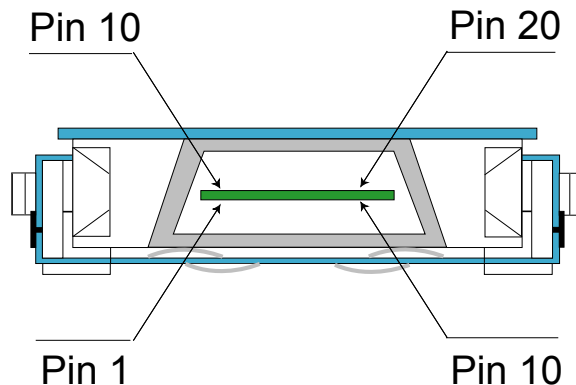

TRANSCEIVER BLOCK DIAGRAM

Transmitter Section PECL

The transmitter section consists of a high reliability DFB laser diode (LD) of a wavelength between 1470 to 1610 nm with back facet monitor photo detector (PD) in an eye safe optical sub-assembly (TOSA), which is mated to the Tx port of the fiber optic SC duplex receptacle. A driver IC converts differential input data signals into an analog current source that drives the LD. The transmitter is provided with the Tx_Disable and Tx_FAULT control and monitoring functions.

Receiver Section PECL

The receiver section consists of a high-speed InGaAs APD photodiode and a transimpedance preamplifier mounted in an optical sub-assembly (ROSA), which is mated to the Rx port of the fiber optic LC duplex receptacle. The output of the PD drives the post-amplification, quantizing, and optical signal detection circuits. The receiver is equipped with the Rx_LOS (Loss of Signal) monitoring function.

Digital Diagnostic Monitor TTL

The GBIC transceiver complies with Module Definition 4 of the GBIC MSA SFF-8053 dated 27 September 2000 relating to the incorporated EEPROM, which contains detailed product information stored for retrieval by the host equipment. The memory can be accessed via the 2-wire serial interface defined by the ATMEL AT24C01A protocol, which is organized as a series of 8-bit data words that can be addressed individually or sequentially.

Tx FAULT TTL

The Tx_FAULT (Transmit Fault) is an open collector monitor port. It switches states based on the condition of the laser driver and the laser including the end of life condition of the laser. If the parameters of the laser driver and laser are within specifications then the Tx_FAULT is set LOW indicating normal transceiver operation. If a fault occurs, including excess optical output power then Tx_FAULT is set HIGH which disables the transmitter. The Tx_FAULT can be reset to normal operation by toggling Tx_DIS or switching the power supply. The Tx_FAULT pin requires an external 4.7K to 10K Ohm pull-up resistor.

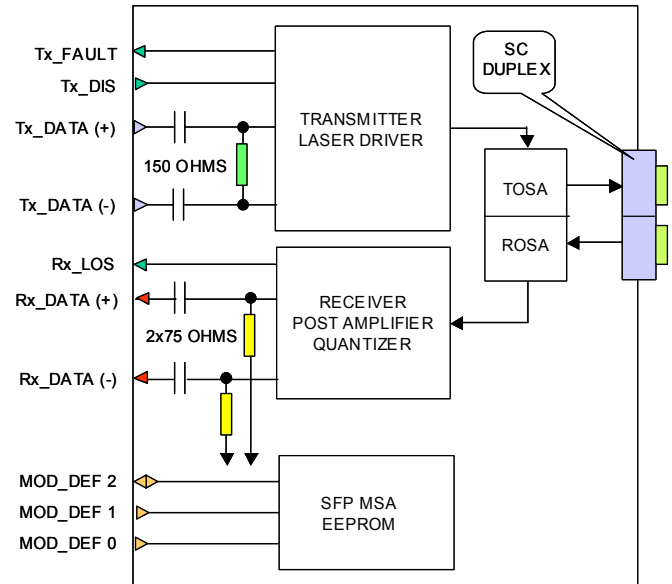

Tx DISABLE TTL

The Tx_DIS (Transmit Disable) is a control port that is controlled by a logic signal on the host / system printed circuit board. If the system is ready to send data then the Tx_DIS line is set LOW to enable the laser driver and the laser transmitter. If the system is not ready to send data then the Tx_DIS line is set HIGH to disable the transmitter. The laser will turn on within 1ms when TX_DIS is toggled LOW.

Rx_LOS TTL

The Rx_LOS (Loss of Signal) is an open collector output monitor port. It switches state based on the received optical input signal level that passes through the photo detector (PD), post amplifier and quantizer. If the received signal is above the Rx threshold, then Rx_LOS is set LOW indicating normal operation. If the received signal is below the Rx threshold, then Rx_LOS is set HIGH indicating a possible broken fiber, unplugged connector or low Tx signal from the host. The Rx_LOS pin requires an external 4.7K to 10K Ohm pull-up resistor.



GBIC TO HOST ELECTRICAL INTERFACE

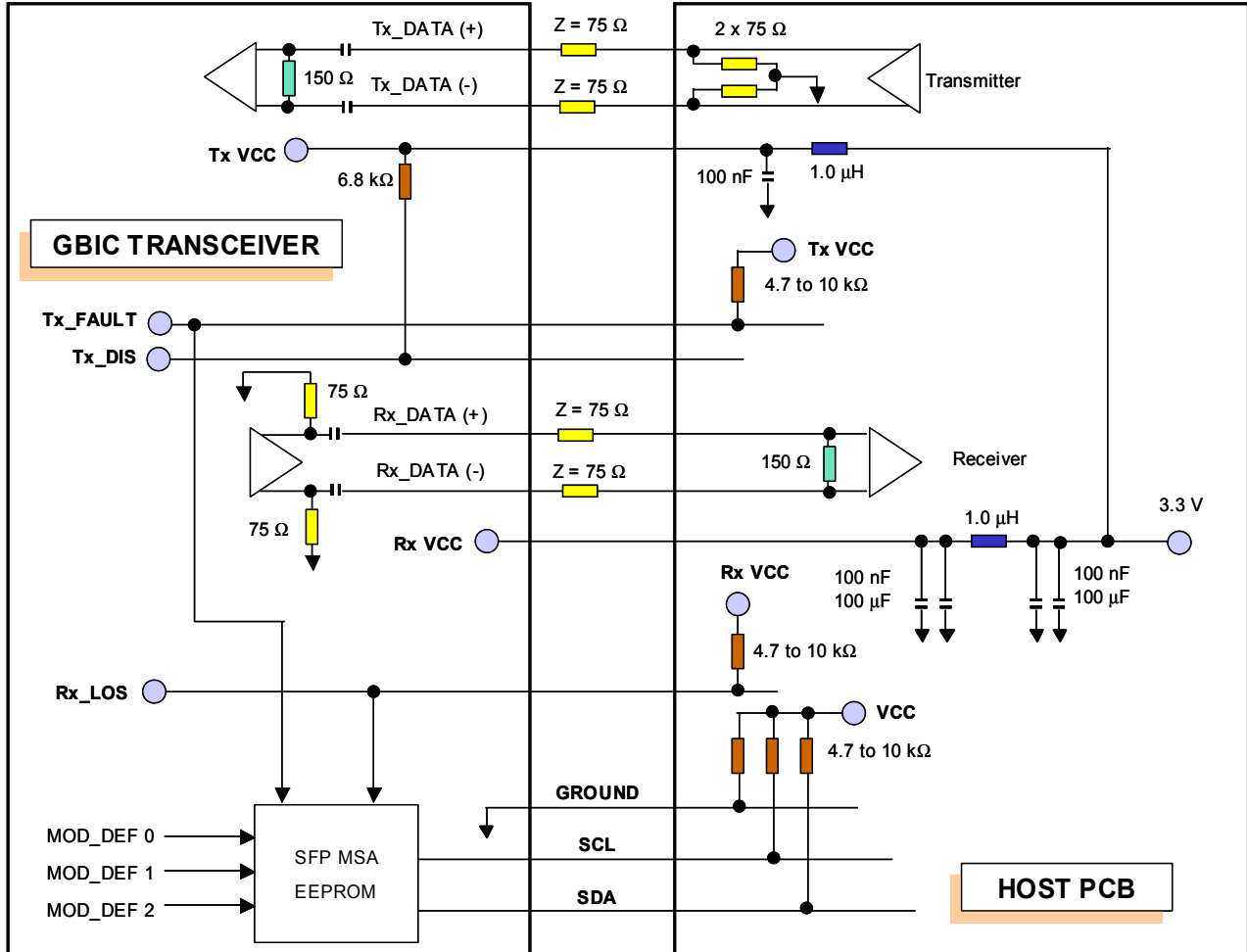



SFP MSA and SFF 8472 REVISION 9.3 DIGITAL DIAGNOSTICS

This device incorporates the SFF-8053 Revision 5.5 digital diagnostic monitoring and control functions for GBIC transceivers.

The data table at address A0 (HEX) contains 128-bytes of information relating to the type of device as shown in the table below. The data is programmed into memory at the time the device is manufactured and is normally WRITE PROTECTED.

The digital diagnostic interface enables the system host to discover the transceiver's parametric and data functions via a 2-wire system with one wire providing the clock and timing information and the other wire providing two-way communications with the transceiver. Additional information can be found in the SFF-8053 Rev 5.5 documentation.

Code Table for 8472 Digital Diagnostics - Page A0 HEX

Address	Bytes	HEX	DECIMAL	Name of Field	Field Description
00	1	01	1	ID Field	GBIC transceiver
01	1	06	6	Extended ID Field	GBIC is compliant with MOD-DEF 6 (GbE and F/C)
02	1	01	1	Connector ID Field	Fibre Channel definition of SC connector
06	1	02	2	Transceiver ID Field	1000BASE-LH
11	1	00	0	Transceiver Encoding	Unspecified
12	1	0D	13	Nominal Bit Rate	1250 Mb/s
14	1	28	40	Link Length	120 km
15	1	FF	255	Link Length > 25.4 km	GBIC compatibility requirement
20 to 35	16	XX	XX	Vendor Name	Ligent Photonics
37 to 39	3	XX	XX	Vendor IEEE ID	TBD - assigned at time of production
40 to 55	16	XX	XX	Ligent Part Number	LTG1832-XX - assigned at time of production
56 to 59	4	XX	XX	Ligent Rev Number	0 - assigned at time of production
60 to 61	2	XX	XX	Wavelength	See Wavelength Table Page 8
65	1	1A	26	GBIC Codes	Rx LOS, Tx DIS, Tx FAULT
66, 67	1	XX	XX	Bit Rate Max Tolerance	20 percent - assigned at time of production
68 to 83	16	XX	XX	Ligent Serial Number	Assigned at time of production
84 to 91	8	XX	XX	Ligent Date Code	Assigned at time of production

Address 60 and 61 - Wavelength Description (1470 to 1610 nm)

Ligent Part Number	Wavelength 25°C	Address 60 HEX (MSB)	Address 61 HEX (LSB)	16-BIT HEX Value (MSB+LSB)	DECIMAL Equivalent
LTG1832-47	1470 nm	05	BE	05BE	1470
LTG1832-49	1490 nm	01	EA	01EA	1490
LTG1832-51	1510 nm	05	E6	05E6	1510
LTG1832-53	1530 nm	05	FA	05FA	1530
LTG1832-55	1550 nm	06	0E	060E	1550
LTG1832-57	1570 nm	06	22	0622	1570
LTG1832-59	1590 nm	06	36	0636	1590
LTG1832-61	1610 nm	06	4A	064A	1510



Ligent

intelligent photonics

LTG1832 CWDM GBIC Optical Transceivers

1.25 Gb/s 1470 nm to 1610 nm 120 km

GBIC PACKAGE OUTLINE DRAWING

Dimensions are in mm

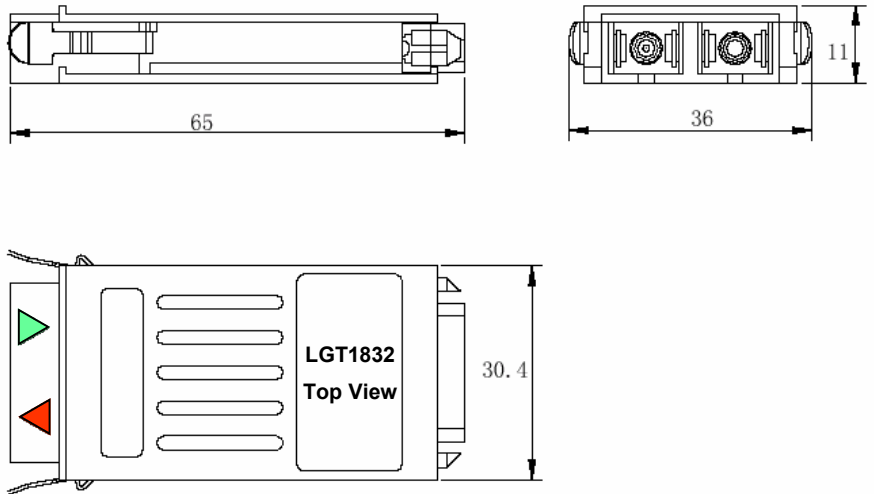

Laser Emission

Indication of laser aperture and beam

REGULATORY INFORMATION

Eye Safety

The transceiver is a Class 1 eye-safe device according to FDA 21CFR1040.10 and IEC 60825-1. Do not attempt to look directly at the laser beam with naked eye or through optical equipment without suitable laser eye-safety glasses. Failure to observe this warning will result in permanent eye damage.

Electromagnetic Interference (EMI), Immunity and Product Safety

The transceiver is ESD safe (electrical pins) when tested according to MIL-STD-883, Method 3015.7 and ESD safe (optical connector) when tested according to IEC 61000-4-2. The device is immune to strong RF fields when tested in accordance with IEC 61000-4-3. The device complies with (US) FCC, Part 15; (Europe) CENELEC EN 55022;

(Canada) Class B (CISPR22A); and (Japan) VCCI Class 1. The device has been designed to conform to product safety requirements including UL1950, CSA 22.2, and IEC 60950-1, and has been designed to meet the flammability requirements of UL94.

Notice

The factory has made all adjustments to this device prior to shipment. No adjustments or modifications to the device are required or permitted. Any adjustment, modification or tampering of the device voids the product warranty. The US Food and Drug Administration may consider that any adjustment or modification to this device is an act of manufacturing and therefore will require that the device be recertified in accordance with 21 CFR 1040.10.

Required Label

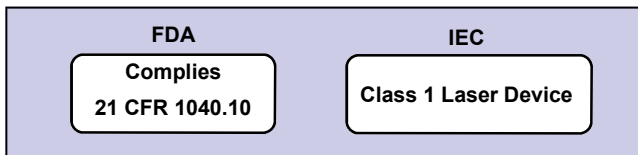

Laser Radiation Information

Wavelength	1550 nm
FDA Total Pout: 7 mm aperture at 20 cm distance	< 195 microwatts
IEC Total Pout : 7 mm aperture at 14 cm distance	< 2000 microwatts
Beam Divergence	6°



Ligent

intelligent photonics

LTG1832 CWDM GBIC Optical Transceivers

1.25 Gb/s 1470 nm to 1610 nm 120 km

LIGENT SALES OFFICES

Ligent Photonics

2701 Dukane Drive
Suite 200
St. Charles, IL 60174
PH (630) 513-7226
FX (630) 513-9173
WS www.ligentphotonics.com

New Age Electronics

8376 Six Forks Road
Suite 202
Raleigh, NC 27615
PH (919) 866-0620
FX (919) 866-0621
WS www.newagelec.com

KJS Marketing

7872 Olive Lane North
Maple Grove, MN 55311
PH (763) 391-6557
FX (763) 391-6554
WS www.kjsmarketing.com

Kruvand Associates

1202 Richardson Drive
Suite 113
Richardson, TX 75080
PH (972) 437-3355
FX (972) 680-8854
WS www.kruvand.com

Ligent Photonics

(Virginia Sales Office)
8210 Strathmore Lane
Roanoke, VA 24019
PH (540) 797-5793
FX (540) 366-5793
WS www.ligentphotonics.com

New Age Electronics

4900 Corporate Drive
Suite B
Huntsville, AL 35805
PH (256) 430-8000
FX (256) 430-8414
WS www.newagelec.com

KJS Marketing

2A Street
Lake Lotawana, MO 64086
PH (816) 578-4751
FX (816) 774-2571
WS www.kjsmarketing.com

Kruvand Associates

8100 Shoal Creek Boulevard
Suite 250
Austin, TX 75080
PH (512) 454-1111
FX (512) 454-9858
WS www.kruvand.com

Bitel Technologies LTD

Nur Building
43 Ha'Atzmaut Way
PO BOX 94
Yehud, 56302, Israel
PH +(972) 3-6322655
FX +(972) 3-6322279
WS www.bitel.co.il

New Age Electronics

182 Sunset Drive
Mt. Dora, FL 32757
PH: (352) 735-6101
FX: (352) 735-6116
WS: www.newagelec.com

KJS Marketing

1802 Hammer Drive, NW
Cedar Rapids, IA 52405
PH (319) 265-8592
FX (319) 265-8593
WS www.kjsmarketing.com

Kruvand Associates

10601 Grant Road
Suite 104
Houston, TX 77070
PH (713) 956-6741
FX (713) 972-680-8854
WS www.kruvand.com

New Age Electronics

3000 Northwood's Parkway
Suite 280
Norcross, GA 30071
PH (770) 242-8800
FX (770) 242-8180
WS www.newagelec.com

New Age Electronics

100 SE 5th Court
Suite 37
Pompano Beach, FL 33060
PH: (407) 804-1210
FX: (954) 928-2889
WS: www.newagelec.com

KJS Marketing

PO Box 1521
Maryland Heights, MO 63043
PH (314) 469-4544
FX (314) 469-4535
WS www.kjsmarketing.com

K-Tech Sales

100 Century Center Court
Suite 405
San Jose, CA 95112
PH (408) 437-1808
FX (408) 437-1883
WS www.ktechsales.com

KJS Marketing

PO Box 72
Crystal Lake, IL 60039
PH (815) 788-1002
FX (815) 788-1004
WS www.kjsmarketing.com

KJS Marketing

154 Struckman Blvd
Bartlett, IL 60103
PH (630) 289-4548
FX (630) 289-3778
WS www.kjsmarketing.com

Starvoy Technologies

4017 Carling Avenue
Suite 301
Kanata, Ontario K2K-2A3
PH (613) 592-8910
FX (613) 592-5441
WS www.starvoy.com