



Ligent

intelligent photonics

LTD1730-WL CWDM SFP Optical Transceivers

Gigabit Ethernet 1270 to 1610 nm 1250 Mb/s 80 km

Product Description

The LTD1730-WL CWDM SFP GBE LC duplex transceiver product family is intended for 80 km reach service in 1.25 Gb/s 1270 to 1610 nm single mode high-speed data communications equipment where low-cost, extraordinary performance and reliability are essential. They meet the requirements of IEEE 802.3z 1000BASE-LH, consume low power, operate from a 3.3 volt DC power supply and are offered in the 0 to 70°C commercial temperature range. The industry standard 2x10 small form pluggable (SFP) package is fabricated with a rugged die cast metal housing and cage assembly. The low jitter and low bit error rate optical assemblies features a DFB laser transmitter and PIN/TIA receiver. They incorporate the SFP MSA LVTTTL Loss of Signal (Rx_LOS), Tx Fault (Tx_FAULT) and Tx Disable (Tx_DIS) monitor and control functions and the SFP MSA compliant digital diagnostic monitor feature which is accessed via the I²C 2-wire serial ID interface. The differential AC coupled Tx and Rx data interfaces (50 ohms to ground, 100 ohms line to line) are LVPECL compatible. The devices are Class I laser safety compliant.



Applications

- 1250 Mb/s GBE equipment
- Rack to rack system interconnects
- Metro / Access Networks
- Switch to switch interfaces
- Hub interconnects
- Bus extenders
- Channel extenders
- Host adapter interconnects
- Mass storage system interconnects
- Telecom switches
- Router interconnects

Features

- LC Duplex optical interface
- 80 km reach
- 1250 Mb/s data rate
- +3.3 V power supply
- Low DC power consumption
- 2x10 SFP MSA compliant package
- Bail or pull latch option
- Hot swappable
- High performance 1270 to 1610 nm DFB laser
- High sensitivity PIN/TIA optical receiver
- Single Mode operation
- BER < 1X10⁻¹² (2⁷ - 1 NRZ PRBS test pattern)
- IEEE 802.3z 1000BASE-LH compliant
- 0 to 70°C Operating temperature range:
- Loss of Signal (Rx_LOS), LVTTTL
- Tx Disable (Tx_DIS), LVTTTL
- Tx Fault (Tx_FAULT), LVTTTL
- 2-wire I²C data bus
- SFP MSA compliant diagnostics
- Internally AC coupled and terminated
- LVPECL Rx and Tx data interface
- 100 Ohms differential (line to line)
- 50 Ohms single ended (line to ground)

Ordering Information	
Latch Options	Bail and Pull Latches are compatible with the dimensions defined by the SFP MSA
Ambient Operating Temperature	Commercial

Part Number	Wavelength	Part Number	Wavelength
LTD1730-27 XYZ	1270 nm	LTD1730-47 XYZ	1470 nm
LTD1730-29 XYZ	1290 nm	LTD1730-49 XYZ	1490 nm
LTD1730-31 XYZ	1310 nm	LTD1730-51 XYZ	1510 nm
LTD1730-33 XYZ	1330 nm	LTD1730-53 XYZ	1530 nm
LTD1730-35 XYZ	1350 nm	LTD1730-55 XYZ	1550 nm
LTD1730-37 XYZ	1370 nm	LTD1730-57 XYZ	1570 nm
LTD1730-39 XYZ	1390 nm	LTD1730-59 XYZ	1590 nm
LTD1730-41 XYZ	1410 nm	LTD1730-61 XYZ	1610 nm
LTD1730-43 XYZ	1430 nm		
LTD1730-45 XYZ	1450 nm		

Schedule of LTD1730-WL XYZ Ordering Options			
Option	X	Y	Z
Bail Latch Option	B		
Pull Latch Option	P		
Commercial Temperature Range		C	
Non-RoHS Compliant Option			Blank
RoHS Complaint Option			R



Ligent

intelligent photonics

LTD1730-WL CWDM SFP Optical Transceivers

Gigabit Ethernet 1270 to 1610 nm 1250 Mb/s 80 km

Absolute Maximum Ratings (EXCEEDING THESE RATINGS MAY CAUSE IRREVERSIBLE DAMAGE TO THE DEVICE)

Parameter	Symbol	Minimum	Maximum	Units
Storage Temperature	T _{stg}	-40	+85	°C
Relative Humidity - Storage	RH _S	0	95	%
Relative Humidity - Operating	RH _O	0	85	%
DC Supply Voltage	V _{CC}	0	3.6	V
Soldering Temperature	T _{slid}	0	260	°C
Soldering Time Duration	t _{slid}	0	10	seconds
Tx DATA	V _{in}	0	V _{CC} + 0.5	V

Optical and Electrical Signal Absolute Maximum Ratings

Signal / Data Input Voltage (Tx_DATA)	V _{IN PK-PK}	-	2.4	V
SFP Clock Signal (Standard Mode)	I _{CLOCK}	100	-	kHz
SFP Clock Signal (Fast Mode)	I _{CLOCK}	-	400	kHz
Rx Optical Input Power	P _{IN-MAX}	-	3	dBm

Logic State Absolute Maximum Ratings

Tx_DISABLE Logic HIGH State	Tx_DIS	-	V _{CC} +0.5	V
Tx_FAULT Logic HIGH State	Tx_FAULT	-	V _{CC} +0.5	V
Rx_LOS Logic HIGH State	Rx_LOS	-	V _{CC} +0.5	V
SFP MOD-DEF2	MOD_DEF2	-	V _{CC} +0.5	V

Recommended Operating Conditions

Parameter	Symbol	Min	Typ	Max	Units	Notes
Ambient Operating Temperature	T _{amb}	0	25	+70	°C	Temperature Range = C
DC Supply Voltage	V _{CC}	3.14	3.30	3.46	Volts	
Module Supply Current	I _{IN}	-	180	250	mA	
Power Dissipation	P _D	-	600	875	mW	



Ligent

intelligent photonics

LTD1730-WL CWDM SFP Optical Transceivers

Gigabit Ethernet 1270 to 1610 nm 1250 Mb/s 80 km

Transmitter Logic						
Parameter	Function	Logic State	Logic Type	Min	Max	Units
Tx_DIS and Tx_FAULT	DISABLE	HIGH	LVTTL	2.4	V _{CC} +0.3	V
Tx_DIS and Tx_FAULT	ENABLE	LOW	LVTTL	0	0.8	V
Tx_DIS	Assert Time	-	LVTTL	-	10	μs
Receiver Logic						
Parameter	Function	Logic State	Logic Type	Min	Max	Units
Rx_LOS	LOSS OF SIGNAL	HIGH	LVTTL	2.4	V _{CC} +0.3	V
Rx_LOS	NORMAL	LOW	LVTTL	0	0.8	V
I ² C Serial ID Logic						
Parameter	Function	Logic State	Logic Type	Min	Max	Units
MOD_DEF 0	Digital Ground	Ground	N/A	0	0	V
MOD_DEF 1	Clock Signal	HIGH	LVTTL	2.4	V _{CC} +0.3	V
		LOW	LVTTL	0	0.8	V
MOD_DEF 2	Serial Data	HIGH	LVTTL	2.4	V _{CC} +0.3	V
		LOW	LVTTL	0	0.8	V

Transmitter Electro-Optical Characteristics						
Parameter	Symbol	LTD1730-WL			Units	Notes
		Min	Typ	Max		
Laser Type		DFB				
Optical Output Power	P _o	0	+1	+3	dBm	Average Optical Output
Center Wavelength	λ		1270-1610 nm		nm	
Center Wavelength Deviation at 25°C	λ ₀	-3	-	+3	nm	
Center Wavelength Temperature Drift Coefficient	λ _{DRIFT}	`	0.1	`	nm/°C	
Spectral Line Width@-20dB	Δλ	-	-	1	nm	
Extinction Ratio	ER	9	10	-	dB	
Side Mode Suppression Ratio	SMSR	30	-	-	dB	
Optical Rise and Fall Time	t _r , t _f	-	-	260	ps	20% - 80%
Relative Intensity Noise	RIN	-	-	-120	dB/Hz	
Transmitter Generated RMS Jitter	J _{RMS}	-	-	0.01	UI	
Output Eye		IEEE 802.3z 1000BASE-LH				
Tx Differential Input Impedance	Z _{in}	-	100	-	Ohms	
Tx Differential Input Voltage	V _{IN}	400	-	2400	mV p-p	LVPECL Tx DATA (Note 1)

Note 1: Internally AC coupled and terminated



Receiver Electro-Optical Characteristics

Parameter	Symbol	LTD1730-WL			Units	Notes
		Min	Typ	Max		
Receiver Type		PIN / TIA				
Receiver Optical Sensitivity	P_{IN}	-	-	-24	dBm	Average Received Power (Note 1)
Receiver Optical Overload	$P_{IN MAX}$	-	-	0	dBm	
Center Wavelength	λ	1260	1550	1660	nm	
Optical Return Loss	RL	27	-	-	dB	
Rx Upper 3 dB Cutoff Frequency	f_c	-	-	1500	MHz	
Signal Loss - Assert	P_{SLA}	-37	-	-24	dBm	
Signal Loss - Deassert	P_{SLD}	-37.5	-	-24.5	dBm	
Signal Loss - Hysteresis	P_H	0.5	2	5	dB	
Data Output Rise / Fall Time	t_r / t_f		300	-	ps	20 - 80 %
Rx Differential Load Impedance	Z_{LOAD}	-	100	-	Ohms	
Rx Differential Output Voltage	V_{OUT}	400	-	1400	mV p-p	LVPECL Rx DATA (Note 2)

Note 1: Average received power where the BER = 10^{-12} , measured with a 2^7-1 NRZ test pattern

Note 2: Internally AC coupled and terminated

Eye Diagram

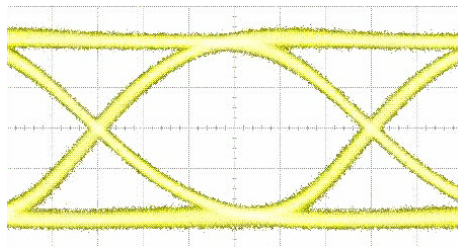

Transmitter Test Conditions

- Optical Output Power = 0 dBm
- Test Pattern = 2^7-1 NRZ PRBS

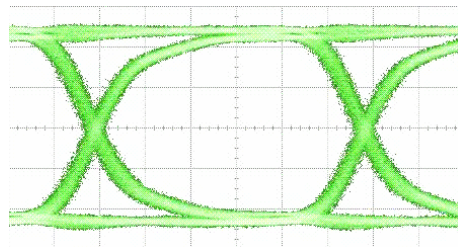

Receiver Test Conditions

- Optical Input Power = -17 dBm
- Test Pattern = 2^7-1 NRZ PRBS



Transceiver Block Diagram

Transmitter Section

The transmitter section consists of a high reliability DFB laser diode (LD) (wavelength between 1270 and 1610 nm) with back facet monitor photo detector (PD) in an eye safe optical sub-assembly (TOSA), which is mated to the Tx port of the fiber optic LC duplex receptacle. A driver IC converts LVPECL differential input data signals into an analog current source that drives the LD. The transmitter is provided with the Tx_Disable and Tx_FAULT control and monitoring functions. SFP MSA digital diagnostics are enabled via the 2-wire I²C data bus.

Receiver Section

The receiver section consists of a high-speed InGaAs PIN photodiode of (wavelength between 1270 and 1610 nm) and a transimpedance preamplifier mounted in an optical subassembly (ROSA), which is mated to the Rx port of the fiber optic LC duplex receptacle. The output of the PD drives the post-amplification, quantizing, and optical signal detection circuits. The receiver is equipped with the Rx_LOS (Loss of Signal) monitoring function.

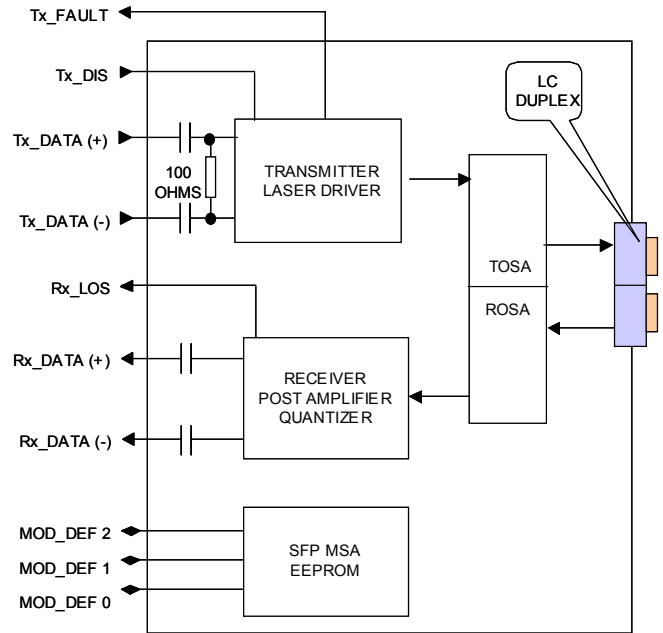

Transceiver Monitor and Control Functions

Rx Signal Loss (Rx_LOS) Description

The Rx_LOS (Loss of Signal) is an open collector LVTTTL monitor port. It switches state based on the received optical input signal level that passes through the photo detector (PD), post amplifier and quantizer. If the received signal is above the Rx threshold, then Rx_LOS is set LOW indicating normal operation. If the received signal is below the Rx threshold, then Rx_LOS is set HIGH indicating a possible broken fiber, unplugged connector or low Tx signal from the host. The Rx_LOS pin requires an external 4.7K to 10 K Ohm pull-up resistor.

Tx Disable (Tx_DIS) Description

The Tx_DIS (Transmit Disable) is an open collector LVTTTL control port that is controlled by a logic signal on the host (system) printed circuit board. If the system is ready to send data then the Tx_DIS line is set LOW to enable the laser driver and the laser transmitter. If the system is not ready to send data, then the Tx_DIS line is set HIGH to disable the transmitter.

Tx Fault (Tx_FAULT) Description

The Tx_FAULT (Transmit Fault) is an open collector LVTTTL monitor port. It switches states based on the condition of the laser driver and the laser including the end of life condition of the laser. If the parameters of the laser driver and laser are within specifications then the Tx_FAULT is set LOW indicating normal transceiver operation. If a fault occurs, including excess optical output power then Tx_FAULT is set HIGH which disables the transmitter. The Tx_FAULT can be reset to normal operation by toggling Tx_DIS or switching the power supply. The Tx_FAULT pin requires an external 4.7K to 10K Ohm pull-up resistor.



Ligent

intelligent photonics

LTD1730-WL CWDM SFP Optical Transceivers

Gigabit Ethernet 1270 to 1610 nm 1250 Mb/s 80 km

Electrical Interface

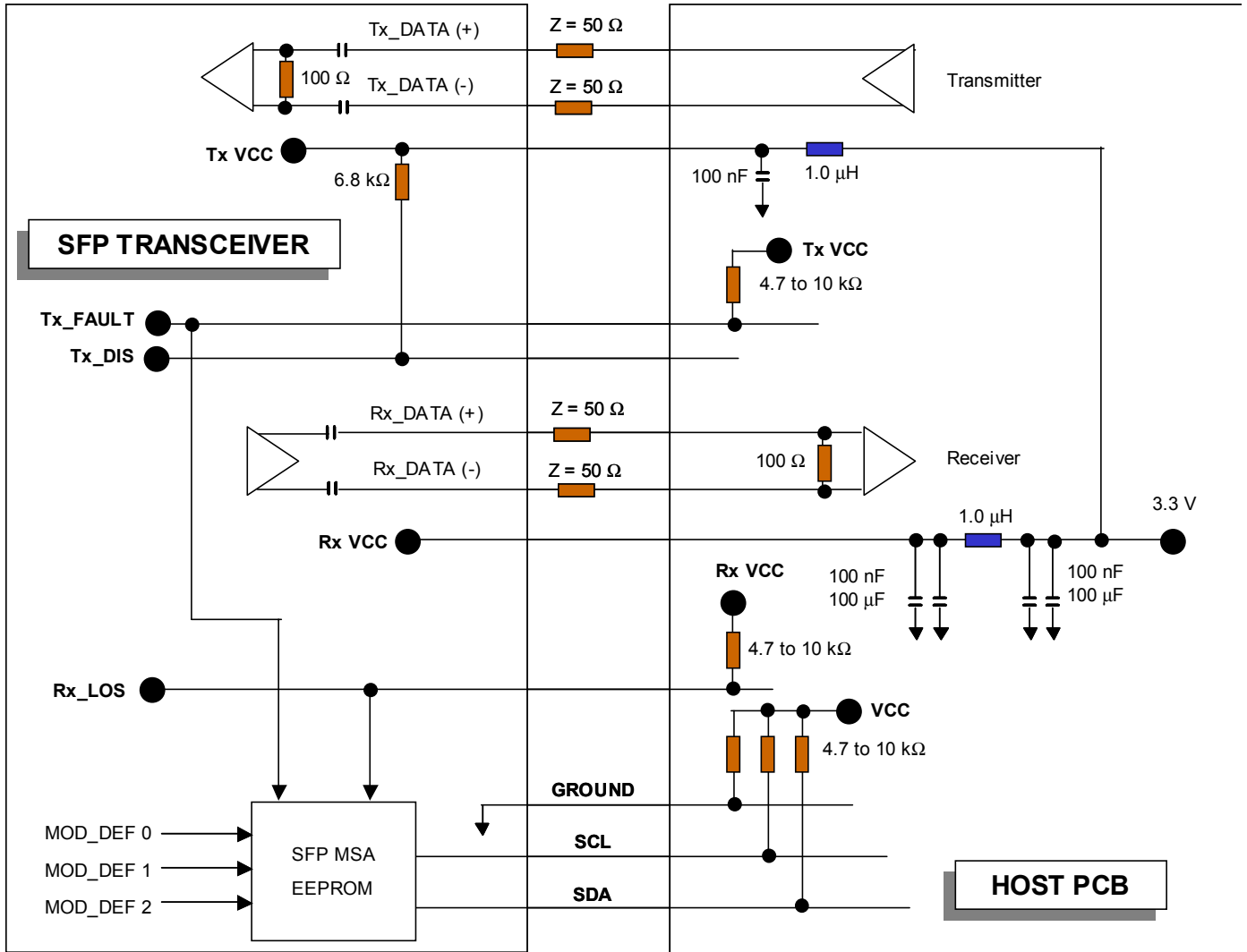



Ligent

intelligent photonics

LTD1730-WL CWDM SFP Optical Transceivers

Gigabit Ethernet 1270 to 1610 nm 1250 Mb/s 80 km

Pin Assignment

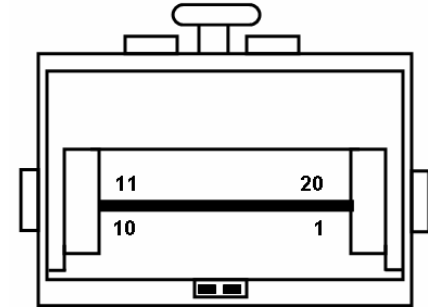
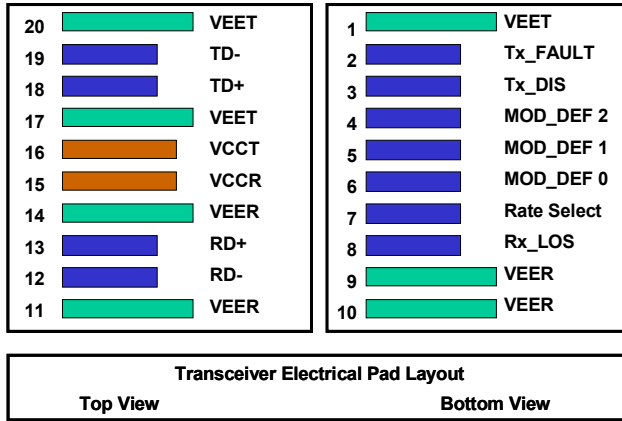

SFP Pin Assignment

Pin	Symbol	Logic Type	Description	Notes
1	VEET	N/A	Transmitter Ground	
2	Tx_FAULT	LVTTTL	Transmitter Fault, LOW = Normal Operation, HIGH = Fault Indication	Note 1
3	Tx_DIS	LVTTTL	Transmit Disable, LOW = Normal Operation, HIGH = Disables Module	Note 1
4	MOD_DEF 2	LVTTTL	Module Definition 2 - Two-Wire Interface - Serial Data	Note 1
5	MOD_DEF 1	LVTTTL	Module Definition 1 - Two-Wire Interface - Clock Signal	Note 1
6	MOD_DEF 0	LVTTTL	Module Definition 0 - Two-Wire Interface Digital Ground	
7	Rate Select	N/A	Not Connected	
8	Rx_LOS	LVTTTL	Receiver Loss of Signal, LOW = Normal Operation, HIGH = Loss of Signal	Note 1
9	VEER	N/A	Receiver Ground	
10	VEER	N/A	Receiver Ground	
11	VEER	N/A	Receiver Ground	
12	RD-	LVPECL	Rx_Data Output (Inverted)	Note 2
13	RD+	LCPECL	Rx_Data Output (Non Inverted)	Note 2
14	VEER	N/A	Receiver Ground	
15	VCCR	N/A	Receiver DC Power	3.3 V +/- 5%
16	VCCCT	N/A	Transmitter DC Power	3.3 V +/- 5%
17	VEET	N/A	Transmitter Ground	
18	TD+	LVPECL	Tx_Data Input (Non Inverted)	Note 3
19	TD-	LVPECL	Tx_Data Input (Inverted)	Note 3
20	VEET	N/A	Transmitter Ground	

Notes

1	The uncommitted Tx_Fault, Rx_LOS, MOD_DEF 1 and MOD_DEF 2 LVTTTL monitor and control pins each require a pull up resistor of 4.7K to 10K Ohms.
2	The 100 Ohm differential Rx Data output is internally AC coupled and must be terminated with 100 Ohms at the differential user interface.
3	The 100 Ohm differential Tx Data input is internally AC coupled and terminated.



Ligent

intelligent photonics

LTD1730-WL CWDM SFP Optical Transceivers

Gigabit Ethernet 1270 to 1610 nm 1250 Mb/s 80 km

Mechanical Dimensions

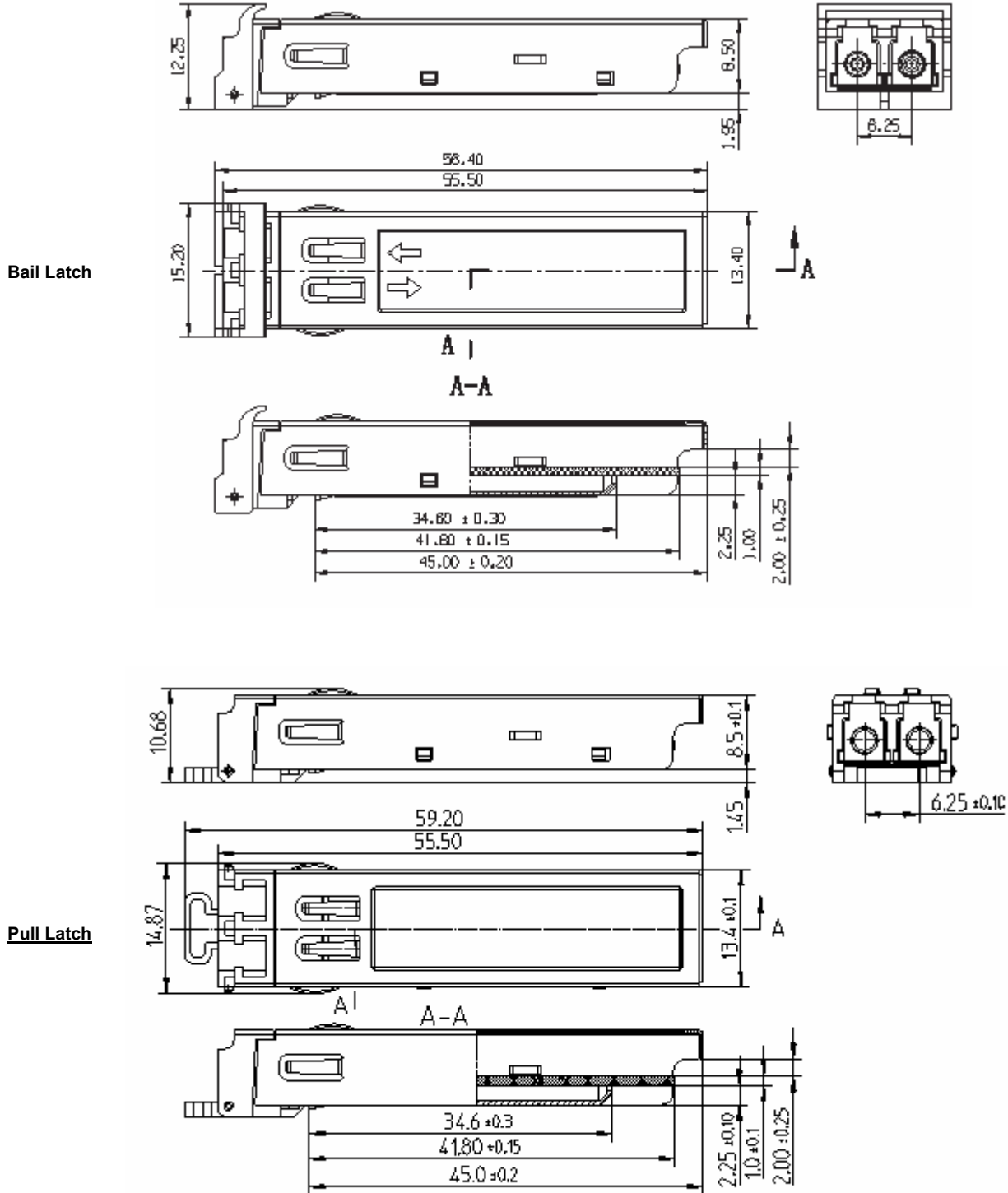

Dimensions are in millimeters
Dimension tolerance is ± 0.1mm unless otherwise specified



Regulatory Information

Eye Safety

The transceiver is a Class 1 eye-safe device according to FDA 21CFR1040.10 and IEC 60825-2.

Electromagnetic Interference (EMI), Immunity and Product Safety

The transceiver is ESD safe (electrical pins) when tested according to MIL-STD-883, Method 3015.7 and ESD safe (optical connector) when tested according to IEC 61000-4-2. The device is immune to strong RF fields when tested in accordance with IEC 610004-3. The device complies with (US) FCC, Part 15, Subpart J; (Europe) CENELEC EN 55022; (Canada) Class B (CISPR22A); and (Japan) VCCI Class 1. The device has been designed to conform to product safety requirements including UL1950, CSA 22.2, and IEC 60950-1, and has been designed to meet the flammability requirements of UL94.

Notice

The factory has made all adjustments to this device prior to shipment. No adjustments or modifications to the device are required or permitted. Any adjustment, modification or tampering of the device voids the product warranty. The US Food and Drug Administration may consider that any adjustment or modification to this device is an act of manufacturing and therefore will require that the device be recertified in accordance with 21 CFR 1040.10 Subpart j.

Laser Radiation Information	
Wavelength	1270 nm -1610 nm
FDA Total Pout: 7 mm aperture at 20 cm distance	< 195 microwatts
IEC Total Pout : 7 mm aperture at 14 cm distance	< 2000 microwatts
Beam Divergence	6°

Required Label

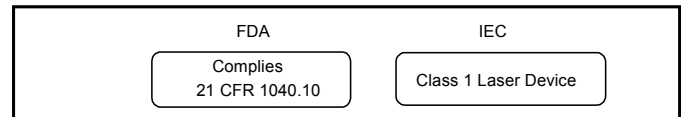

Laser Emission

