

### Product Description

The LTD1314 SFP Gigabit Ethernet LC duplex transceiver is intended for 40 km reach service in 1250 Mb/s 1310 nm single mode high-speed LAN and SAN data communications equipment where low-cost, extraordinary performance and reliability are essential. It meets the requirements of IEEE802.3z 1000 BASE-LX, consumes low power, operates from a 3.3 volt DC power supply and is offered in the commercial, extended and industrial temperature ranges. The industry standard 2x10 small form pluggable (SFP) package is fabricated with a rugged die cast metal housing and cage assembly. The low jitter and low bit error rate optical assembly features a 1310 nm DFB laser transmitter and PIN/TIA receiver. It incorporates the SFP MSA LVTTTL Loss of Signal (Rx\_LOS), Tx Fault (Tx\_FAULT) and Tx Disable (Tx\_DIS) monitor and control functions and the SFF-8472 Rev 9.3 compliant digital diagnostic monitor feature which is accessed via the I<sup>2</sup>C 2-wire serial ID interface (MOD\_DEF 0-1-2). The differential AC coupled Tx and Rx data interfaces (50 ohms to ground, 100 ohms line to line) are LVPECL compatible. The device is Class I laser safety compliant.



### Applications

- 1250 Mb/s Gigabit Ethernet data links
- Channel extenders
- Bus extenders
- High speed I/O file servers
- Data storage networks
- LAN
- SAN
- RSAN
- Host adapters
- Switch-to-switch interfaces
- Mass storage system interconnects
- Hub interconnects
- Router interconnects
- Distributed multi processing
- Telecom switches

### Features

- LC Duplex optical interface
- 40 km reach
- 1250 Mb/s data rate
- +3.3 V power supply
- Low DC power consumption
- 2x10 SFP MSA compliant package
- Bail or pull latch option
- Hot swappable
- High performance 1310 nm DFB laser
- High sensitivity PIN/TIA optical receiver:
- Single Mode operation
- BER < 1X10<sup>-12</sup> (2<sup>7</sup> - 1 NRZ PRBS test pattern)
- IEEE 802.3z 1000 BASE-LX compliant
- Operating temperature range options:
  - Commercial: 0 to 70°C
  - Extended: -10 to 80°C
  - Industrial: -40 to 85°C
- Monitor and Control Functions
  - Loss of Signal (Rx\_LOS), LVTTTL
  - Tx Disable (Tx\_DIS), LVTTTL
  - Tx Fault (Tx\_FAULT), LVTTTL
  - 2-wire I<sup>2</sup>C data bus
  - SFF-8472 Rev 9.3 MSA compliant
  - Internally AC coupled and terminated
  - LVPECL Rx and Tx data interface
    - 100 Ohms differential (line to line)
    - 50 Ohms single ended (line to ground)



**Absolute Maximum Ratings (EXCEEDING THESE RATINGS MAY CAUSE IRREVERSIBLE DAMAGE TO THE DEVICE)**

Parameter	Symbol	Minimum	Maximum	Units
Storage Temperature	T <sub>stg</sub>	-40	+85	°C
Relative Humidity - Storage	RH <sub>S</sub>	0	95	%
Relative Humidity - Operating	RH <sub>O</sub>	0	85	%
DC Supply Voltage	V <sub>CC</sub>	0	3.6	V
Soldering Temperature	T <sub>slid</sub>	0	260	°C
Soldering Time Duration	t <sub>slid</sub>	0	10	seconds
Tx DATA	V <sub>in</sub>	0	V <sub>CC</sub> + 0.5	V

**Optical and Electrical Signal Absolute Maximum Ratings**

Signal / Data Input Voltage (Tx_DATA )	V <sub>IN PK-PK</sub>	-	2.4	V
8472 Clock Signal (Standard Mode)	I <sub>CLOCK</sub>	100	-	kHz
8472 Clock Signal (Fast Mode)	I <sub>CLOCK</sub>	-	400	kHz
Rx Optical Input Power	P <sub>IN-MAX</sub>	-	3	dBm

**Logic State Absolute Maximum Ratings**

Tx_DISABLE Logic HIGH State	Tx_DIS	-	V <sub>CC</sub> +0.5	V
Tx_FAULT Logic HIGH State	Tx_FAULT	-	V <sub>CC</sub> +0.5	V
Rx_LOS Logic HIGH State	Rx_LOS	-	V <sub>CC</sub> +0.5	V
8472 MOD-DEF2	MOD_DEF2	-	V <sub>CC</sub> +0.5	V

**Recommended Operating Conditions**

Parameter	Symbol	Min	Typ	Max	Units	Notes
Ambient Operating Temperature	T <sub>amb</sub>	0	25	+70	°C	Temperature Range = C
		-10	25	+80	°C	Temperature Range = E
		-40	25	+85	°C	Temperature Range = H
DC Supply Voltage	V <sub>CC</sub>	3.14	3.30	3.46	Volts	
Module Supply Current	I <sub>IN</sub>	-	150	200	mA	
Power Dissipation	P <sub>D</sub>	-	500	700	mW	

**Ordering Information**

Latch Options	Bail and Pull Latches are compatible with the dimensions defined by the SFP MSA
Ambient Operating Temperature	Commercial, Extended or Industrial

Part Number	Latch Option (X)		Temperature Option (Y)	
<b>LTD1314 XY</b>	B	Bail	C	0 to 70 °C
	P	Pull	E	-10 to 80 °C
			H	-40 to 85 °C



Transmitter Logic						
Parameter	Function	Logic State	Logic Type	Min	Max	Units
Tx_DIS and Tx_FAULT	DISABLE	HIGH	LVTTL	2.4	V <sub>CC</sub> +0.3	V
Tx_DIS and Tx_FAULT	ENABLE	LOW	LVTTL	0	0.8	V
Tx_DIS	Assert Time	-	LVTTL	-	10	µs

Receiver Logic						
Parameter	Function	Logic State	Logic Type	Min	Max	Units
Rx_LOS	LOSS OF SIGNAL	HIGH	LVTTL	2.4	V <sub>CC</sub> +0.3	V
Rx_LOS	NORMAL	LOW	LVTTL	0	0.8	V

I <sup>2</sup> C Serial ID Logic						
Parameter	Function	Logic State	Logic Type	Min	Max	Units
MOD_DEF 0	Digital Ground	Ground	N/A	0	0	V
MOD_DEF 1	Clock Signal	HIGH	LVTTL	2.4	V <sub>CC</sub> +0.3	V
		LOW	LVTTL	0	0.8	V
MOD_DEF 2	Serial Data	HIGH	LVTTL	2.4	V <sub>CC</sub> +0.3	V
		LOW	LVTTL	0	0.8	V

Transmitter Electro-Optical Characteristics						
Parameter	Symbol	LTD1314			Units	Notes
		Min	Typ	Max		
Transmitter Type		1310 nm DFB				
Optical Output Power	P <sub>o</sub>	-2	0	3	dBm	Average Optical Output
Center Wavelength	λ	1270	1310	1355	nm	
Spectral Line Width @ - 20dB	Δλ	-	-	1	nm	
Side Mode Suppression Ratio	SMSR	30			dB	
Extinction Ratio	ER	9	-	-	dB	
Optical Rise and Fall Time	t <sub>r</sub> , t <sub>f</sub>	-	150	260	ps	20% - 80%
Relative Intensity Noise	RIN	-	-	-120	dB/Hz	
Deterministic Jitter	DJ	-	-	0.2	UI	
RMS Jitter	J <sub>RMS</sub>	-	0.03	-	UI	
Output Eye	IEEE 802.3z 1000 BASE-LX Compliant					
Tx Differential Input Impedance	Z <sub>in</sub>	-	100	-	Ohms	
Tx Differential Input Voltage	V <sub>IN</sub>	300	-	2400	mV p-p	LVPECL Tx DATA (Note 1)

Note 1: Internally AC coupled and terminated



**Receiver Electro-Optical Characteristics**

Parameter	Symbol	LTD1314			Units	Notes
		Min	Typ	Max		
Receiver Type		PIN / TIA				
Receiver Optical Sensitivity	$P_{IN}$	-	-	-23	dBm	Average Received Power (Note 1)
Receiver Optical Overload	$P_{INMAX}$	-	-	-3	dBm	
Center Wavelength	$\lambda$	1270	1310	1355	nm	
Optical Return Loss	RL	12	-	-	dB	
Rx Upper 3 dB Cutoff Frequency	$f_c$	-	-	1500	MHz	
Signal Loss - Assert	$P_{SLA}$	-29	-	-25.5	dBm	
Signal Loss - Deassert	$P_{SLD}$	-28.5	-	-25	dBm	
Signal Loss - Hysteresis	$P_H$	0.5	2	5	dB	
Data Output Rise / Fall Time	$t_r / t_f$		150	-	ps	20 - 80 %
Rx Differential Load Impedance	$Z_{LOAD}$	-	100	-	Ohms	
Rx Differential Output Voltage	$V_{OUT}$	400	-	1200	mV p-p	LVPECL Rx DATA (Note 2)
Note 1: Average received power where the BER = $10^{-12}$ , measured with a $2^7-1$ NRZ test pattern						
Note 2: Internally AC coupled and terminated						

**Eye Diagram**

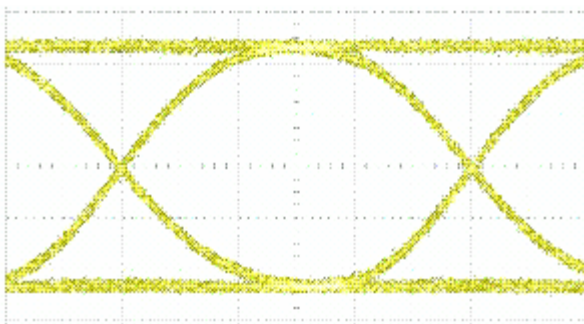

**Transmitter Test Conditions**

- Optical Output Power = **-2 dBm**
- Test Pattern =  $2^7-1$  NRZ PRBS

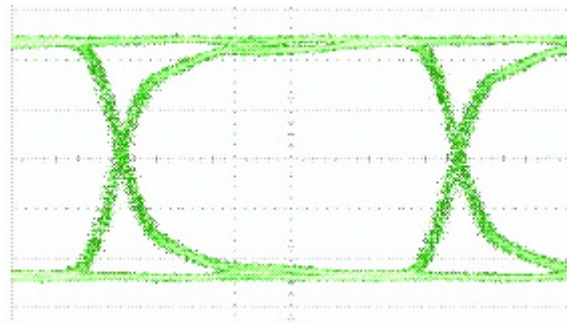

**Receiver Test Conditions**

- Optical Input Power = **-17 dBm**
- Test Pattern =  $2^7-1$  NRZ PRBS

### Transceiver Block Diagram

#### Transmitter Section

The transmitter section consists of a high reliability 1310 nm DFB laser diode (LD) with back facet monitor photo detector (PD) in an eye safe optical sub-assembly (TOSA), which is mated to the Tx port of the fiber optic LC duplex receptacle. A driver IC converts LVPECL differential input data signals into an analog current source that drives the LD. The transmitter is provided with the Tx\_Disable and Tx\_FAULT control and monitoring functions. SFF-8472 Rev 9.3 MSA digital diagnostics are enabled via the 2-wire I<sup>2</sup>C data bus.

#### Receiver Section

The receiver section consists of a high-speed InGaAs PIN photodiode and transimpedance preamplifier mounted in an optical subassembly (ROSA), which is mated to the Rx port of the fiber optic LC duplex receptacle. The output of the PD drives the post-amplification, quantizing, and optical signal detection circuits. The receiver is equipped with the Rx\_LOS (Loss of Signal) monitoring function.

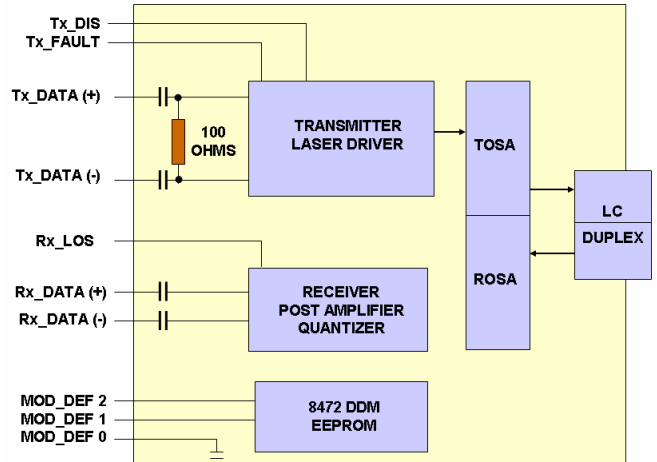

### Transceiver Monitor and Control Functions

#### Rx Signal Loss (Rx\_LOS) Description

The Rx\_LOS (Loss of Signal) is an open collector LVTTTL monitor port. It switches state based on the received optical input signal level that passes through the photo detector (PD), post amplifier and quantizer. If the received signal is above the Rx threshold, then Rx\_LOS is set LOW indicating normal operation. If the received signal is below the Rx threshold, then Rx\_LOS is set HIGH indicating a possible broken fiber, unplugged connector or low Tx signal from the host. The Rx\_LOS pin requires an external 4.7K to 10 K Ohm pull-up resistor.

#### Tx Disable (Tx\_DIS) Description

The Tx\_DIS (Transmit Disable) is an open collector LVTTTL control port that is controlled by a logic signal on the host (system) printed circuit board. If the system is ready to send data then the Tx\_DIS line is set LOW to enable the laser driver and the laser transmitter. If the system is not ready to send data, then the Tx\_DIS line is set HIGH to disable the transmitter.

#### Tx Fault (Tx\_FAULT) Description

The Tx\_FAULT (Transmit Fault) is an open collector LVTTTL monitor port. It switches states based on the condition of the laser driver and the laser including the end of life condition of the laser. If the parameters of the laser driver and laser are within specifications then the Tx\_FAULT is set LOW indicating normal transceiver operation. If a fault occurs, including excess optical output power then Tx\_FAULT is set HIGH which disables the transmitter. The Tx\_FAULT can be reset to normal operation by toggling Tx\_DIS or switching the power supply. The Tx\_FAULT pin requires an external 4.7K to 10K Ohm pull-up resistor.



#### **SFP MSA and SFF 8472 Rev 9.3 Digital Diagnostics**

This device incorporates digital diagnostic monitoring and control functions that are compliant with the SFF-8472 Rev 9.3 Specifications that provides backward compatibility with the digital diagnostic interface defined by the SFP-MSA. The data entry point A0 (hex) is the entry point for the legacy information including Serial ID and Vendor specific information such as the part number, date code, vendor identification, product serial number, type of transceiver and the transceiver parameters. The data entry point A2 (hex) is the entry point for the advanced diagnostic feature sets outlined in the SFF-8472 Rev 9.3 specification. The device is internally calibrated at the time of manufacture and the parameter sets corresponding to the Alarm and Warning functions are programmed into memory. The SFF-8472 Rev 9.3 digital diagnostic interface enables the system host to discover the transceiver's parametric and data functions via a 2-wire system with one wire providing the clock and timing information and the other wire providing two-way communications with the transceiver. Additional information can be found in the SFF-8472 Rev 9.3 documentation.

#### **A0 (hex) Table - Summary of Parameters in the A0 (hex) Parametric Table**

SFP Optical transceiver with LC Duplex connector

Type of transceiver by application

Encoding - 8B10B

The maximum reach of this transceiver over a specified length of fiber type

Vendor Name - Ligent Photonics

Vendor OUI - None

Vendor Part Number - the Ligent Photonics part number on this data sheet

Vendor Revision - the Ligent revision number

Laser Operating Wavelength - the wavelength specified on this data sheet

Options Supported by this Transceiver (LVTTTL digital interface)

Tx\_DISABLE

Tx\_FAULT

Rx\_LOS

Bit Rate MIN and MAX Limits - the limits determined by the Bit Rate tolerances specified on this data sheet

Vendor Serial Number - the Ligent serial number in ASCII format

Diagnostic Monitoring Type - Internally Calibrated

Enhanced Monitoring Features for Software Control are Enabled in this device

Alarm and Warning Flags are enabled

Software support for monitoring and control of Tx\_DISABLE is enabled

Software support for monitoring and control of Tx\_FAULT is enabled

Software support for monitoring and control of Rx\_LOS is enabled

Software support for monitoring and control of RATE\_SELECT is not supported on this device



### A2 (hex) 8472 Digital Diagnostic Table - Summary of Parameters in the A2 (hex) Parametric Table

The data in the parameter tables are compared with the data in the measured data tables in order to create a warning or alarm status bit

Parameters stored in memory are the reference data for this device. There are two tables for each parameter (Warning and Alarm):

Case Temperature	High and Low Values for Alarm and Warning
Operating Voltage	High and Low Values for Alarm and Warning
Laser Bias Current	High and Low Values for Alarm and Warning
Tx Optical Output Power	High and Low Values for Alarm and Warning
Rx Optical Input Power	High and Low Values for Alarm and Warning

The following parameters return the value of zero because this device is internally calibrated

Rx\_PWR(4), Rx\_PWR(3), Rx\_PWR(2), Rx\_PWR(1), Rx\_PWR(0)  
Tx\_I(SLOPE), Tx\_I(OFFSET), Tx\_PWR(SLOPE), Tx\_PWR(OFFSET)  
T(SLOPE), T(OFFSET)  
V(SLOPE, V(OFFSET))

Measured A/D values are stored in two bytes corresponding to the MSB and LSB data

Case Temperature	Signed integer, LSB equal to 1/256C
Operating Voltage	Unsigned integer, LSB equal to 100 $\mu$ Volt
Laser Bias Current	Unsigned integer, LSB equal to 2 $\mu$ A
Tx Optical Output Power	Unsigned integer, LSB equal to 0.1 $\mu$ W
Rx Optical Input Power	Unsigned integer, LSB equal to 0.1 $\mu$ W

Software status bits for software control of this device

Tx_DISABLE	Set or cleared status bit indicates the state of the Tx_DISABLE control function
Tx_DISABLE	Read/Write bit for software control of Tx_DISABLE
Rx_RATE_SELECT	Not used on this device
Tx_FAULT	Set or cleared status bit indicates the state of the Tx_FAULT monitor function
Rx_LOS	Set or cleared status bit indicates the state of the Rx_LOS control function
Data_Ready_Bar	Bit is set at power up and remains set to indicate data is ready to be read
Data_Ready_Bar	Bits is set low when reading data from the transceiver

The Warning or Alarm bit is set when the parameter drops below or exceeds the Low or High values stored in memory. The parametric values are such the Warning bit is set before the Alarm bit:

Case Temperature  
Operating Voltage  
Laser Bias Current  
Tx Optical Output Power  
Rx Optical Input Power



SFF-8472 Rev 9.3 A2 (HEX) Address Table for Alarm and Warning Data														
8472 Parameter	Alarm Threshold Data				Warning Threshold Data				Internally Measured Values		Alarm Bit (Set) Address + Position		Warning Bit (Set) Address + Position	
	High Value		Low Value		High Value		Low Value				High	Low	High	Low
	MSB	LSB	MSB	LSB	MSB	LSB	MSB	LSB	MSB	LSB	High	Low	High	Low
Temperature	00	01	02	03	04	05	06	07	96	97	112(7)	112(6)	116(7)	116(6)
Vcc	08	09	10	11	12	13	14	15	98	99	112(5)	112(4)	116(5)	116(4)
Tx Bias	16	17	18	19	20	21	22	23	100	101	112(3)	112(2)	116(3)	116(2)
Tx Out	24	25	26	27	28	29	30	31	102	103	112(1)	112(0)	116(1)	116(0)
Rx Input	32	33	34	35	36	37	38	39	104	105	113(7)	113(8)	117(7)	117(6)

**Electrical Interface**

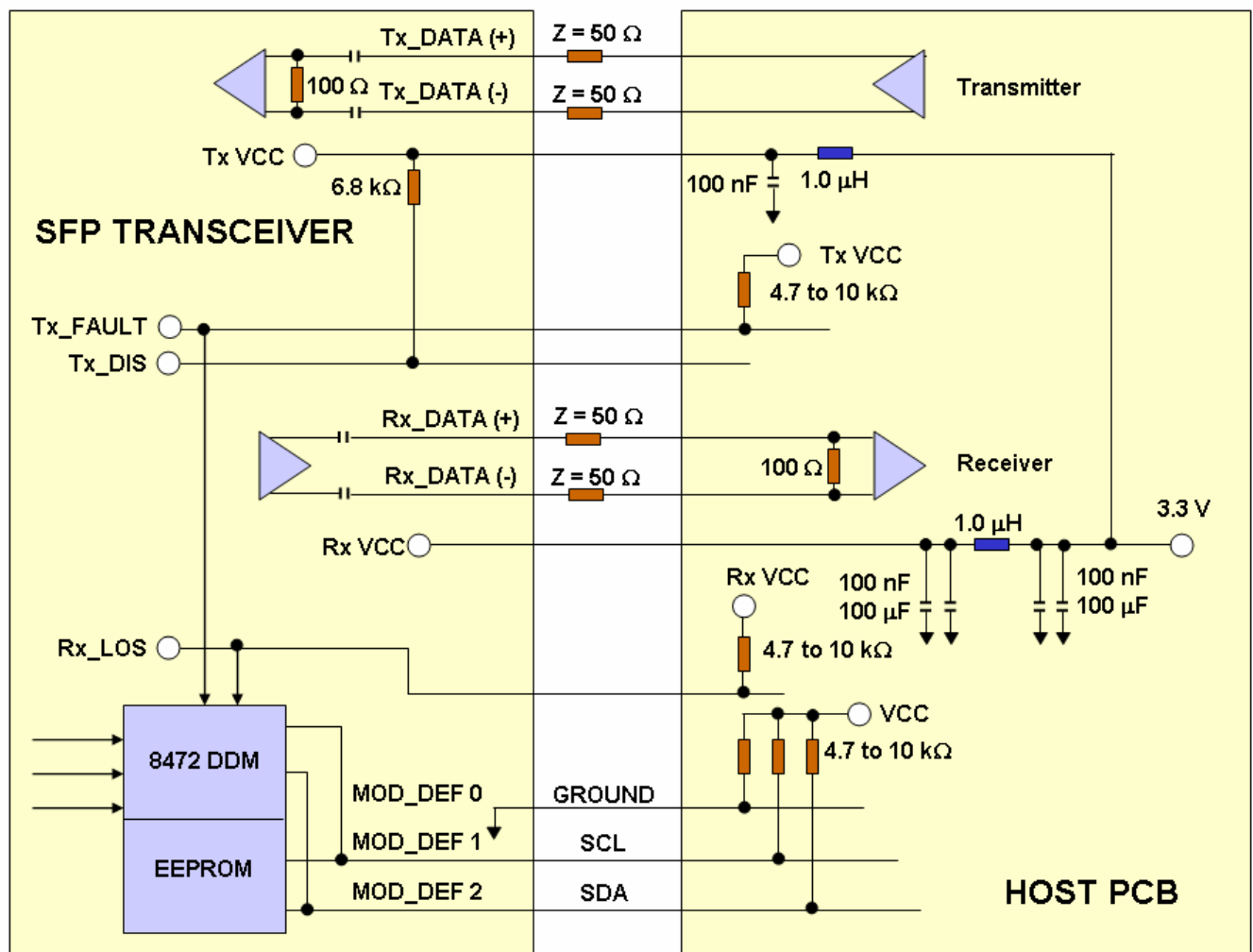



**Pin Assignment**

20	VEET
19	TD-
18	TD+
17	VEET
16	VCCT
15	VCCR
14	VEER
13	RD+
12	RD-
11	VEER

1	VEET
2	Tx_FAULT
3	Tx_DIS
4	MOD_DEF 2
5	MOD_DEF 1
6	MOD_DEF 0
7	Rate Select
8	Rx_LOS
9	VEER
10	VEER

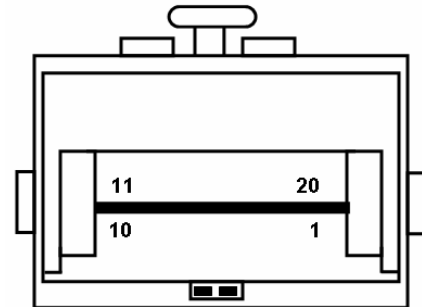

Transceiver Pin Locations

**SFP Pin Assignment**

Pin	Symbol	Logic Type	Description	Notes
1	V <sub>EET</sub>	N/A	Transmitter Ground	
2	Tx_FAULT	LVTTTL	Transmitter Fault, LOW = Normal Operation, HIGH = Fault Indication	Note 1
3	Tx_DIS	LVTTTL	Transmit Disable, LOW = Normal Operation, HIGH = Disables Module	Note 1
4	MOD_DEF 2	LVTTTL	Module Definition 2 - Two-Wire Interface - Serial Data	Note 1
5	MOD_DEF 1	LVTTTL	Module Definition 1 - Two-Wire Interface - Clock Signal	Note 1
6	MOD_DEF 0	LVTTTL	Module Definition 0 - Two-Wire Interface Digital Ground	
7	Rate Select	N/A	Not Connected	
8	Rx_LOS	LVTTTL	Receiver Loss of Signal, LOW = Normal Operation, HIGH = Loss of Signal	Note 1
9	V <sub>EER</sub>	N/A	Receiver Ground	
10	V <sub>EER</sub>	N/A	Receiver Ground	
11	V <sub>EER</sub>	N/A	Receiver Ground	
12	RD-	LVPECL	Rx_Data Output (Inverted)	Note 2
13	RD+	LCPECL	Rx_Data Output (Non Inverted)	Note 2
14	V <sub>EER</sub>	N/A	Receiver Ground	
15	V <sub>CCR</sub>	N/A	Receiver DC Power	3.3 V +/- 5%
16	V <sub>CCT</sub>	N/A	Transmitter DC Power	3.3 V +/- 5%
17	V <sub>EET</sub>	N/A	Transmitter Ground	
18	TD+	LVPECL	Tx_Data Input (Non Inverted)	Note 3
19	TD-	LVPECL	Tx_Data Input (Inverted)	Note 3
20	V <sub>EET</sub>	N/A	Transmitter Ground	

**Notes**

1	The uncommitted Tx_Fault, Rx_LOS, MOD_DEF 1 and MOD_DEF 2 LVTTTL monitor and control pins each require a pull up resistor of 4.7K to 10K Ohms.
2	The 100 Ohm differential Rx Data output is internally AC coupled and must be terminated with 100 Ohms at the differential user interface.
3	The 100 Ohm differential Tx Data input is internally AC coupled and terminated.



**Recommended PCB Layout**

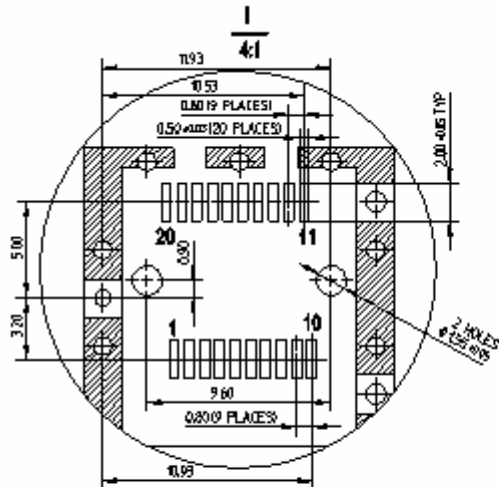

- Notes:**
1. Datum and basic dimensions established by customer
  2. Pads and vias are chassis ground, 11 places
  3. Thru holes, plating optional

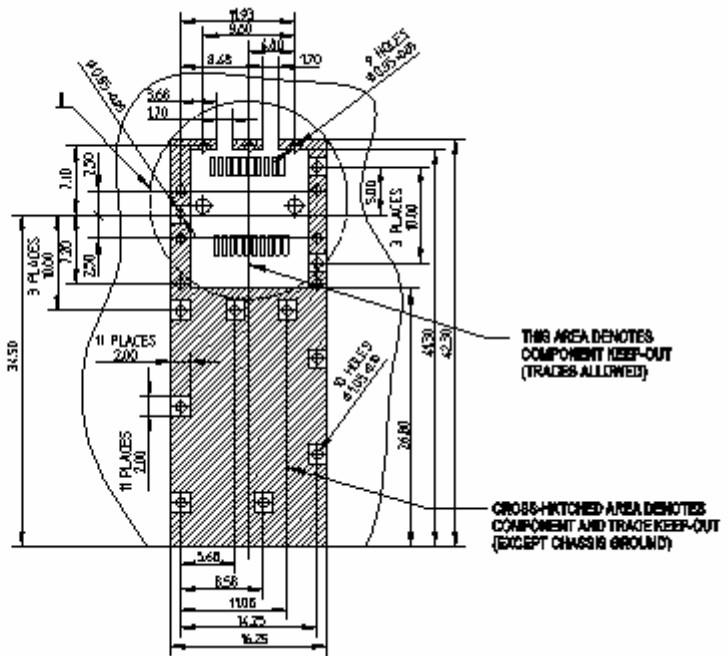

**Recommended Front Panel Layout Opening for LC**

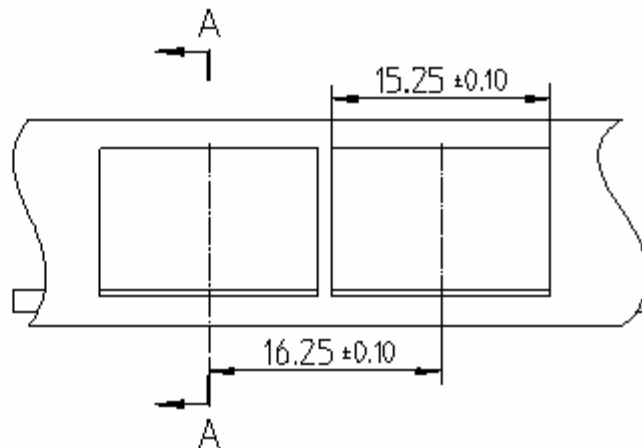
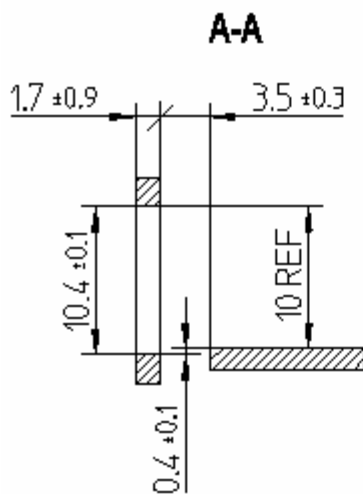



#### Mechanical Dimensions

Bail Latch

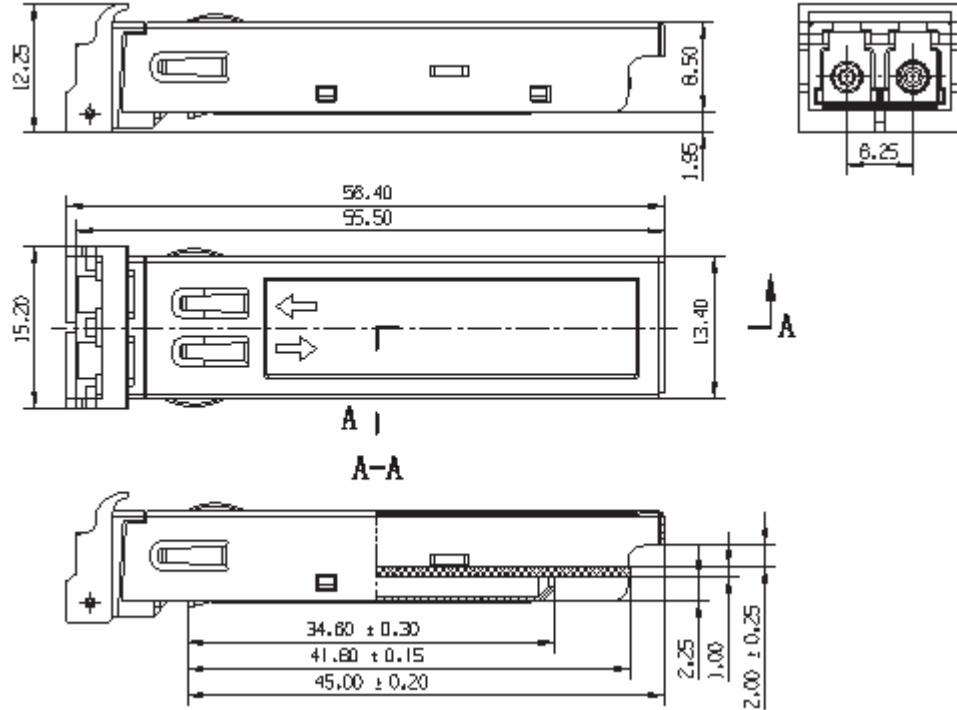

Pull Latch

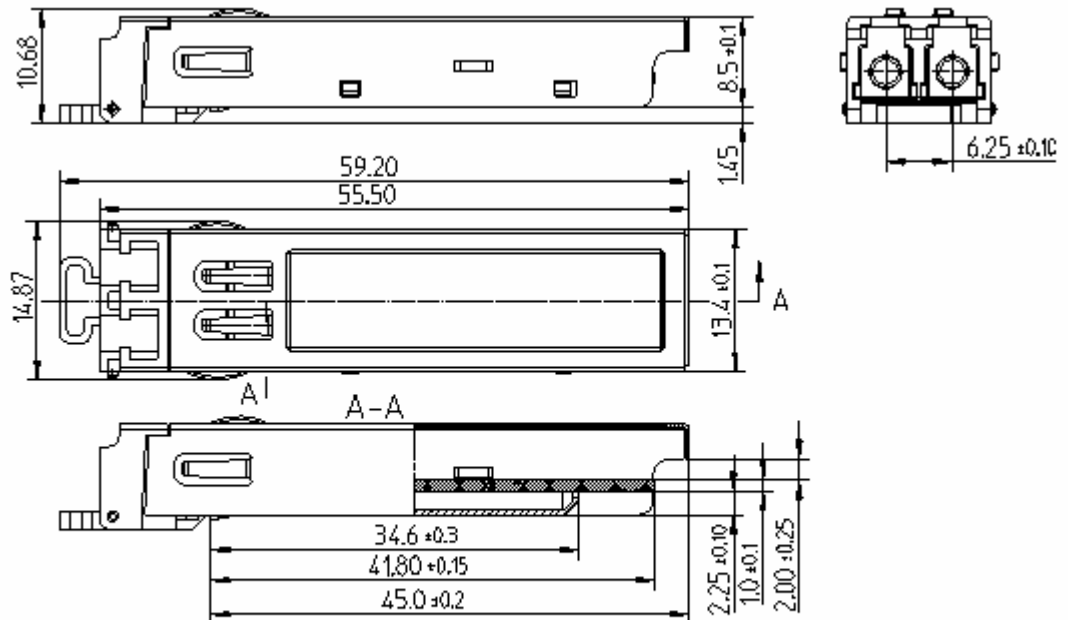

Dimensions are in millimeters  
Dimension tolerance is ± 0.1mm unless otherwise specified

### Regulatory Information

#### Eye Safety

The transceiver is a Class 1 eye-safe device according to FDA 21CFR1040.10 and IEC 60825-1.

#### Electromagnetic Interference (EMI), Immunity and Product Safety

The transceiver is ESD safe (electrical pins) when tested according to MIL-STD-883, Method 3015.7 and ESD safe (optical connector) when tested according to IEC 61000-4-2. The device is immune to strong RF fields when tested in accordance with IEC 61000-4-3. The device complies with (US) FCC, Part 15, Subpart J; (Europe) CENELEC EN 55022; (Canada) Class B (CISPR22A); and (Japan) VCCI Class 1. The device has been designed to conform to product safety requirements including UL1950, CSA 22.2, and IEC 60950-1, and has been designed to meet the flammability requirements of UL94.

#### Notice

The factory has made all adjustments to this device prior to shipment. No adjustments or modifications to the device are required or permitted. Any adjustment, modification or tampering of the device voids the product warranty. The US Food and Drug Administration may consider that any adjustment or modification to this device is an act of manufacturing and therefore will require that the device be recertified in accordance with 21 CFR 1040.10 Subpart j.

#### Laser Radiation Information

Wavelength	1310 nm
FDA Total Pout: 7 mm aperture at 20 cm distance	< 195 microwatts
IEC Total Pout : 7 mm aperture at 10 cm distance	< 15, 600microwatts
Beam Divergence	17.25°

#### Required Label

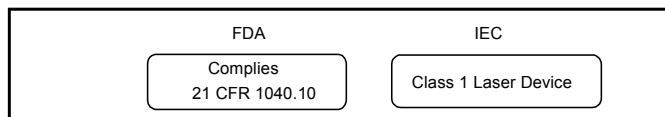

#### Laser Emission

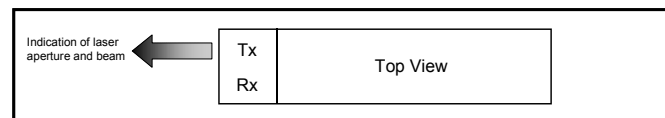

### Ligent Sales Offices - USA

#### Ligent Photonics, Inc.

2701 Dukane Drive  
Suite 200  
St. Charles, IL 60174  
PH (630) 513-7226  
FX (630) 513-9173  
WS www.ligentphotonics.com

#### Ligent Photonics, Inc.

(Virginia Sales Office)  
8210 Strathmore Lane  
Roanoke, VA 24019  
PH (540) 797-5793  
FX (540) 366-5793  
WS www.ligentphotonics.com

#### New Age Electronics

3000 Northwood's Parkway  
Suite 280  
Norcross, GA 30071  
PH (770) 242-8800  
FX (770) 242-8180  
WS www.newagelec.com

#### New Age Electronics

8376 Six Forks Road  
Suite 202  
Raleigh, NC 27615  
PH (919) 866-0620  
FX (919) 866-0621  
WS www.newagelec.com

#### New Age Electronics

4940 Corporate Drive  
Suite B  
Huntsville, AL 35805  
PH (256) 430-8000  
FX (256) 430-8414  
WS www.newagelec.co

#### K-Tech Sales

100 Century Center Court  
Suite 405  
San Jose, CA 95112  
PH (408) 437-1808  
FX (408) 437-1883  
WS www.ktechsales.com

#### Kruvand Associates

1202 Richardson Drive  
Suite 113  
Richardson, TX 75080  
PH (972) 437-3355  
FX (972) 680-8854  
WS www.kruvand.com

#### Kruvand Associates

8100 Shoal Creek Boulevard  
Suite 250  
Austin, TX 75080  
PH (512) 454-1111  
FX (512) 454-9858  
WS www.kruvand.com

#### Kruvand Associates

10601 Grant Road  
Suite 104  
Houston, TX 77070  
PH (713) 956-6741  
FX (713) 972-680-8854  
WS www.kruvand.com

#### VAL Technical Sales

183 Prospect Street  
Hingham, MA 02043  
PH (781) (781) 749-8358  
FX (781) 740-4663  
WS www.valtechnical.com

### Ligent Sales Offices - Asia

#### Hisense Optoelectronics Technology Co., Limited

No.11, Jiangxi Road  
Qingdao, Shandong  
China 266071  
PH 86 (532) 601-0000  
FX 86 (532) 601-6007  
WS www.hisenseopto.com

#### Summit Hisense Company, Limited

Triton Square  
Office Tower Z 19F 1-8-12  
Harumi Chuo-ku 104-6219  
Japan  
PH 81-3-5547-1252  
FX 81-3-5547-1268