



LTC1519 SFF Optical Transceiver Gigabit Ethernet, 1550 nm, 1250 Mb/s, 80 km

Product Description

The LTC1519 SFF Gigabit-Ethernet LC duplex transceiver is intended for 80 km reach service in 1250 Mb/s 1550 nm single mode high-speed LAN and SAN data communications equipment where low-cost, extraordinary performance and reliability is essential. It meets the requirements of IEEE802.3z 1000 BASE-LH, consumes low power, operates from a 3.3 volt DC power supply and is offered in the 0 to 70°C commercial temperature range. The industry standard 2x5 small form factor (SFF) package is fabricated with a rugged die cast metal housing and cage assembly. The low jitter and low bit error rate optical assembly features a 1550 nm DFB laser transmitter and PIN/TIA receiver. It incorporates the SFF MSA LVTTTL Rx_Signal Detect (Rx_SD) and Tx Disable (Tx_DIS) monitor and control functions. The differential AC coupled Tx and Rx data interfaces (50 ohms to ground, 100 ohms line to line) are LVPECL compatible. The device is Class I laser safety compliant.



Applications

- 1250 Mb/s Gigabit Ethernet data links
- Channel extenders
- Bus extenders
- High speed I/O file servers
- Data storage networks
- LAN
- SAN
- RSAN
- Host adapters
- Switch-to-switch interfaces
- Mass storage system interconnects
- Hub interconnects
- Router interconnects
- Distributed multi processing
- Telecom switches

Features

- LC Duplex optical interface
- 80 km reach
- 1250 Mb/s data rate
- +3.3 V power supply
- Low DC power consumption
- 2x5 SFF MSA compliant package
- High performance 1550 nm DFB laser
- High sensitivity PIN/TIA optical receiver:
- Single Mode operation
- BER < 1X10⁻¹²
(2⁷ - 1 NRZ PRBS test pattern)
- IEEE 802.3z 1000 BASE-LH compliant
- Operating temperature range:
 - Commercial: 0 to 70°C
- Monitor and Control Functions
 - Signal Detect (Rx_SD), LVTTTL
 - Tx Disable (Tx_DIS), LVTTTL
- Internally AC coupled and terminated
- LVPECL Rx and Tx data interface
 - 100 Ohms differential (line to line)
 - 50 Ohms single ended (line to ground)



Absolute Maximum Ratings				
Parameter	Symbol	Minimum	Maximum	Units
Storage Temperature	T_{stg}	-40	+85	°C
Relative Humidity - Storage	RH_S	0	95	%
Relative Humidity - Operating	RH_O	0	85	%
DC Supply Voltage	V_{CC}	0	3.6	V
Soldering Temperature	T_{slid}	0	260	°C
Soldering Time Duration	t_{slid}	0	10	seconds
Optical and Electrical Signal Absolute Maximum Ratings				
Signal / Data Input Voltage (Tx_DATA)	$V_{IN\ PK-PK}$	0.3	2.4	V pk-pk
Rx Optical Input Power	P_{IN-MAX}	-	-3	dBm
Logic State Absolute Maximum Ratings				
Tx_DISABLE Logic HIGH State	Tx_DIS	-	$V_{CC} + 0.5$	V
Rx_SD Logic HIGH State	Rx_SD	-	$V_{CC} + 0.5$	V

Recommended Operating Conditions						
Parameter	Symbol	Min	Typ	Max	Units	Notes
Ambient Operating Temperature	T_{amb}	0	25	+70	°C	Temperature Range = C
DC Supply Voltage	V_{CC}	3.14	3.30	3.46	Volts	
Module Supply Current	I_{IN}	-	150	200	mA	
Power Dissipation	P_D		500	700	mW	



LTC1519 SFF Optical Transceiver

Gigabit Ethernet, 1550 nm, 1250 Mb/s, 80 km

Transmitter Logic							
Parameter	Function	Logic State	Logic Type	Min	Max	Units	Notes
Tx DIS	DISABLE	HIGH	LVTTTL	2.4	3.3	V	
Tx DIS	ENABLE	LOW	LVTTTL	0	0.8	V	

Receiver Logic							
Parameter	Function	Logic State	Logic Type	Min	Max	Units	Notes
Rx_SD	SIGNAL DETECT	HIGH	LVTTTL	2.4	3.3	V	
Rx_SD	NORMAL	LOW	LVTTTL	0	0.8	V	

Transmitter Electro-Optical Characteristics						
Parameter	Symbol	LTC1519			Units	Notes
		Min	Typ	Max		
Transmitter Type		1550 nm DFB				
Optical Output Power	P_o	0		4	dBm	Average Optical Output
Optical Modulation Amplitude	OMA	196	-	-	μ W	
Center Wavelength	λ		1550		nm	
Spectral Line Width @ -20dB	$\Delta\lambda$	-	-	1	nm	
Side Mode Suppression Ratio	SMSR	30	-	-	dB	
Extinction Ratio	ER	9	-	-	dB	
Optical Rise and Fall Time	t_r, t_f	-	150	260	ps	20% - 80%
Relative Intensity Noise	RIN	-	-	-120	dB/Hz	
Deterministic Jitter	DJ	-	-	0.2	UI	
RMS Jitter	J_{RMS}	-	-	0.01	UI	
Output Eye		IEEE 802.3z 1000 BASE-LH compliant				
Tx Differential Input Impedance	Z_{in}	-	100	-	Ohms	
Tx Differential Input Voltage	V_{IN}	300	-	2400	mV p-p	LVPECL Tx DATA (Note 1)

Note 1: Internally AC coupled and terminated



Receiver Electro-Optical Characteristics						
Parameter	Symbol	LTC1519			Units	Notes
		Min	Typ	Max		
Receiver Type		PIN / TIA				
Receiver Optical Sensitivity	P_{IN}	-	-	-24	dBm	Average Received Power (Note 1)
Receiver Optical Overload	$P_{IN\ MAX}$	-	-	0	dBm	
Center Wavelength	λ		1550		nm	
Optical Return Loss	RL	12	-	-	dB	
Rx Upper 3 dB Cutoff Frequency	f_c	-	-	1500	MHz	
Signal Detect - Assert	P_{SDA}	-32	-	-24.5	dBm	
Signal Detect - Deassert	P_{SDD}	-32.5	-	-25	dBm	
Signal Detect - Hysteresis	P_H	0.5	2	5	dB	
Data Output Rise / Fall Time	t_r / t_f		150	-	ps	20 - 80 %
Rx Differential Load Impedance	Z_{LOAD}	-	100	-	Ohms	
Rx Differential Output Voltage	V_{OUT}	400	-	1200	mV p-p	LVPECL Rx DATA (Note 2)
Note 1: Average received power where the BER = 10^{-12} , measured with a 2^7-1 NRZ test pattern						
Note 2: Internally AC coupled and terminated						

Eye Diagram

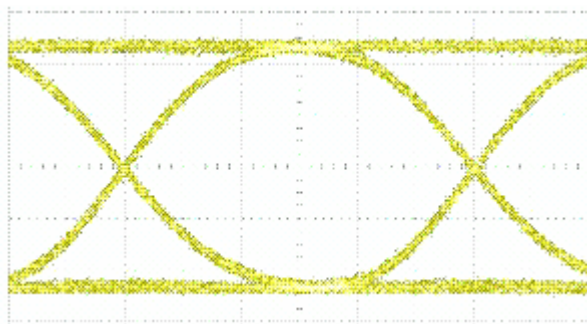

Transmitter Test Conditions

- Optical Output Power = **0 dBm**
- Test Pattern = 2^7-1 NRZ PRBS

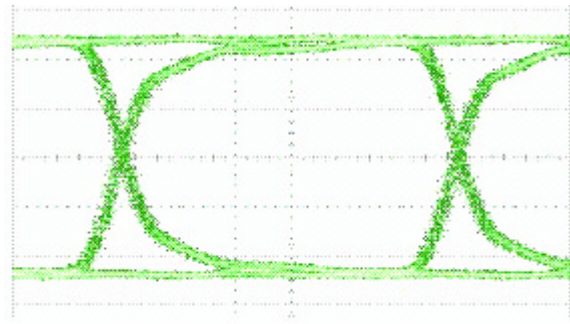

Receiver Test Conditions

- Optical Input Power = **-17 dBm**
- Test Pattern = 2^7-1 NRZ PRBS

Transceiver Block Diagram

Transmitter Section

The transmitter section consists of a high reliability 1550 nm DFB laser diode (LD) with back facet monitor photo detector (PD) in an eye safe optical sub-assembly (TOSA), which is mated to the Tx port of the fiber optic LC duplex receptacle. A driver IC converts LVPECL differential input data signals into an analog current source that drives the LD. The transmitter is provided with the Tx_Disable control function.

Receiver Section

The receiver section consists of a high-speed PIN / TIA photodiode (PD) and transimpedance preamplifier mounted in an optical subassembly (ROSA), which is mated to the Rx port of the fiber optic LC duplex receptacle. The output of the PD drives the post-amplification, quantizing, and optical signal detection circuits. The receiver is equipped with the Rx_SD (Signal Detect) monitoring function.

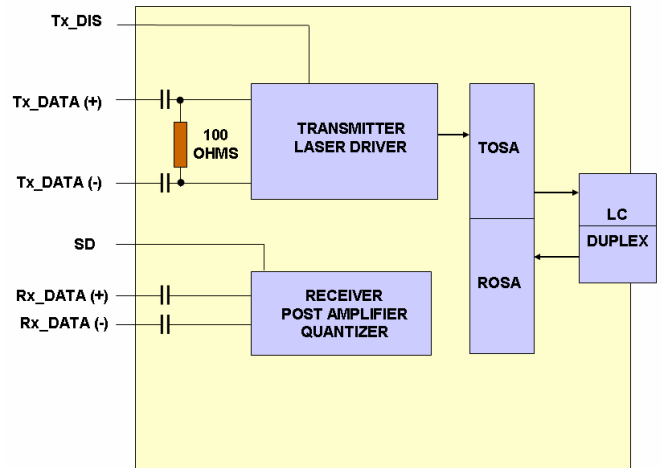

Transceiver Monitor and Control Functions

Rx Signal Detect (SD) Description

The Rx_SD (Signal Detect) is an LVTTTL monitor port. It switches state based on the received optical input signal level that passes through the photo detector (PD), post amplifier and quantizer. If the received signal is above the Rx threshold, then Rx_SD is set HIGH indicating normal operation. If the received signal is below the Rx threshold, then Rx_SD is set LOW indicating a possible broken fiber, unplugged connector or no Tx signal from the host.

Tx Disable (Tx_DIS) Description

The Tx_DIS (Transmit Disable) is an LVTTTL control port that is controlled by a logic signal on the host (system) printed circuit board. If the system is ready to send data then the Tx_DIS line is set LOW to enable the laser driver and the laser transmitter. If the system is not ready to send data, then the Tx_DIS line is set HIGH to disable the transmitter.



SFF PIN ASSIGNMENT

Pin	Symbol	Description
1	V _{EER}	Receiver Signal Ground
2	V _{CCR}	+3.3 Volt Receiver Power Supply
3	SD	Signal Detect, LVTTTL, LOW= No Signal, HIGH = Normal
4	RD-	Rx Data - Inverted Differential Output
5	RD+	Rx Data - Non Inverted Differential Output
6	V _{CCT}	+3.3 Volt Transmitter Power Supply
7	V _{EET}	Transmitter Signal Ground
8	Tx_DIS	Transmit Disable, LVTTTL, LOW = Normal, HIGH = Transmitter Disabled
9	TD+	Tx Data - Non Inverted Differential Input
10	TD-	Tx Data - Inverted Differential Input
Mounting Posts		The mounting posts are provided for mechanically attaching the transceiver to the circuit board. They should not be connected to the circuit ground but can be connected to the chassis ground.
Housing Leads		The housing leads should be connected to circuit ground

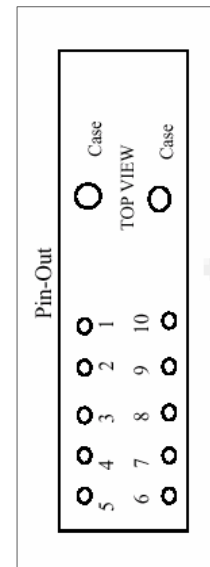

Transceiver Pin Locations

Notes

1. The uncommitted SD and Tx_DIS LVTTTL monitor and control pins each require a pull up resistor of 4.7K to 10K Ohms.
2. The 100 Ohm differential Rx Data output is internally AC coupled and must be terminated with 100 Ohms at the differential user interface.
3. The 100 Ohm differential Tx Data input is internally AC coupled and terminated.

Electrical Interface

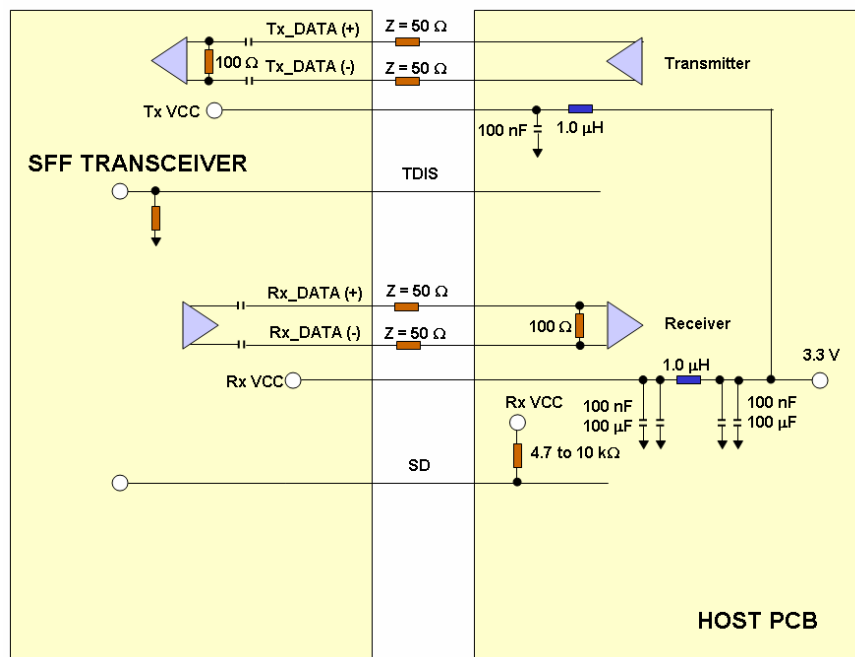



Mechanical Specifications

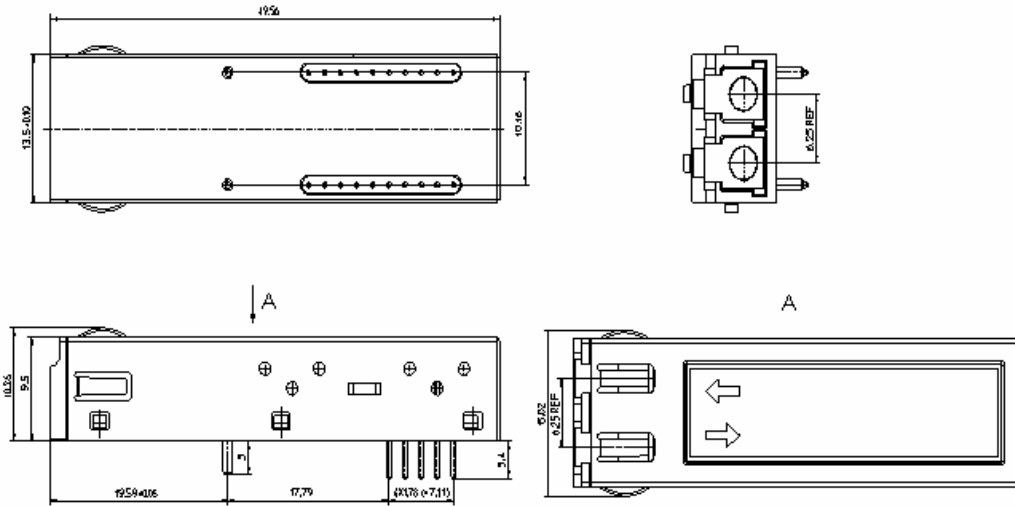

Dimensions are in millimeters
Dimension tolerance is ± 0.1 mm unless otherwise specified

Circuit Board Layout (MSA)

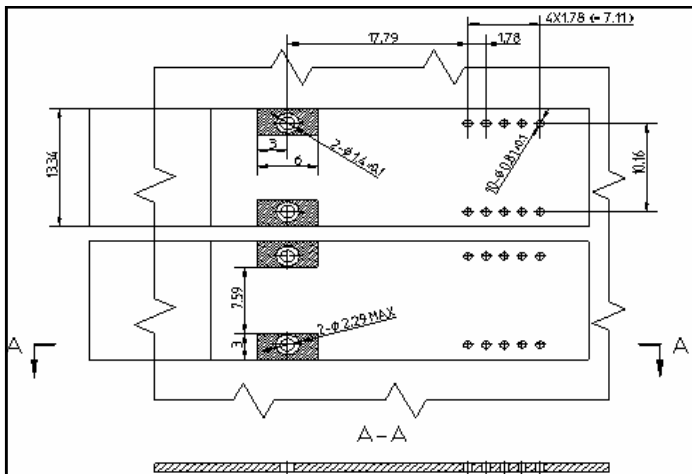

Front Panel Layout (MSA)

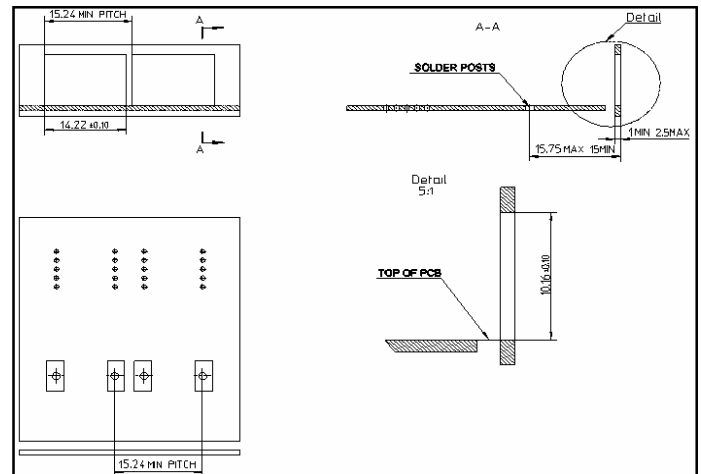



LTC1519 SFF Optical Transceiver Gigabit Ethernet, 1550 nm, 1250 Mb/s, 80 km

Regulatory Information

Eye Safety

The transceiver is a Class 1 eye-safe device according to FDA 21CFR1040.10 and IEC 60825-1.

Electromagnetic Interference (EMI), Immunity and Product Safety

The transceiver is ESD safe (electrical pins) when tested according to MIL-STD-883, Method 3015.7 and ESD safe (optical connector) when tested according to IEC 61000-4-2. The device is immune to strong RF fields when tested in accordance with IEC 61000-4-3. The device complies with (US) FCC, Part 15, Subpart J; (Europe) CENELEC EN 55022; (Canada) Class B (CISPR22A); and (Japan) VCCI Class 1. The device has been designed to conform to product safety requirements including UL1950, CSA 22.2, and IEC 60950-1, and has been designed to meet the flammability requirements of UL94.

Notice

The factory has made all adjustments to this device prior to shipment. No adjustments or modifications to the device are required or permitted. Any adjustment, modification or tampering of the device voids the product warranty. The US Food and Drug Administration may consider that any adjustment or modification to this device is an act of manufacturing and therefore will require that the device be recertified in accordance with 21 CFR 1040.10 Subpart j.

Laser Radiation Information

Wavelength	1550 nm
FDA Total Pout: 7 mm aperture at 20 cm distance	< 790 microwatts
IEC Total Pout : 7 mm aperture at 10 cm distance	< 10,000 microwatts
Beam Divergence	17.25°

Required Label

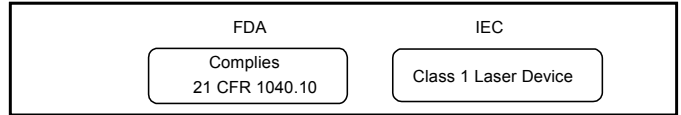

Laser Emission

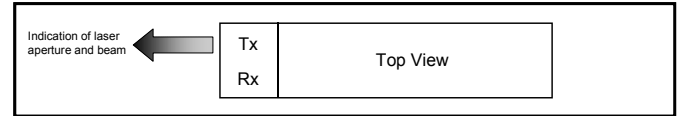

Ligent Sales Offices - USA

Ligent Photonics, Inc.

2701 Dukane Drive
Suite 200
St. Charles, IL 60174
PH (630) 513-7226
FX (630) 513-9173
WS www.ligentphotonics.com

Ligent Photonics, Inc.

(Virginia Sales Office)
8210 Strathmore Lane
Roanoke, VA 24019
PH (540) 797-5793
FX (540) 366-5793
WS www.ligentphotonics.com

New Age Electronics

3000 Northwood's Parkway
Suite 280
Norcross, GA 30071
PH (770) 242-8800
FX (770) 242-8180
WS www.newagelec.com

New Age Electronics

8376 Six Forks Road
Suite 202
Raleigh, NC 27615
PH (919) 866-0620
FX (919) 866-0621
WS www.newagelec.com

New Age Electronics

4940 Corporate Drive
Suite B
Huntsville, AL 35805
PH (256) 430-8000
FX (256) 430-8414
WS www.newagelec.com

K-Tech Sales

100 Century Center Court
Suite 405
San Jose, CA 95112
PH (408) 437-1808
FX (408) 437-1883
WS www.ktechsales.com

Kruvand Associates

1202 Richardson Drive
Suite 113
Richardson, TX 75080
PH (972) 437-3355
FX (972) 680-8854
WS www.kruvand.com

Kruvand Associates

8100 Shoal Creek Boulevard
Suite 250
Austin, TX 75080
PH (512) 454-1111
FX (512) 454-9858
WS www.kruvand.com

Kruvand Associates

10601 Grant Road
Suite 104
Houston, TX 77070
PH (713) 956-6741
FX (713) 972-680-8854
WS www.kruvand.com

VAL Technical Sales

183 Prospect Street
Hingham, MA 02043
PH (781) (781) 749-8358
FX (781) 740-4663
WS www.valtechnical.com

Ligent Sales Offices - Asia

Hisense Optoelectronics Technology Co., Limited

No.11, Jiangxi Road
Qingdao, Shandong
China 266071
PH 86 (532) 601-0000
FX 86 (532) 601-6007
WS www.hisenseopto.com

Summit Hisense Company, Limited

Triton Square
Office Tower Z 19F 1-8-12
Harumi Chuo-ku 104-6219
Japan
PH 81-3-5547-1252
FX 81-3-5547-1268